











# *User's Manual*































































































**GB**









































































## *Network recorder - MC750 TH*







































# TABLE OF CONTENTS

<b>NETWORK RECORDER - MC750 TH</b> .....	<b>1</b>
<b>WARNINGS, INFORMATION AND NOTES REGARDING DESIGNATION OF THE PRODUCT</b> .....	<b>2</b>
<b>BEFORE SWITCHING THE DEVICE ON</b> .....	<b>3</b>
<b>DEVICE SWITCH OFF WARNING</b> .....	<b>4</b>
<b>HEALTH AND SAFETY</b> .....	<b>5</b>
<b>REAL TIME CLOCK</b> .....	<b>6</b>
<b>DISPOSAL</b> .....	<b>7</b>
<b>BASIC DESCRIPTION AND OPERATION</b> .....	<b>8</b>
GLOSSARY .....	8
DESCRIPTION OF THE PRODUCT .....	9
<i>Appearance</i> .....	9
PURPOSE AND USE OF MC750 TH NETWORK RECORDER .....	9
<i>Network recorder</i> .....	9
<i>Supported measurements</i> .....	10
<b>CONNECTION</b> .....	<b>11</b>
INTRODUCTION .....	11
MOUNTING .....	12
ELECTRIC CONNECTION .....	13
CONNECTION OF INPUT/OUTPUT MODULES .....	14
COMMUNICATION CONNECTION .....	16
<i>RS232</i> .....	16
<i>RS485</i> .....	16
<i>Ethernet</i> .....	17
<i>USB</i> .....	17
<i>Survey of communication connection</i> .....	17
<i>Survey of communication connection for Analogue extender EX104</i> .....	18
CONNECTION OF POWER SUPPLY .....	18
<b>FIRST STEPS</b> .....	<b>19</b>
INTRODUCTION .....	19
<i>Basic concepts</i>  .....	19
<i>Installation wizard</i>  .....	20
DISPLAY OF DEVICE INFO .....	21
<i>Welcome screen</i>  .....	21
<i>Information</i>   .....	21
<i>Memory</i>   .....	22
<i>Time, date and temperature</i>   .....	22
<i>Meaning of icons</i>  .....	22
<b>SETTINGS</b> .....	<b>23</b>
INTRODUCTION .....	23
MIQEN SOFTWARE .....	23
<i>Devices management</i> .....	23
<i>Device settings</i> .....	23

Real-time measurements .....	23
Data analysis.....	23
Software upgrading .....	23
SETTING PROCEDURE .....	24
GENERAL SETTINGS.....	24
Description and Location  	24
Average interval   	24
Language   	25
Currency   	25
Temperature unit   	25
Date format   	25
Date and time  	25
Time Synchronisation source  	25
Time zone  	25
Auto Summer/Winter time  	25
Maximum demand calculation (MD mode)   	26
Resetting Min/Max   	28
Starting current for PF and PA (mA)  	28
Starting current for all powers (mA)  	28
Calculation of harmonics  	28
Reactive power and energy calculation 	28
CONNECTION .....	29
Connection   	29
Setting of current and voltage ratios   	29
Used voltage and current range  	29
Nominal frequency  	29
Wrong connection warning 	29
Energy flow direction 	29
CT connection 	29
SERIAL COMMUNICATION.....	30
Serial Communication (COM1)   	30
2nd Communication module (COM2)  	30
USB COMMUNICATION .....	30
USB Communication 	30
ETHERNET COMMUNICATION.....	31
Ethernet communication  	31
DISPLAY .....	32
Display settings   	32
Demo cycling period   	32
Settings of customized screens   	32
SECURITY.....	33
Password setting  	34
Password modification  	34
Password disabling  	34
Password and language .....	34
ENERGY - COUNTERS.....	35
Active tariff   	35
Common Energy Counter Resolution  	35
Common energy cost exponent  	35
Common tariff price exponent  	35
LED Energy Counter  	36
LED Number of pulses  	36
LED Pulse length (ms)  	36
Counters - Measured Energy  	36
Counters - Individual counter Resolution  	36
Counters – Tariff Selector.....	36
Tariff clock  	36
INPUTS AND OUTPUTS .....	38

Analogue input module  	38
Pulse input module 	39
Digital input module 	39
Tariff input module  	39
Analogue output module  	39
Pulse output module   	40
Alarm output module (Relay output module)   	40
Watchdog and Relay output module  	40
Bistable alarm output module  	40
Functions of Digital output (Pulse and Relay) modules   	40
2nd Communication module (COM2)   	41
Communication module for Analogue extender EX104   	41
<b>ALARMS</b>	42
Alarms setting  	42
Types of alarms	43
Alarms PUSH functionality	43
<b>MEMORY</b>	43
Memory division  	43
Memory operation	44
Memory clearing  	44
Recorders A, B, C and D setting 	44
<b>RESET OPERATIONS</b>	45
Reset Min / Max values  	45
Reset energy counters (E1, E2, E3, E4)  	45
Reset energy counters costs (E1, E2, E3, E4)  	45
Reset maximal MD values  	45
Reset the last MD period  	45
MD synchronization  	46
Alarm relay (1 or 2) Off  	46
Reset Min / Max values  	46
Reset alarm statistic 	46
<b>SETTINGS AND MEMORY CARD</b>	46
Supported memory cards	46
Directory structure on memory card	46
Handling memory card	48
Memory card information  	48
Save data  	48
Save settings  	48
Load settings  	49
Firmware upgrading  	49
<b>MEASUREMENTS</b>	50
INTRODUCTION	50
AVAILABLE CONNECTIONS	50
<i>Survey of supported measurements regarding connection mode</i>	50
EXPLANATION OF BASIC CONCEPTS	53
<i>Sample factor – MV</i>	53
<i>Average interval – MP</i>	53
<i>Power and energy flow</i>	54
CALCULATION AND DISPLAY OF MEASUREMENTS	55
<i>Keyboard and display presentation</i>	55
PRESENT VALUES	55
Voltage  	55
Current  	56
Active, reactive and apparent power  	56
Power factor and power angle  	56
Frequency  	56
Energy - counters  	57

MD values  	57
THD - Total harmonic distortion  	57
Flickers  	57
Customized screens  	57
Overview  	57
MIN/MAX VALUES .....	59
Phase voltage Min/Max  	59
Current Min/Max  	59
Active power Min/Max  	59
Apparent power Min/Max  	59
Frequency Min/Max  	59
Date and time of reset Min/Max  	59
ALARMS .....	60
SURVEY OF ALARMS  	60
TIME GRAPHICAL DISPLAY (GRAPHS TIME) .....	60
Phase voltage  	60
Phase-to-phase voltage  	60
Current  	60
FFT GRAPHICAL DISPLAY (GRAPHS FFT) .....	61
Phase voltage  	61
Phase-to-phase voltage  	61
Current  	61
Demo cycling 	61
<b>COMMUNICATION MODES .....</b>	<b>62</b>
PULL COMMUNICATION MODE .....	62
PUSH COMMUNICATION MODE .....	62
Explanation .....	62
Protocol and data format .....	62
Data transmission .....	63
Supported quantities and settings .....	63
<b>TECHNICAL DATA .....</b>	<b>64</b>
ACCURACY .....	64
INPUTS .....	65
CONNECTION .....	65
MODULES .....	66
COMMUNICATION .....	68
ELECTRONIC FEATURES .....	68
SAFETY FEATURES .....	69
DIMENSIONS .....	69
<b>APPENDIX A: MODBUS PROTOCOL .....</b>	<b>71</b>
MODBUS COMMUNICATION PROTOCOL .....	71
Modbus .....	71
Register table for the actual measurements .....	71
Register table for the normalized actual measurements (IEEE 754) Floating-Point Single Precision Value (32 bit) .....	73
Register table for the normalized actual measurements .....	75
100% values calculations for normalized measurements .....	76
Register table for the basic settings .....	77
Data types decoding .....	78

<b>APPENDIX B: DNP3 PROTOCOL.....</b>	<b>79</b>
DNP3 COMMUNICATION PROTOCOL.....	79
<i>DNP3</i> .....	79
<i>Register table for the actual measurements</i> .....	79
<i>Data types decoding</i> .....	81
<i>100% values calculations</i> .....	81
<b>APPENDIX C: CALCULATIONS &amp; EQUATIONS .....</b>	<b>82</b>
CALCULATIONS .....	82
<i>Definitions of symbols</i> .....	82
EQUATIONS.....	83
<i>Voltage</i> .....	83
<i>Current</i> .....	83
<i>Power</i> .....	84
<i>THD</i> .....	85
<i>Flickers</i> .....	85
<i>Energy</i> .....	85
<b>APPENDIX D: DATA FORMATS .....</b>	<b>86</b>
<i>Explanation of XML data format</i> .....	86
<i>Example of alarms &lt;data&gt; package</i> .....	86
<i>Example of readings &lt;data&gt; package</i> .....	87
<i>Example of acknowledgement package</i> :.....	87





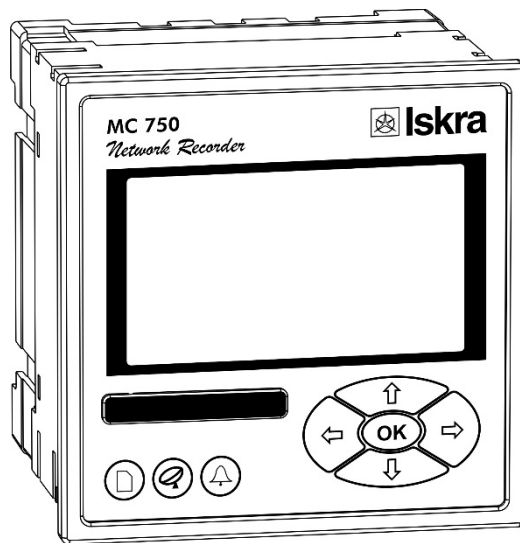

# NETWORK RECORDER - MC750 TH

This booklet contains instructions for installation and use of Measuring centre MC750 TH. Installation and use of devices also includes work with dangerous currents and voltages, therefore should be installed, operated, serviced and maintained by qualified personnel only. The *ISKRA d.d.* company assumes no responsibility in connection with installation and use of the product. If there is any doubt regarding installation and use of the system in which the device is used for measuring or supervision, please contact a person who is responsible for installation of such system.



# WARNINGS, INFORMATION AND NOTES REGARDING DESIGNATION OF THE PRODUCT

Used symbols on devices' housing:

	<p>See product documentation.</p>
	<p>Double insulation in compliance with the <b>EN 61010-1</b> standard.</p>
	<p>Functional ground potential.          Note: This symbol is also used for marking a terminal for protective ground potential if it is used as a part of connection terminal or auxiliary supply terminals.</p>
	<p>Compliance of the product with directive 2002/96/EC, as first priority, the prevention of waste electrical and electronic equipment (WEEE), and in addition, the reuse, recycling and other forms of recovery of such wastes so as to reduce the disposal of waste. It also seeks to improve the environmental performance of all operators involved in the life cycle of electrical and electronic equipment.</p>
	<p>Compliance of the product with European CE directives.</p>

# BEFORE SWITCHING THE DEVICE ON

Check the following before switching on the device:

- Nominal voltage,
- Supply voltage,
- Nominal frequency,
- Voltage ratio and phase sequence,
- Current transformer ratio and terminals integrity,
- Protection fuse (recommended maximal external fuse size is 6 A – a type with a red dot or equivalent),
- Integrity of earth terminals (where necessary)



## CAUTION

A current transformer secondary should be short circuited before connecting the device.

# DEVICE SWITCH OFF WARNING

Auxiliary supply circuits for (external) relays can include capacitors between supply and ground. In order to prevent electrical shock hazard, the capacitors should be discharged via external terminals after having completely disconnected auxiliary supply (both poles of any DC supply).

# HEALTH AND SAFETY

The purpose of this chapter is to provide a user with information on safe installation and handling with the product in order to assure its correct use and continuous operation.

We expect that everyone using the product will be familiar with the contents of chapter »Security Advices and Warnings«.

If equipment is used in a manner not specified by the manufacturer, the protection provided by the equipment may be impaired.

# REAL TIME CLOCK

As a backup power supply for Real time clock supercapacitor or battery is built in. Support time with supercapacitor is up to 2 days (after each power supply down), with battery 6 years from manufacture.

# DISPOSAL

It is forbidden to deposit electrical and electronic equipment as municipal waste. The manufacturer or provider shall take waste electrical and electronic equipment free of charge. The complete procedure after lifetime should comply with the Directive EZ 2002/96/EG about restriction on the use of certain hazardous substances in electrical and electronic equipment or a corresponding Url 118/04.

# BASIC DESCRIPTION AND OPERATION

## Glossary

Term	Explanation
AC	Alternating voltage
AI	Analogue input module
AL	Alarm output module
AO	Analogue output module
BO	Bistable alarm output module
COM2	2 <sup>nd</sup> communication port module
COMEX	Communication port module for Analogue extender EX104
DI	Digital input module
Ethernet	IEEE 802.3 data layer protocol
FFT graphs	Graphical display of presence of harmonics
Flash	Type of a memory module that keeps its content in case of power supply failure
Flicker	Voltage fluctuation causes changes of luminous intensity of lamps, which causes the so-called flicker
Hand-over place	Connection spot of consumer installation in public network
Harmonic voltage - harmonic	Sine voltage with frequency equal to integer multiple of basic frequency
Hysteresis expressed as percentage [%]	Percentage specifies increase or decrease of a measurement from a certain limit after exceeding it.
MD	Maximum demand measurement in time interval
Memory card	Multimedia memory card. Type MMC and SD supported
MiQen	Software for <i>Iskra</i> devices
MODBUS / DNP3	Industrial protocol for data transmission
$M_p$ - Average interval	Defines frequency of refreshing displayed measurements on the basis of a Sample factor
$M_v$ - Sample factor	Defines a number of periods for measuring calculation on the basis of measured frequency
PA total	Angle calculated from total active and apparent power
PA1, PA2, PA3	Angle between fundamental phase voltage and phase current
PF	Power factor
PI	Pulse input module
PO	Pulse output module
RMS	Root Mean Square value
RTC	Real Time Clock
THD	Total harmonic distortion
TI	Tariff input module
WO	Watch dog module - for supervision of operation

## Description of the product

A measuring centre is used for measuring, analysing and monitoring three phase electrical power network. Using the latest technologies and numerical methods we have reached high accuracy over a wide measuring range of voltage, current and integrated quantities.

### Appearance

The device figure can differ from yours depending on the type.

- 1 - Graphical LCD
- 2 - Navigation keyboard
- 3 - A slot with a cover for memory card
- 4 - LED indicators

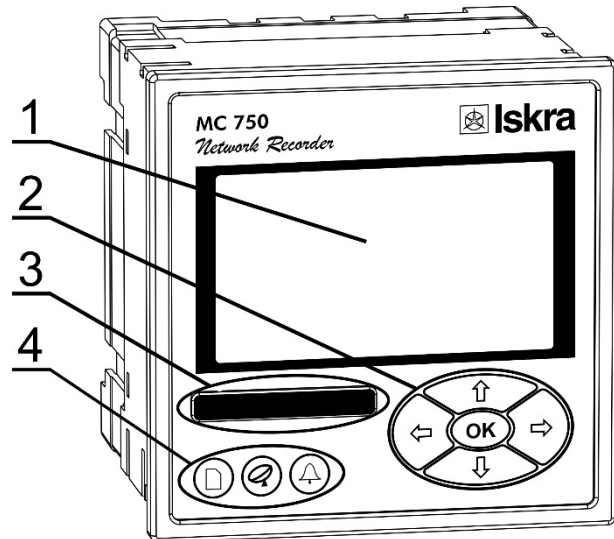

#### GRAPHICAL LCD

A graphical LCD with back light is used for high resolution of displayed measuring quantities and for a display of selected functions when setting the device.

#### NAVIGATION KEYBOARD

The "OK" key is used for confirming the settings, selecting and exiting the display. Direction keys are used for shifting between screens and menus.

#### A SLOT WITH A COVER FOR MMC OR SD MEMORY CARD

The device is provided with a slot for a full size MMC or SD card that is used for data transfer from the internal memory, device setting and software upgrading. A slot protection cover for the card prevents penetration of humidity and dust into device.

#### LED INDICATORS

LED indicators warn of a certain state of the device. A left (red) indicator indicates the card activity and that it should not be pulled out (Can also be used as LED Energy Counter – for more information please see chapter Settings / Energy - counters on page 36). A middle (green) one is blinking when transmitting MC data via communication. A right (red) one is blinking when the condition for the alarm is fulfilled.

## Purpose and use of MC750 TH Network Recorder

### Network recorder

The device is used for monitoring, measuring and recording measurements of electric quantities of electrical power distribution system. Up to 64 measurements and up to 32 alarms are recorded in the internal memory. The memory is separated into four sections for measurements (A, B, C and D) and one section for recording alarms. The memory division is defined by the user via communication or a memory card.

## Supported measurements for recorder

Basic measurements	
Phase	Voltage $U_1, U_2, U_3$ and $U_{\sim}$
	Current $I_1, I_2, I_3, I_n, I_t$ and $I_a$
	Active power $P_1, P_2, P_3,$ and $P_t$
	Reactive power $Q_1, Q_2, Q_3,$ and $Q_t$
	Apparent power $S_1, S_2, S_3,$ and $S_t$
	Power factor $PF_1, PF_2, PF_3$ and $PF_{\sim}$
	Power angle $\phi_1, \phi_2, \phi_3$ and $\phi_{\sim}$
	THD of phase voltage $U_{f1}, U_{f2}$ and $U_{f3}$
	THD of power angle $I_1, I_2$ and $I_3$
Phase-to-phase	Phase-to-phase voltage $U_{12}, U_{23}, U_{31}$
	Average phase-to-phase voltage $U_{ff}$
	Phase-to-phase angle $\phi_{12}, \phi_{23}, \phi_{31}$
	Voltage unbalance $U_u$
	THD of phase-to-phase voltage
Energy	Counter 1
	Counter 2
	Counter 3
	Counter 4
	Total tariff
	Active tariff
	Cost by counters
	Total cost

Other measurements	
Min / Max	Voltage $U_1, U_2, U_3$
	Phase-to-phase voltage $U_{12}, U_{23}, U_{31}$
	Phase current $I_1, I_2, I_3$
	Active power $P_1, P_2, P_3, P$
	Apparent power $S_1, S_2, S_3, S$
	Frequency $f$
	Internal temperature
MD values	Phase current $I_1, I_2, I_3$
	Active power $P$ (Positive)
	Active power $P$ (Negative)
	Reactive power $Q - L$
	Reactive power $Q - C$
Apparent power $S$	
Measurement	Frequency
	Internal temperature
	Date & Time
	Time graphs ( $I_1, I_2, I_3, U_1, U_2, U_3, U_{12}, U_{23}$ and $U_{31}$ )
	FFT graphs ( $I_1, I_2, I_3, U_1, U_2, U_3, U_{12}, U_{23}$ and $U_{31}$ )
	Phase voltage harmonics
	Phase-to-phase voltage harmonics
	Current harmonics

Harmonics up to 63<sup>rd</sup>

Flicker  $P_i$  and  $P_{im}$  on display only.

# CONNECTION

## Introduction

This chapter deals with the instructions for measuring centre connection. Both the use and connection of the device includes handling with dangerous currents and voltages. Connection shall therefore be performed by a qualified person. *Iskra, d.d.* does not take any responsibility regarding the use and connection. If any doubt occurs regarding connection and use in the system which device is intended for, please contact a person who is responsible for such installations.

**Before use:** Check voltages and phase rotation, proper supply voltage and nominal frequency and proper voltage level of used I/O modules.

Check protective fuse rating (the recommended maximum rating of the external protective fuse for this equipment is 6A - Red Spot type or equivalent).

### WARNING!

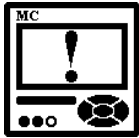

Wrong or incomplete connection of voltage or other terminals can cause non-operation or damage to the device.

### PLEASE NOTE



After connection, settings have to be performed via a keyboard on the front side of the device that reflect connection of device to voltage network (connection mode, current and voltage transformers ratio ...). Settings can also be done via communication or a memory card.

## Mounting

Before inserting device into the panel cut out, remove four screws, insert device and position the screws correctly. Fix device to the panel.

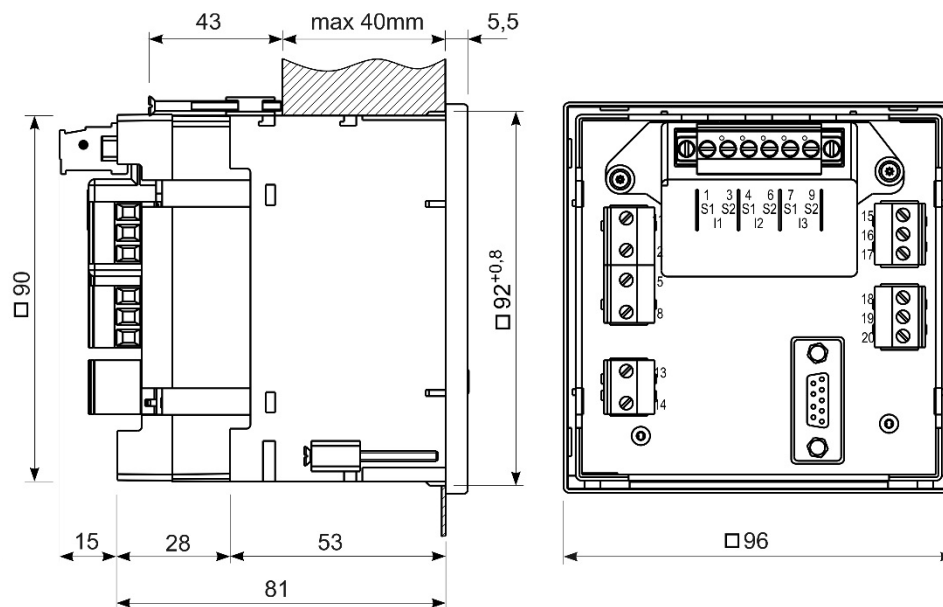

Panel cut out:  
DIN 92 x 92 mm <sup>+0.8</sup>

Remove protection foil from the screen.

## Electric connection

Voltage inputs of measuring centre can be connected directly to low-voltage network or via a voltage measuring transformer to high-voltage network.

Current inputs shall be connected to network via a corresponding current transformer.

Choose corresponding connection from the figures below and connect corresponding voltages and currents. Information on electrical consumption of current and voltage inputs is given in chapter *Inputs* on page 65.

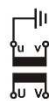
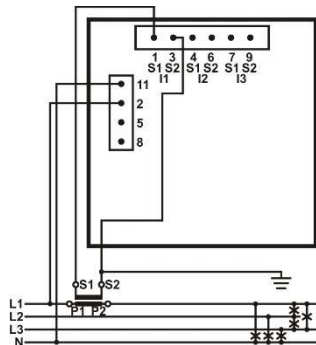

Connection 1b (1W1b);  
Single phase connection

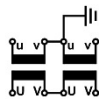
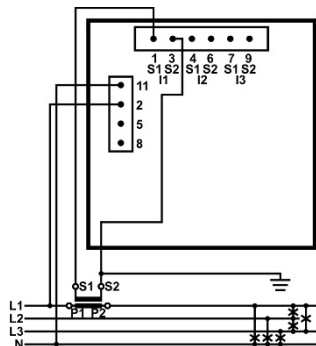

Connection 3b (1W3b)  
Three phase, three wire connection with balanced load

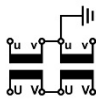
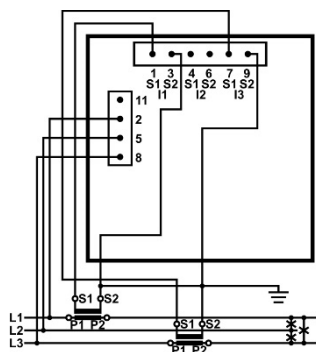

Connection 3u (2W3u)  
Three phase, three wire connection with unbalanced load

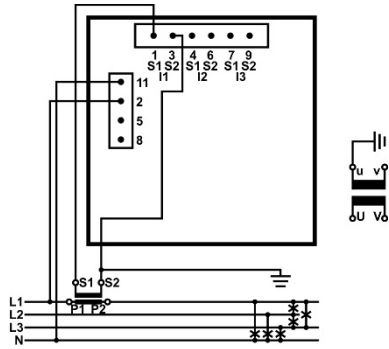

Connection 4b (1W4b)  
Three phase, four wire connection with balanced load

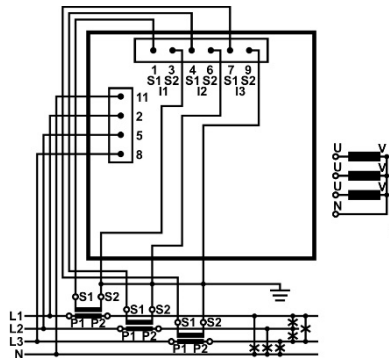

Connection 4u (3W4u)  
Three phase, four wire connection with unbalanced load



PLEASE NOTE



Connection does not depend on a number of built-in modules and communication and is shown on the device label.

## Connection of input/output modules



WARNING!

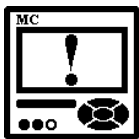

Check the module features that are specified on the label, before connecting module contacts. Wrong connection can cause damage or destruction of module and/or device.



PLEASE NOTE



Frequency of the tariff input voltage signal should not essentially deviate from the frequency of the measuring input signal. At no signal on the measuring inputs the tariff triggering is not reliable.

Connect module contacts as specified on the label. Examples of labels are given below and describe modules built in the device. Information on electrical properties of modules is given in chapter *Modules* on page 66.

<table border="1"> <tr><td><b>INPUT/OUTPUT</b></td></tr> <tr><td>Module 1:</td></tr> <tr><td>2 X Tarif input</td></tr> <tr><td>U=230V AC ±20%</td></tr> <tr><td> T1/2 15</td></tr> <tr><td> C 16</td></tr> <tr><td> T3/4 17</td></tr> </table>	<b>INPUT/OUTPUT</b>	Module 1:	2 X Tarif input	U=230V AC ±20%	T1/2 15	C 16	T3/4 17	<p>Tariff input module with two tariff inputs for changeover between up to four tariffs.</p>
<b>INPUT/OUTPUT</b>								
Module 1:								
2 X Tarif input								
U=230V AC ±20%								
T1/2 15								
C 16								
T3/4 17								
<table border="1"> <tr><td><b>INPUT/OUTPUT</b></td></tr> <tr><td>Module 1:</td></tr> <tr><td>2 X Alarm output</td></tr> <tr><td>U<sub>max</sub>=40V I<sub>max</sub>=1A</td></tr> <tr><td> A1 15</td></tr> <tr><td> C1 16</td></tr> <tr><td> A2 17</td></tr> </table>	<b>INPUT/OUTPUT</b>	Module 1:	2 X Alarm output	U <sub>max</sub> =40V I <sub>max</sub> =1A	A1 15	C1 16	A2 17	<p>Alarm (relay) output module with two outputs.</p>
<b>INPUT/OUTPUT</b>								
Module 1:								
2 X Alarm output								
U <sub>max</sub> =40V I <sub>max</sub> =1A								
A1 15								
C1 16								
A2 17								
<table border="1"> <tr><td><b>INPUT/OUTPUT</b></td></tr> <tr><td>Module 1:</td></tr> <tr><td>1 X Bistab. al. output</td></tr> <tr><td>U<sub>max</sub>=40V I<sub>max</sub>=1A</td></tr> <tr><td> No 15</td></tr> <tr><td> C1 16</td></tr> <tr><td> Nc 17</td></tr> </table>	<b>INPUT/OUTPUT</b>	Module 1:	1 X Bistab. al. output	U <sub>max</sub> =40V I <sub>max</sub> =1A	No 15	C1 16	Nc 17	<p>Bistable alarm output module; keeps the state also in case of device power supply failure.</p>
<b>INPUT/OUTPUT</b>								
Module 1:								
1 X Bistab. al. output								
U <sub>max</sub> =40V I <sub>max</sub> =1A								
No 15								
C1 16								
Nc 17								
<table border="1"> <tr><td><b>INPUT/OUTPUT</b></td></tr> <tr><td>Module 1:</td></tr> <tr><td>2 X Pulse output</td></tr> <tr><td>U<sub>max</sub>=40V I<sub>max</sub>=30mA</td></tr> <tr><td> P1 15</td></tr> <tr><td> C1 16</td></tr> <tr><td> P2 17</td></tr> </table>	<b>INPUT/OUTPUT</b>	Module 1:	2 X Pulse output	U <sub>max</sub> =40V I <sub>max</sub> =30mA	P1 15	C1 16	P2 17	<p>Pulse output (solid state) module with two pulse outputs for energy counters.</p>
<b>INPUT/OUTPUT</b>								
Module 1:								
2 X Pulse output								
U <sub>max</sub> =40V I <sub>max</sub> =30mA								
P1 15								
C1 16								
P2 17								
<table border="1"> <tr><td><b>INPUT/OUTPUT</b></td></tr> <tr><td>Module 1:</td></tr> <tr><td>2 X Analog output</td></tr> <tr><td>0...20mA R<sub>max</sub>=150Ω</td></tr> <tr><td> A1+ 15</td></tr> <tr><td> C1- 16</td></tr> <tr><td> A2+ 17</td></tr> </table>	<b>INPUT/OUTPUT</b>	Module 1:	2 X Analog output	0...20mA R <sub>max</sub> =150Ω	A1+ 15	C1- 16	A2+ 17	<p>Analogue output module with two analogue outputs (0...20mA), proportional to measured quantities.</p>
<b>INPUT/OUTPUT</b>								
Module 1:								
2 X Analog output								
0...20mA R <sub>max</sub> =150Ω								
A1+ 15								
C1- 16								
A2+ 17								
<table border="1"> <tr><td><b>INPUT/OUTPUT</b></td></tr> <tr><td>Module 1:</td></tr> <tr><td>2 X Digital input</td></tr> <tr><td>U=230V AC ±20%</td></tr> <tr><td> D1 15</td></tr> <tr><td> C 16</td></tr> <tr><td> D2 17</td></tr> </table>	<b>INPUT/OUTPUT</b>	Module 1:	2 X Digital input	U=230V AC ±20%	D1 15	C 16	D2 17	<p>Digital input module with two digital inputs enables reception of impulse signals.</p>
<b>INPUT/OUTPUT</b>								
Module 1:								
2 X Digital input								
U=230V AC ±20%								
D1 15								
C 16								
D2 17								
<table border="1"> <tr><td><b>INPUT/OUTPUT</b></td></tr> <tr><td>Module 2:</td></tr> <tr><td>1 X Communication</td></tr> <tr><td>RS232</td></tr> <tr><td> Rx 18</td></tr> <tr><td> 19</td></tr> <tr><td> Tx 20</td></tr> </table>	<b>INPUT/OUTPUT</b>	Module 2:	1 X Communication	RS232	Rx 18	19	Tx 20	<p>2<sup>nd</sup> communication module, for connection of RS232 communication (COM2).</p>
<b>INPUT/OUTPUT</b>								
Module 2:								
1 X Communication								
RS232								
Rx 18								
19								
Tx 20								
<table border="1"> <tr><td><b>INPUT/OUTPUT</b></td></tr> <tr><td>Module 2:</td></tr> <tr><td>1 X Communication</td></tr> <tr><td>RS485</td></tr> <tr><td> A 18</td></tr> <tr><td> C 19</td></tr> <tr><td> B 20</td></tr> </table>	<b>INPUT/OUTPUT</b>	Module 2:	1 X Communication	RS485	A 18	C 19	B 20	<p>2<sup>nd</sup> communication module, for connection of RS485 communication (COM2).</p>
<b>INPUT/OUTPUT</b>								
Module 2:								
1 X Communication								
RS485								
A 18								
C 19								
B 20								
<table border="1"> <tr><td>I/O 3/4</td></tr> <tr><td>COM2</td></tr> <tr><td>Output Ex. A 18</td></tr> <tr><td>NC 19</td></tr> <tr><td>B 20</td></tr> </table>	I/O 3/4	COM2	Output Ex. A 18	NC 19	B 20	<p>Communication module, for connection of Analogue extender EX104</p>		
I/O 3/4								
COM2								
Output Ex. A 18								
NC 19								
B 20								
<table border="1"> <tr><td>I/O 1/2</td></tr> <tr><td>2 x Pulse input</td></tr> <tr><td>5...48 V DC</td></tr> <tr><td>1+ 15</td></tr> <tr><td>- 16</td></tr> <tr><td>2+ 17</td></tr> </table>	I/O 1/2	2 x Pulse input	5...48 V DC	1+ 15	- 16	2+ 17	<p>Pulse input module enables reception of pulses from various counters (water, gas, heat, flow ...).</p>	
I/O 1/2								
2 x Pulse input								
5...48 V DC								
1+ 15								
- 16								
2+ 17								
<table border="1"> <tr><td>I/O 1/2</td></tr> <tr><td>2 x Analogue input</td></tr> <tr><td>-10...0...10 V</td></tr> <tr><td>1+ 15</td></tr> <tr><td>- 16</td></tr> <tr><td>2+ 17</td></tr> </table>	I/O 1/2	2 x Analogue input	-10...0...10 V	1+ 15	- 16	2+ 17	<p>Analogue input module enables measurements of DC U, I, R or temp. (PT100, PT1000) values from external sources. Modules have different hardware, so programming is possible within one quantity.</p>	
I/O 1/2								
2 x Analogue input								
-10...0...10 V								
1+ 15								
- 16								
2+ 17								
<table border="1"> <tr><td>I/O 3/4</td></tr> <tr><td>Watchdog / Relay output</td></tr> <tr><td>35 V DC 1+ 18</td></tr> <tr><td>40 V AC 1- 19</td></tr> <tr><td>1000 mA 2+ 20</td></tr> </table>	I/O 3/4	Watchdog / Relay output	35 V DC 1+ 18	40 V AC 1- 19	1000 mA 2+ 20	<p>Watchdog output and alarm (relay) module enables proper device operation supervision</p>		
I/O 3/4								
Watchdog / Relay output								
35 V DC 1+ 18								
40 V AC 1- 19								
1000 mA 2+ 20								

## Communication connection

A type of connector depends on ordered specification. Primary RS232 and RS485 communication can be equipped with DB9 terminal or screw terminal connector, RJ - 45 terminal is used for Ethernet communication and USB-B type terminal for USB communication. Secondary serial communication, COM2 additional communication module (RS232 or RS485), is equipped with screw terminal connector.

### WARNING!

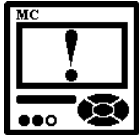

When connecting primary serial communication, either equipped with a DB9 communication connector or screw terminal connector, it is necessary to assure that only RS232 or RS485 communication is used. Terminals of a connector that are not necessary for the used communication should remain unconnected, otherwise the communication module and/or device can be damaged or destroyed. For proper connection see a table on page 17.

If device has built in secondary communication as a COM2 module (RS232 or RS485), one primary communication and secondary communication can be used at the same time, since they are independent from each other.

Connect a communication line by means of a corresponding terminal. Corresponding data are stated on the device label, regarding the selected communication. Connector terminals are marked on the label on the upper side of the device. More detailed information on communication is given in chapter *Communication* on page 30.

COMMUNICATION					
RS232			RS485		
Tx	Rx	↓	B	A	
2	3	5	7	8	

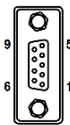

Data for RS232 and RS485 communication with DB9 connector

COMMUNICATION TERMINAL					
RS232			RS485		
Rx	↓	Tx	A	B	
25	26	27	23	24	

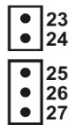

Data for RS232 and RS485 communication with pluggable screw terminal connector

COMMUNICATION					
Ethernet					
TD+	TD-	RD+	RD-		
1	2	3	6		
Mac N°:00-20-4A-8A-94-13					

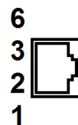

Data for Ethernet communication with RJ - 45 connector



USB-B type connector

## RS232

RS232 communication is intended for direct connection of the Measuring centre to the personal computer. For proper operation it is necessary to assure the corresponding connection of individual terminals (see table on next page).

**Serial RS232 as secondary communication, COM2 additional communication module**  
Operates as an independent communication. Separate communication parameters can be set for this communication module.

## RS485

RS485 communication is intended for connection of devices to network where several devices with RS485 communication are connected to a common communication interface. We suggest using one of the *ISKRA, d.d.* communication interfaces! For proper operation it is necessary to assure the corresponding connection of individual terminals (see table on next page).

**Serial RS485 as secondary communication, COM2 additional communication module**  
 Operates as an independent communication. Separate communication parameters can be set for this communication module.

**Communication for Analogue extender EX104, COM2 additional communication module**  
 Operates as a predefined RS485 communication that can be used for data transfer between measuring centre and analogue extenders EX104.

## Ethernet

Ethernet communication is used for connection of device to the Ethernet network for remote inspection. Each device has its own MAC code that at some cases needs to be provided and is printed on the label on the device. For operation correct connection of individual terminals of the RJ-45 connector (see a table on the next page).

## USB

USB communication serves as a fast peer-to-terminal data link. The device is detected by host as a USB 2.0 compatible device. The USB connection is provided through a USB standard Type B connector.









### PLEASE NOTE

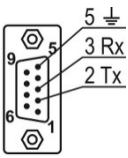

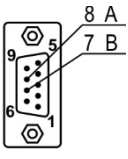
When device is connected to a PC through USB communication for the first time, a user is prompted to install a driver. The driver is integrated in MiQen software or can be downloaded from the *Iskra, d.d.* web page <http://www.iskra.eu/>. With this driver installed, USB is redirected to a serial port, which should be selected when using MiQen software.

## Survey of communication connection

	Connector	Position	Terminals	Position	Data direction	Description
RS232		3		27	From	Data reception (Rx)
		5		26	-	Grounding
		2		25	To	Data transmission (Tx)
RS485		8		23	To/From	A
		7		24	To/From	B
Ethernet				100BASE-T CAT5 cable recommended		
USB				Standard USB 2.0 compatible cable recommended (Type B plug)		

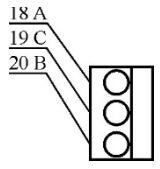

## Survey of communication connection for Analogue extender EX104

	Connector	Terminals	Position	Data direction	Description
Com. for EX104	Screw terminal		18	To/From	A
			19	-	Do not connect!
			20	To/From	B



## Connection of power supply

Measuring centre has adaptable power supply. It enables connection to certain AC power supply or universal (AC/DC) power supply. Power supply voltage depends on ordered voltage. Information on electric consumption is given in chapter *Technical data* on page 64.

Regarding power supply voltage specification on the label choose and connect the power supply voltage:

INPUTS		
Current: 5 A		
Voltage: 240 V		
Frequency: 50 Hz		
Connection: 4u		
SUPPLY:		
20...300 V DC < 12VA		
48...276 V; 40...70 Hz		
Terminal	13	
	14	

Connection of universal power supply to terminals 13 and 14.

INPUTS		
Current: 5 A		
Voltage: 500 V		
Frequency: 50 Hz		
Connection: 4u		
SUPPLY:		
230 V AC		
45...65 Hz		
Terminal	13	
	14	

Connection of AC power supply to terminals 13 and 14.

# FIRST STEPS

## Introduction

Instruction for work with measuring centre is given in the following chapters.



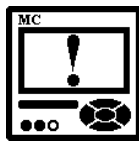

### WARNING!



Measuring centre start-up begins after electrical connection. After proper connection it is assured that the user security is not threatened. After correct switch-on and respected safety measures the work with device does not represent any danger for a user.



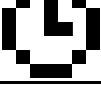

## Basic concepts

Navigation keys and LCD enable application and basic device settings. During the operation some icons can be displayed in upper part of LCD. The significance of icons (from right to left) is explained in the table below.

Icon	Meaning
	Device is locked with a password of the second level (L2). The first level (L1) can be unlocked.
	Device can be wrongly connected at 4u connection. Energy flow direction is different by phases.
	A built-in battery (for RTC) shall be replaced. A battery test is carried out at power supply connection (for devices with built in battery)
	The device supply is too low.
	Clock not set (for devices with built in super cap)

Example:

 Main menu ⇒ Info OK ↑

Info
 Locked
 Wrong connection
 Low battery
 Low supply
 Main menu

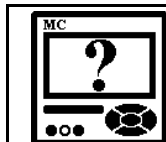

Meaning of icons is displayed on LCD in the Information menu.

## Installation wizard

After installation and electrical connection, basic parameters have to be set in order to assure correct operation. The easiest way to achieve that is use the Installation wizard. When entering the Installation menu, settings follow one another when the previous one is confirmed. All required parameters shall be entered and confirmed. Exit from the menu is possible when all required settings are confirmed or with interruption (key  $\leftarrow$  several times) without changes.

Installation wizard menu may vary, depending on built in communication modules. In description below is marked which menu appears for specific option.



### PLEASE NOTE



All settings that are performed through the Installation wizard can be subsequently changed by means of the Settings menu or via MiQen by means of communication or a Memory card.



Main menu  $\Rightarrow$  Installation  $\Rightarrow$

The menus follow one after another:

### START MENU

Start screen is displayed on LCD.

### LANGUAGE

Set device language.

### DATE

Set device date.

### TIME

Set device time.

### CONNECTION MODE

Choose connection and define load connection.

### PRIMARY VOLTAGE

Set primary voltage if a voltage transformer is used.

### SECONDARY VOLTAGE

Set secondary voltage if a voltage transformer is used; set voltage of low voltage network if connection is direct.

### PRIMARY CURRENT

Set primary current of a used current transformer (if current transformer is used, otherwise primary and secondary current should remain the same).

### SECONDARY CURRENT

Set secondary current.

### COMMON ENERGY EXPONENT (COMMON ENERGY COUNTER RESOLUTION - MIQEN 2.X AND ABOVE)

Define common energy exponent as recommended in table below, where counter divider is at default value 10. Values of primary voltage and current determine proper Common energy exponent. For detailed information see chapter *Energy* on page 35.

In MiQen setting software version 2.x and above, this setting parameter is renamed in Common Energy Counter Resolution. Also setting values are changed to give user better perspective of represented value. In table below, new setting values are quoted in parenthesis.

Current Voltage	1 A	5 A	50 A	100 A	1000 A
110 V	-1 (100 mWh)	0 (1 Wh)	1 (10 Wh)	1 (10 Wh)	2 (100 Wh)
230 V	0 (1 Wh)	0 (1 Wh)	1 (10 Wh)	2 (100 Wh)	3 (1 kWh)
1000 V	0 (1 Wh)	1 (10 Wh)	2 (100 Wh)	3 (1 kWh)	4 (10 kWh)
30 kV	2 (100 Wh)	2 (100 Wh)	3 (1 kWh)	4 (10 kWh)	4* (10 kWh)

\* - Counter divider (MiQen 2.x and above - Individual Counter Resolution) should be at least 100

## DEVICE ADDRESS

Set MODBUS address for the device. Default address is 33.

## BITS PER SECOND (IF RS232 / RS485 COMMUNICATION IS BUILT IN)

Set communication rate. Default rate is 115200 b/s.

## PARITY (IF RS232 / RS485 COMMUNICATION IS BUILT IN)

Set communication parity. Default value is None.

## STOP BIT (IF RS232 / RS485 COMMUNICATION IS BUILT IN)

Set communication stop bits. Default value is 2.

## IP ADDRESS (IF ETHERNET COMMUNICATION IS BUILT IN)

Set correct IP address of the device. Default setting is 0.0.0.0 and represents DHCP addressing.

## TCP PORT (IF ETHERNET COMMUNICATION IS BUILT IN)

Set TCP communication Port. Default value is 10001.

## SUBNET MASK (IF ETHERNET COMMUNICATION IS BUILT IN)

Set network subnet mask. Default value is 255.255.255.0

## Display of device info

A menu is divided into several submenus with data and information about device:

- Welcome screen
- Information
- Memory
- Time, date, internal temperature and tariff status
- Meaning of icons

### Welcome screen

When entering the information menu, a welcome screen is displayed on LCD showing type designation and name of measuring centre.

 Main menu ⇒ Info OK

### Information

Data on a device are collected in the Information menu. They include a serial number, a software version, a hardware version, date of manufacture and a number of operational hours in days, hours and minutes.

 Main menu ⇒ Info OK ↓

## Memory

A memory state is displayed in two ways. In a basic display the recording time or a number of records until a scale division is full is displayed, since the last official reading. A graphical display of occupation of individual scale division is used as a help. A more detailed display shows a number of records of a maximal number for each scale division.

 Main menu ⇒ Info OK ↓ ↓ ↓

User information



More data can be stored in the internal memory than displayed, since the display depends upon the official transfer. For transfer of all available data to memory card or via communication “All data” should be selected when saving data.

## Time, date and temperature

Data on current date, time, internal temperature and tariff status in submenu are displayed on LCD.

 Main menu ⇒ Info OK ↓ ↓ ↓ ↓ (⇒)

## Meaning of icons

All possible icons with their meaning are displayed.

 Main menu ⇒ Info OK ↓ ↓ ↓ ↓ ↓

 Example of display of icons with their meaning without active icons and at locked MC:

<pre>Info ┌ Locked │ ¥ Wrong connection │ □ Low battery │ ⊕ Low supply └ Main menu</pre>	⇒	Time of automatic password activation	⇒	<pre>Info ┌ Locked │ ¥ Wrong connection │ □ Low battery │ ⊕ Low supply └ Main menu</pre>
--	---	--	---	--

 Example for MC760 information display:

<pre>Main menu Settings Resets MMC card Info Installation www.iskra-mis.si</pre>	⇔	<pre>Iskra MIS MC760 Network Analyzer www.iskra-mis.si</pre>	
<pre>Info Ser.#: MC000003 S.ver: 1.00 H.ver: A Date : 19.04.2006 Run : 351d 3h 40' └ Main menu</pre>	⇔	<pre>Memory 8MB Rec.A: 235d Rec.B: 23d18h Alarm: 32762 Q.det: 171074 Q.rep: 2660d └ Main menu</pre>	<pre>Memory 8MB Rec.A: 3577/ 37464 Rec.B: 35773/ 70000 Alarm: 6/ 32768 Q.det: 5182/176256 Q.rep: 4/ 384 └ Info</pre>
<pre>Info 09.06.2006 12:19:04 Temperature 42.5°C</pre>	⇔	<pre>Tariff status Tariff input Selected: T1 └ Info</pre>	
<pre>Info ┌ Locked │ ¥ Wrong connection │ □ Low battery │ ⊕ Low supply └ Main menu</pre>			

# SETTINGS

---

## Introduction

Settings of measuring centre can be done via the front keyboard or with a PC and MiQen software. Setting is easier using MiQen. Basic and simpler settings are accessible via navigation keyboard. For new setting to be activated settings file should be transferred to the device via communication (MiQen) or memory card. Setting done via navigation keyboard comes in to function after confirmation (OK).

---

## MiQen software

MiQen software is a tool for complete monitoring of the measuring devices. RS485/RS232, USB/TCP/IP communication is used for connection with a PC. A user-friendly interface consists of five segments: devices management, device settings, real-time measurements, data analysis and software upgrading.

### Devices management

In MiQen it is very easy to manage devices. If dealing with the same device, it can be easily selected from a favourite's line. Use the network explorer to set and explore the devices in serial network or browser for Ethernet devices connected in local Ethernet network. Also setting of communication parameters to establish communication with a single device can easily be done.

### Device settings

Multi Register Edit technology assures a simple modification of settings that are organized in a tree structure. Besides transferring settings into the device, storing and reading from the setting files and memory cards are also available.

### Real-time measurements

All supported measurements can be seen in real time in a table or graphical form. For further processing of the results of measurements, it is possible to set a recorder on active device that will record and save selected measurements to MS Excel .csv file format.

### Data analysis

Analysis can be performed for the devices with a built-in memory. Recorded quantities can be monitored in a tabular or a graphical form. The events that triggered alarms can be analysed or a report on supply voltage quality can be made. All data can be exported to an Access data base, Excel worksheets or as a text file.

### Software upgrading

Always use the latest version of software, both MiQen and software in the device. The program automatically informs you about available upgrades that can be transferred and used for upgrading.



PLEASE NOTE

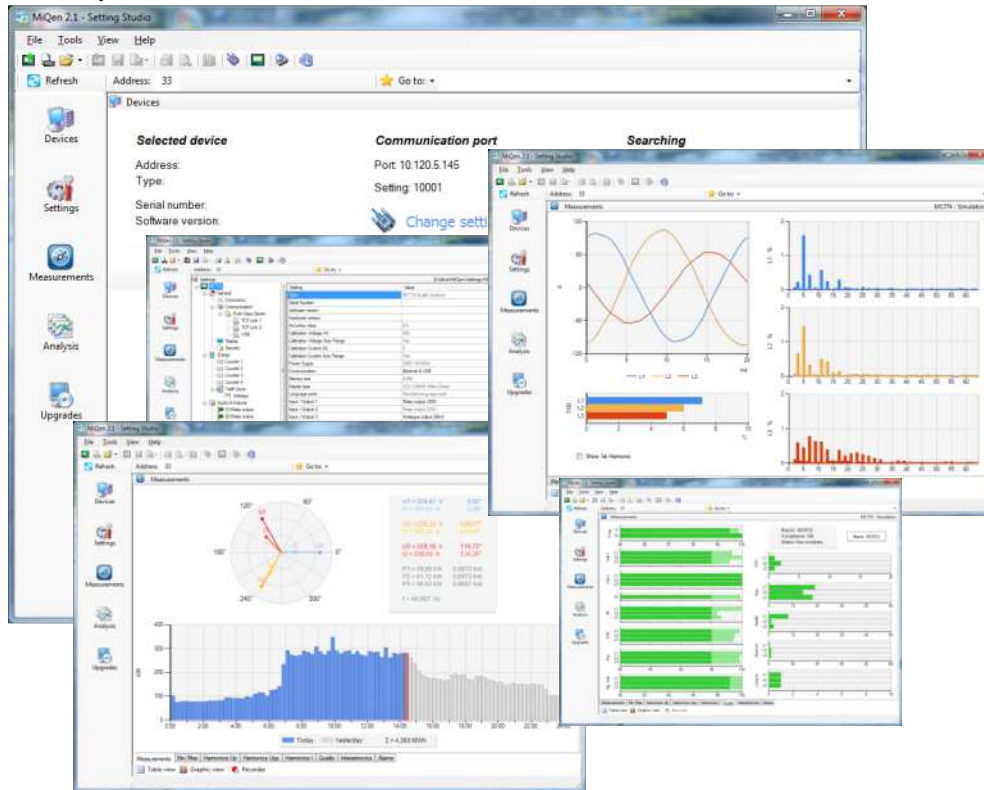

More information about MiQen software can be found in MiQen Help system!

**PC** MiQen 2.x user interface

**PLEASE NOTE**

 You can download freeware MiQen from: <http://www.iskra.eu/>

## Setting procedure

Before setting the device by means of MiQen, the current settings should be read first. Reading is available either via communication (RS232/RS485, USB/Ethernet) or from a file stored on a PC local disk or a Memory. A setting structure that is similar to a file structure in an explorer is displayed in the left part of the MiQen setting window. Available settings of that segment are displayed in the right part by clicking any of the stated parameters.

## General settings

General settings are essential for measuring centre. They are divided into four additional sublevels (Connection, Communication, Display and Security).

### Description and Location **PC** **MC**

These two parameters are intended for easier recognition of a certain unit. They are especially used for identification of the device or location on which measurements are performed.

### Average interval **PC** **MC**

The averaging interval defines a refresh rate of measurements on LCD, communication and analogue outputs. It also defines response time for alarms set to Normal response and average interval used when Minimum or Maximum values are selected to be recorded.

## Language

Set language on LCD. When language is changed from or to Russian, characters of the password are changed too. For overview of character translation see chapter *Password and language* on page 34.

Main menu ⇒ Settings ⇒ General ⇒ Language

### PLEASE NOTE



If a wrong language is set, a menu of languages can be displayed by simultaneous pressing up and down keys.

## Currency

Choose currency for evaluating energy cost (see chapter *Energy* on page 35). A currency designation consists of up to four letters taken from the English or Russian alphabet and numbers and symbols stated in table below.

English	A	B	C	D	E	F	G	H	I	J	K	L	M	N	O	P	Q	R	S	T	U	V	W	X	Y	Z
	a	b	c	d	e	f	g	h	i	j	k	l	m	n	o	p	q	r	s	t	u	v	w	x	y	z
Symbols		!	"	#	\$	%	&	'	(	)	*	+	,	-	.	/	0 to 9	:	;	<	=	>	?	@		
Russian	А	Б	В	Г	Д	Е	Ж	З	И	Й	К	Л	М	Н	О	П	Р	С	Т	У	Ф	Х	Ц	Ч	Ш	Щ
	а	б	в	г	д	е	ж	з	и	й	к	л	м	н	о	п	р	с	т	у	ф	х	ц	ч	ш	щ

Main menu ⇒ Settings ⇒ General ⇒ Currency

## Temperature unit

Choose a unit for temperature display.

Main menu ⇒ Settings ⇒ General ⇒ Temperature unit

## Date format

Set a date format.

Main menu ⇒ Settings ⇒ Date & Time ⇒ Date format

## Date and time

Set date and time of the device. Setting is important for correct memory operation, maximal values (MD), etc.

Main menu ⇒ Settings ⇒ Date & Time ⇒ Date / Time

## Time Synchronisation source

Enable or disable NTP synchronisation. To set NTP server check chapter *Ethernet communication* on page 31. Functionality supported only for devices with built in Ethernet module with Firmware version 5.6 and above!

## Time zone

Set time zone in which device is mounted.

## Auto Summer/Winter time

If Yes is chosen, time will be automatically shifted to a winter or a summer time, regarding the time that is momentarily set.

Main menu ⇒ Settings ⇒ Date & Time ⇒ Automatic S/W time

## Maximum demand calculation (MD mode)

The device provides maximum demand values from a variety of average demand values:

- Thermal function
- Fixed window
- Sliding windows (up to 15)



Main menu ⇒ Settings ⇒ General ⇒ MD mode / MD time constant

### THERMAL FUNCTION

A thermal function assures exponent thermal characteristic based on simulation of bimetal meters.

Maximal values and time of their occurrence are stored in device. A time constant (t. c.) can be set from 1 to 255 minutes and is 6 – time thermal time constant (t. c. = 6 \* thermal time constant).

Example:

Mode: Thermal function

Time constant: 8 min.

Current MD and maximal MD: Reset at 0 min.

**Thermal function**

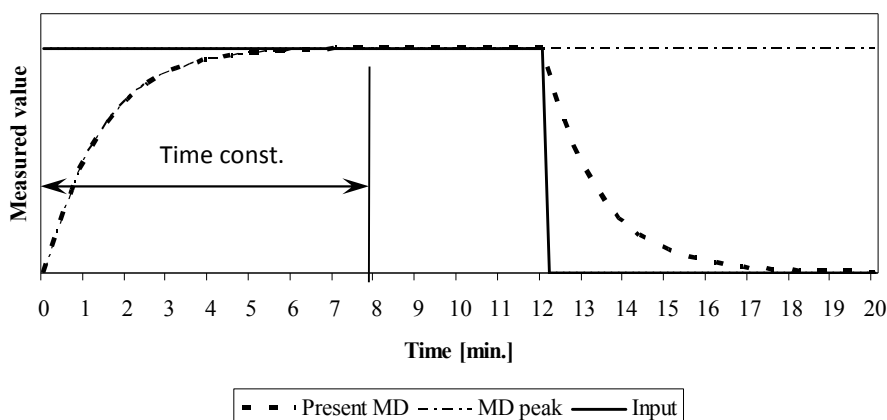

### FIXED WINDOW

A fixed window is a mode that calculates average value over a fixed time period. This (t. c. – time constant) can be set from 1 to 255 min.

»TIME IN A PERIOD« will actively show the remaining time until the end of the period, until a current MD and maximal MD from the last reset are calculated. When displays for Pt(+/-), Qt(L/C), St, I1, I2 and I3 are updated, a new period and measurement of new average values are started. »TIME IN A PERIOD« then shows 0 of X min.

A new period also starts after a longer interruption of power supply (more than 1 s). If time constant is set to one of the values of 2, 3, 4, 5, 6, 10, 12, 15, 20, 30 or 60 minutes, »TIME IN A PERIOD« is set to such value that one of the following intervals will be terminated at a full hour. In other cases of time constants, »TIME IN A PERIOD« is set to 0.

Example:

Mode: Fixed window

Time constant: 8 min.

Current MD and maximal MD: Reset at 0 min.

### Fixed window

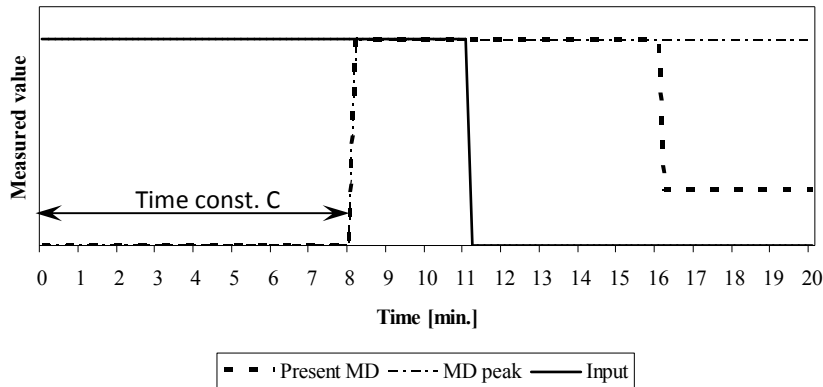

## SLIDING WINDOWS

A mode of sliding windows enables multiple calculation of average in a period and thus more frequent regeneration of measuring results. Average value over a complete period is displayed. A current MD is updated every sub period for average of previous sub periods.

A number of sub periods can be set from 2 to 15.

A time period (t. c.) can be set from 1 to 255 minutes.

A new period also starts after a longer interruption of power supply (more than 1 s). If time constant is set to one of the values of 2, 3, 4, 5, 6, 10, 12, 15, 20, 30 or 60 minutes, »TIME IN A PERIOD« is set to such value that one of the following intervals will be terminated at a full hour. In other cases of time constants, »TIME IN A PERIOD« is set to 0.

Example:

Mode: Sliding windows

Time constant: 2 min.

No. of sub periods: 4

Current MD and maximal MD: Reset at 0 min.

A complete period lasts for 8 minutes and consists of 4 sub periods that are 2 minutes long. A current MD and a maximal MD are reset at 0 min. "TIME IN A PERIOD" is data for a sub period so that the values for a current MD and a maximal MD are regenerated every two minutes. After 4 sub periods (1 complete period) the oldest sub period is eliminated when a new one is added, so that average (a window) always covers the last 4 sub periods.

### Sliding windows

4 subperiods of 2 min.

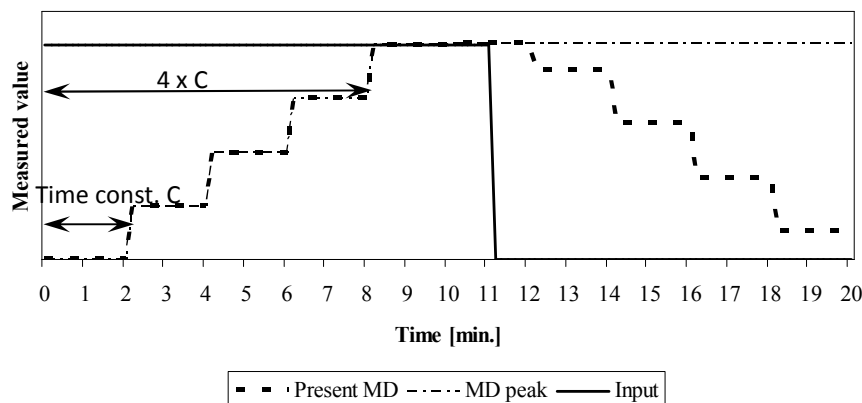

## Resetting Min/Max

A mode of stored values deletion of Min/Max values is set. It can be set to a manual (see chapter *Reset* on page 45) or automatic mode (daily, weekly, monthly or yearly reset). Resets are performed at the beginning of a certain term at midnight. Daily - every day, weekly on Monday at 00:00, monthly - the first day in a month at 00:00, and yearly - the first day in a year 1.1. at 00:00.

 Main menu ⇒ Settings ⇒ General ⇒ Min/Max reset mode

## Starting current for PF and PA (mA)

At all measuring inputs noise is usually present. It is constant and its influence on the accuracy is increased by decreasing measuring signals. It is present also when measuring signals are not connected and it occurs at all further calculations as very sporadic measurements. By setting a common starting current, a limit of input signal is defined where measurements and all other calculations are still performed.

## Starting current for all powers (mA)

Noise is limited with a starting current also at measurements and calculations of powers.

## Calculation of harmonics

Selection of reference for calculation is important for calculation of absolute values of harmonics. It is possible to select between a percentage of harmonic of RMS signal value (current, voltage) or relative to the fundamental (first harmonic). At percentage of RMS, a signal rate is calculated for all harmonics. At percentage of 1st harmonic, all other harmonics are calculated relatively to 1st harmonic.

## Reactive power and energy calculation

User can select between two different principles of reactive power and energy calculation:

Standard method:

With this method a reactive power and energy are calculated based on assumption that all power (energy) that is not active is reactive.

$$Q^2 = S^2 - P^2$$

This means also that all higher harmonics (out of phase with base harmonic) will be measured as reactive power (energy).

Delayed current method:

With this method, reactive power (energy) is calculated by multiplication of voltage samples and delayed current samples (see chapter *Equations* on page 83):

$$Q = U \times I|_{+90^\circ}$$

With this method, reactive power (energy) represents only true reactive component of apparent power (energy).

## Connection



PLEASE NOTE

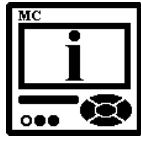

Settings of connections shall reflect actual state otherwise measurements are not valid.

### Connection

When connection is selected, load connection and the supported measurements are defined (see chapter *Survey of supported measurements regarding Connection mode* on page 62).

 Main menu ⇒ Settings ⇒ Connection ⇒ Connection mode

### Setting of current and voltage ratios

Before setting current and voltage ratios it is necessary to be familiar with the conditions in which device will be used. All other measurements and calculations depend on these settings. Up to five decimal places can be set (up / down). To set decimal point and prefix (up / down) position the cursor (left /right) to last (empty) place or the decimal point.

Settings range	VT primary	VT secondary	CT primary	CT secondary
Maximal value	1638.3 kV	13383 V	1638.3 kA	13383 A
Minimal value	0.1 V	1 mV	0.1 A	1 mA

 Main menu ⇒ Settings ⇒ Connection ⇒ VT primary / VT secondary / CT primary / CT secondary

### Used voltage and current range

Setting of the range is connected with all settings of alarms, analogue outputs and a display (calculation) of energy and measurements recording, where 100% represents 500 V. In case of subsequent change of the range, alarms settings shall be correspondingly changed, as well.

### Nominal frequency

Nominal frequency range can be selected from a set of predefined values (16 Hz currently not supported). A valid frequency measurement is within the range of nominal frequency  $\pm 30$  Hz. This setting is used for alarms and recorders only.

### Wrong connection warning

If all phase currents (active powers) do not have same sign (some are positive and some negative) and/or if phase voltages and phase currents are mixed, the warning will be activated if this setting is set to YES. This warning is seen only on remote display.

### Energy flow direction

This setting allows manual change of energy flow direction (IMPORT to EXPORT or vice versa) in readings tab. It has no influence on readings sent to communication or to memory.

### CT connection

If this setting is set to REVERSED it has the same influence as if CT's would be reversely connected. All power readings will also change its sign.

---

## Serial communication

### Serial Communication (COM1)

**Communication parameters** (only for COM1): Parameters which are important for the operation in RS485 network or connections with PC via RS232 communication. Factory settings of communication are #33\115200,n,8,2 (address 1 to 247\rate 2400 to 115200 b/s, parity, data bits, stop bit).



Main menu ⇒ Settings ⇒ Communication ⇒

**Push Data Format** (XML-smart, XML-logic) \*: With this setting a required data format for sending data to receiver using PUSH communication mode is set. For more information about *PUSH communication mode and XML data format* see chapter 7 on page 62 and *Appendix D* on page 86.

**Push Response Time** \*: With this setting a maximum waiting time for acknowledgement of sent data in PUSH communication mode is set.

**Time synchronization** \*: Which type of communication is used for synchronization of time for PUSH communication mode purpose.

\* Setting comes in to consideration only if device is connected to MiSmart system via serial communication.

### 2nd Communication module (COM2)

Module is present for RS485 or RS232 communication on I/O 3/4 terminals.

Module settings define parameters which are important for the operation in RS485 network or connections with PC via RS232 communication. Factory settings of communication are #33/115200,n,8,2 (address 1 to 247/rate 2400 to 115200 b/s, parity, data bits, stop bit). By default, addresses of COM1 and COM2 are the same (#33). In this case, change of COM1 address sets COM2 to the same address. When COM1 and COM2 addresses are not equal, change of COM1 address has no influence on COM2 address. Change of COM2 address has no influence on COM1 address. Device can be connected to the same network using COM1 or COM2 (if available).

---

## USB communication

### USB Communication

Has no setting. Device is automatically recognized in Windows environment if device driver has been correctly installed. For more detailed information how to handle device with USB communication use Help section in MiQen software.

When connected to USB port all other connections to allowed TCP ports are blocked or limited, until it is released. Priority, when connected to this port, has PUSH functionality of the device.

# Ethernet communication

## Ethernet communication

**Device Address:** Device address is important when user is trying to connect to device via MiQen software. Usable range of addresses is from 1 to 247. Default address number is 33.

**IP address:** Communication interface should have a unique IP address in the Ethernet network. Two modes for assigning IP are possible:

*Fixed IP address:* In most installations a fixed IP address is required. A system provider usually defines IP addresses. An IP address should be within a valid IP range, unique for your network and in the same subnetwork as your PC.

*DHCP:* Automatic (dynamic) method of assigning IP addressed (DHCP) is used in most networks. If you are not sure if DHPC is used in your network, check it at your system provider.

**IP Hostname:** Nickname that is assigned to a device connected to a network and is used to identify the device in various forms of electronic communication. Hostnames may be simple names consisting of a single word or phrase, or they may be structured.

**Local Port:** The physical connector on a device enabling the connection to be made. Use a non-reserved port number from 1025 to 65535.

Important port numbers	Function
1 – 1024, 9999, 30718, 33333	Reserved numbers!!!
502	Standard MODBUS port – fixed
33333	UDP port used for Device Discovery Service

*Port 502:* Is standardized port to communicate with the device via MODBUS/TCP communication protocol and is fixed. Communication via this port allows multiple connections to the device. Communication over this port does not block any other traffic.

*Port 33333:* This UDP port is reserved for Discovery Service, a service run by MiQen software, to discover devices connected in to local Ethernet communication network.

*Other available Ports:* Other, allowed TCP ports, are acting as terminal port and when connected to it, it blocks all other connections until it is released.

Priority, when connected to this port, has PUSH functionality of the device.

Factory settings of Ethernet communication are:

IP Address	DHCP (automatically)
TCP Port (Terminal Port)	10001
Subnet Mask	255.255.255.0

**Subnet Mask:** is used to determine what subnet an IP address belongs to.

**Gateway Address:** Gateway (node) IP that serves as an access point to other network.

**NTP Server:** If Ethernet NTP synchronisation is selected in General/Time Synchronisation source setting, in this field IP of NTP server needs to be entered.



### PLEASE NOTE



If device is connected in MiSmart system and has synchronisation set to MiSmart server, NTP synchronisation should be disabled.



Main menu ⇒ Settings ⇒ Communication ⇒ (not all settings are supported via keyboard)

### PUSH communication settings

When PUSH communication mode is used, data can be send (pushed) to two different servers. Within this setting, all parameters relevant to used servers should be set, as well as data type for sent data, time synchronization source and server response time.

For more information about PUSH communication mode and XML *Data format* see chapter 12 on page 86 and *Appendix D* on page 86.

*Time synchronization*: One of defined servers TCP Link 1 or TCP Link 2 need to be selected in Push Data Clients sections to enable synchronization of the device with the server. Operation of synchronization is described in section 0 *PUSH communication mode* on page 62.



#### PLEASE NOTE



If device is synchronised to any of TCP Links, NTP synchronisation should be disabled.

**TCP Link 1 and TCP Link 2:** Here information such as IP address, IP Port, Data Format and response time are defined.

**IP address:** IP address of the server collecting data from devices.

**IP port:** IP port of the server collecting data from devices.

**Data Format:** For use of the device in MiSmart system, *XML - Smart* data format needs to be selected.

**Response Time (sec):** Here response time from the server needs to be set. For devices connected in communication network with slow communication speed, values over 10 seconds needs to be selected. If value lower than 10 second is selected, historical data from recorders are pushed immediately one after another. If value is higher than 10 seconds, automatic time delay length of 10% of set value is integrated between the sent packets.

## Display

### Display settings

A combination of setting of the contrast and back light defines visibility and legibility of a display. Display settings shall be defined in compliance with the conditions in which it will be monitored. Economizing mode switches off back light according to the set time of inactivity.

 Main menu ⇒ Settings ⇒ LCD ⇒ Contrast / Back light / Back light time off

### Demo cycling period

It defines time in seconds for each displayed screen of measurements on LCD.

 Main menu ⇒ Settings ⇒ LCD ⇒ Demo cycling period

### Settings of customized screens

For easier and faster survey of measurements that are important for the user, three settings of customized screens are available. Each customized screen displays three measurements. When setting customized screens the designations are displayed in shorter form, with up to 4 characters. For survey of all designations see chapter *Survey of supported measurements regarding Connection* on page 11.

Example:

Desired result:

Customized screen 1	Customized screen 2	Customized screen 3	Combined customized screen 4
Average ph. voltage	Total current	Power angle ( $U_1-I_1$ )	Average ph. voltage
Avg. ph. to ph. volts	Neutral current	Frequency	Avg. ph. to ph. volts
Voltage unbalance	Average current	THD of PA $I_1$	Voltage unbalance
-	-	-	Total current
-	-	-	Neutral current

Setting can be made only for 3 customized screens. 4<sup>th</sup> customized screen is showing 5 values, three from Customized screen 1 and first two from Customized screen 2.

Setting:

Main menu ⇒ Settings ⇒ LCD ⇒ Custom screen 1 / 2 / 3 / (4)

Customized screen 1

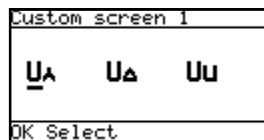

Customized screen 2

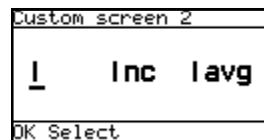

Customized screen 3

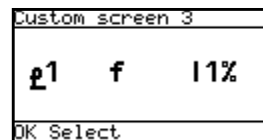

Main menu ⇒ Measurements ⇒ Present values ⇒ Custom OK

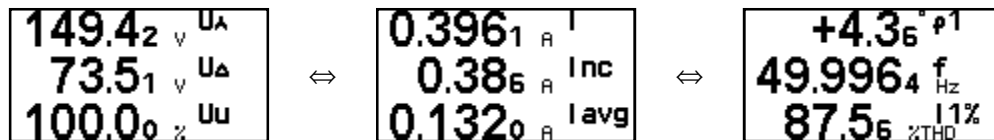

## Security

Settings parameters are divided into four groups regarding security level:

- At the lowest level (PL0), where a password is not required, parameters of LCD can be set: language, contrast and LCD back light.
- At the first level (PL1), settings of a real time clock can be changed, and energy meters (counters) and MD can be reset.
- At the second level (PL2), the access to all data that are protected with the first level (PL1) and setting of all other parameters in the »SETTINGS« menu are available.
- A backup password (BP) is used if passwords at levels 1 (PL1) and 2 (PL2) have been forgotten, and it is different for each device (depending on a serial number of the device). The BP password is available in the user support department in *ISKRA, d.d.*, and is entered instead of the password PL1 or/and PL2. Do not forget to state the devices' serial number when contacting the personnel in *ISKRA, d.d.*



### PLEASE NOTE



A serial number of device is stated on the label, LCD (see example below) and is also accessible with MiQen software.

The access to the device serial number via a keyboard

Example:

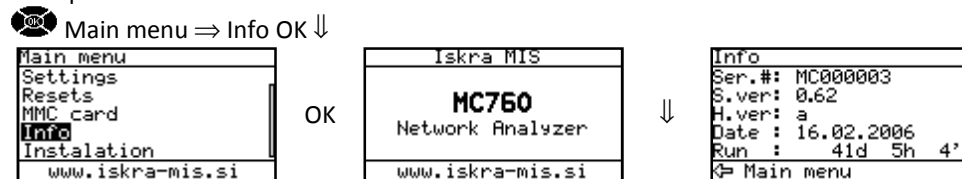

## Password setting

A password consists of four letters taken from the British alphabet from A to Z. When setting a password, only the letter being set is visible while the others are covered with \*.

A password of the first (L1) and the second (L2) level is entered, and time of automatic activation is set.

 Main menu ⇒ Settings ⇒ Security ⇒ Password level 1 / Password level 2 / Password lock time

## Password modification

A password is optionally modified; however, only that password can be modified to which the access is unlocked at the moment.

 Main menu ⇒ Settings ⇒ Security ⇒ Password level 1 / Password level 2

## Password disabling

A password is disabled by setting the "AAAA" password.

 Main menu ⇒ Settings ⇒ Security ⇒ Password level 1 / Password level 2 ⇒ "AAAA" OK

### PLEASE NOTE



A factory set password is "AAAA" at both access levels (L1 and L2). This password does not limit access.

## Password and language

Language change is possible without password input. When language is changed from or to Russian or Hebrew, character transformation has to be taken in to account. Character transformation table (English or Russian alphabet) is stated below.

English	A	B	C	D	E	F	G	H	I	J	K	L	M	N	O	P	Q	R	S	T	U	V	W	X	Y	Z
Russian	А	Б	В	Г	Д	Е	Ж	З	И	Й	К	Л	М	Н	О	П	Р	С	Т	У	Ф	Х	Ц	Ч	Ш	Щ

## Energy - counters

### WARNING!

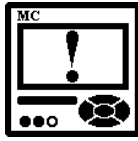

Before modification, all energy counters should be read or if energy values are stored in recorders, recorder should be read with MiQen software or stored on Memory card to assure data consistency for the past.

After modification of energy parameters, the energy meters (counters) should be reset. All recorded measurements from this point back might have wrong values so they should not be transferred to any system for data acquisition and analysis. Data stored before modification should be used for this purpose.

### Active tariff

When active tariff is set, one of the tariffs is defined as active; switching between tariffs is done either with a tariff clock or a tariff input. For the operation of the tariff clock other parameters of the tariff clock that are accessible only via communication or Memory card must be set correctly.

### Common Energy Counter Resolution

Common energy exponent defines minimal energy that can be displayed on the energy counter. On the basis of this and a counter divider, a basic calculation prefix for energy is defined (-3 is  $10^{-3}$ Wh = mWh, 4 is  $10^4$ Wh = 10 kWh). A common energy exponent also influences in setting a number of impulses for energy of pulse output or alarm output functioning as an energy meter.

Define common energy exponent as recommended in table below, where counter divider is at default value 10. Values of primary voltage and current determine proper Common energy exponent.

In MiQen setting software version 2.x and above, this setting parameter is renamed in Common Energy Counter Resolution. Also setting values are changed to give user better perspective of represented value.

In table below, new setting values are quoted in parenthesis.

Current Voltage	1 A	5 A	50 A	100 A	1000 A
110 V	-1 (100 mWh)	0 (1 Wh)	1 (10 Wh)	1 (10 Wh)	2 (100 Wh)
230 V	0 (1 Wh)	0 (1 Wh)	1 (10 Wh)	2 (100 Wh)	3 (1 kWh)
1000 V	0 (1 Wh)	1 (10 Wh)	2 (100 Wh)	3 (1 kWh)	4 (10 kWh)
30 kV	2 (100 Wh)	2 (100 Wh)	3 (1 kWh)	4 (10 kWh)	4* (10 kWh)

\* - Counter divider (MiQen 2.x and above - Individual Counter Resolution) should be at least 100

### Common energy cost exponent

Setting enables resolving the cost display. On the basis of this and a diving constant, a basic calculation prefix for energy cost is defined.

### Common tariff price exponent

Exponent and price represent energy price (active, reactive, common) in a tariff. The price exponent is used for recording the price without decimal places. For example, to set a price for tariff 1 to 0.1567 €/kWh, the number in Price for energy in tariff 1 field should be 1567 and common tariff price exponent should be -4 ( $1567 \times 1E-4 = 0.1567$ )

An example for 12.345kWh of consumed active energy in the first tariff (price 0.1567 €/kWh):

Common energy exponent	0	2	2
Counter divider	1	1	100
Common energy cost	-3	-2	0
Common tariff price exponent	-4	-4	-4
Price for energy in tariff 1	1567	1567	1567
Unit	EUR	EUR	EUR
Example of result, displayed	12.345 kWh	12.3 kWh	0.01 MWh

## LED Energy Counter

Connect energy counter activity to memory card LED on front panel of device. Select between Energy counter 1/2/3/4. Select Not set to disable this feature.

## LED Number of pulses

Define number of pulses per energy unit.

## LED Pulse length (ms)

Pulse duration for LED in milliseconds.

## Counters - Measured Energy

For each of four (4) counters different measured quantity can be selected. User can select from a range of predefined options referring to measured total energy or energy on single phase. Or can even select its own option by selecting appropriate quantity, quadrant, absolute or inverse function.

To energy counter also pulse / digital input can be attached. In this case Energy counter counts pulses from an outside source (water, gas, energy... meter).

## Counters - Individual counter Resolution

The counter divider additionally defines precision of a certain counter, according to settings of common energy exponent.

## Counters – Tariff Selector

Select tariffs where counter is active.

## Tariff clock

Basic characteristics of a program tariff clock:

- 4 tariffs (T1 to T4)
- Up to 4 time spots in each Day program for tariff switching
- Whichever combination of valid days in a week or holidays for each program
- Combining of day groups (use of over 4 time spots for certain days in a week)
- Separate settings for 4 seasons a year
- Up to 20 settable dates for holidays

### OPERATION OF INTERNAL TARIFF CLOCK

Tariff status is displayed in the Info menu.

Example of display for selected Active tariff:

Main menu ⇒ Info OK ↓ ↓ ↓ ⇒

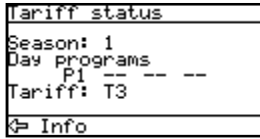

or

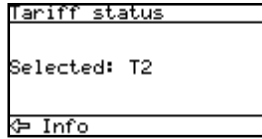

or



**Day program** sets up to 4 time spots (rules) for each day group in a season for tariff switching.

**A date of real time clock** defines an active period. An individual period is active from the period starting date to the first next date of the beginning of other periods.

The order of seasons and starting dates is not important, except when two dates are equal. In that case the season with a higher successive number has priority, while the season with a lower number will never be active.

If no starting date of a season is active, the active period is 1.

If the present date is before the first starting date of any period, the period is active with the last starting date.

Example of settings:

Season	Season start day
Season 1:	15.02
Season 2:	30.10
Season 3:	-
Season 4:	01.06
Date	Active season
01.01. - 14.02.	2 (last in the year)
15.02. - 31.05.	1
01.06. - 29.10.	4
30.10. - 31.12.	2

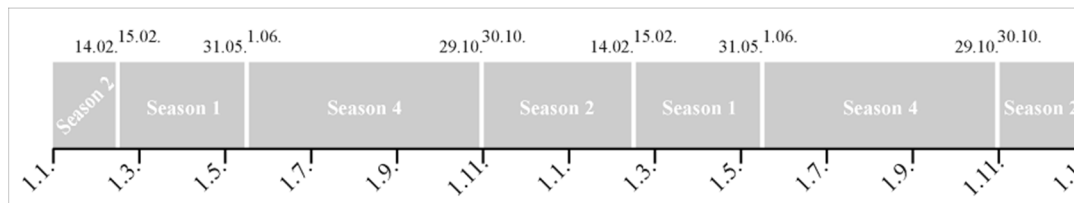

**Days in a week and selected dates for holidays** define time spots for each daily group in a period for tariff switching. Dates for holidays have priority over days in a week.

When the real time clock date is equal to one of a date of holidays, tariff is switched to holiday, within a period of active daily group with a selected holiday.

If there is no date of holidays that is equal to the real time clock date, all daily groups with the selected current day in a week are active.

Several daily groups can be active simultaneously, which enables more than 4 time spots in one day (combine of day programs). **If the time spot is not set for a certain day, tariff T1 is chosen.**

**Time of a real time clock** defines an active tariff regarding currently active day program. A selected tariff T1 to T4 of individual time spot is active from the time of the time spot to the first next time of the remaining time spots.

The order of time spots is not important, except when two times are equal. In that case the time with a higher successive number has priority (if several time spots are active, times of higher time spots have higher successive numbers), while the time spot with a lower number will never be active.

If current time is before the first time of any time spot of active spots, the time spot with the last time is chosen.

If no time spot of active programs is valid, tariff T1 is chosen.

Time selected tariff T1 to T4 or fixed selected tariff (via communication) defines activity of an energy counter.

---

## Inputs and outputs

MC750TH can be equipped with different I/O or communication modules. For its technical specifications see chapter *Technical data* on page 64.

For I/O 1 and 2 following options are available.

**Inputs:** There are seven main different input modules.

- DC current analogue input
- DC voltage analogue input
- Resistance (temperature) analogue input
- Pulse input
- Digital input
- Tariff input

Tariff and digital input can be ordered as three different hardware types with different voltage level, but the same functionality.

**Outputs:** There are five main different output modules.

- Analogue output
- Pulse output (solid state)
- Relay output (relay)
- Bistable alarm output (bistable relay)
- Watchdog (status) output

All modules have double input or output, except for a Bistable alarm output module, Watchdog output module and secondary communication module. All modules with a double input or output are in MiQen software presented as two separate modules.

An alarm output and a pulse output can also be selected via a keyboard. When selecting settings of energy and quadrants for a certain counter, only present selection is possible, while more demanding settings are accessible via communication. For other modules, information on a built-in module is available via LCD.

**Communication modules:** There are two different communication modules.

- 2<sup>nd</sup> communication module (RS232 or RS485)
- Communication module for Analogue extender EX104

## Analogue input module

Three types of analogue inputs are suitable for acquisition of low voltage DC signals from different sensors. According to application requirements it is possible to order current, voltage or resistance (temperature) analogue input. They all use the same output terminals.

MiQen software allows setting an appropriate calculation factor, exponent and required unit for representation of primary measured value (temperature, pressure, flux ...)

Signals from Analogue input can also be stored in built-in memory of a device (see supported types in *Memory* section on page 43). They can also be included in alarm function (see chapter *Alarms* on page 42).

**DC CURRENT RANGE:**

Range setting allows bipolar  $\pm 20$  mA or  $\pm 2$  mA max. input value

**DC VOLTAGE RANGE:**

Range setting allows bipolar  $\pm 10$  V or  $\pm 1$  V max. input value

**RESISTANCE / TEMPERATURE RANGE:**

Range setting allows 2000  $\Omega$  or 200  $\Omega$  max. input value

It is also possible to choose temperature sensor (PT100 or PT1000) with direct translation into temperature (-200°C to +850°C). Since only two-wire connection is possible it is recommended that wire resistance is also set, when long leads are used.

**Pulse input module** 

Module has no setting. It is general purpose pulse counter from external meters (water, gas, heat ...). Its value can be assigned to any of four energy counters. See chapter *Energy* on page 35.

It can also be used as digital input and included in alarm function to monitor signals from different sensors (see chapter *Alarms* on page 42).

Pulse input module has only one hardware configuration (5...48 V DC).

**Digital input module** 

Module has no settings. General purpose is to collect digital signals from various devices, such as (intrusion detection relay, different digital signals in transformer station, industry ...). It is available in three different hardware versions.

It can also be included in alarm function (see chapter *Alarms* on page 42).

When used in DC mode it can also be used as Pulse counter (see functionality of Pulse input module above).

**Tariff input module**  

**TARIFF INPUT**

Has no setting. It operates by setting active tariff at a tariff input (see chapter *Tariff clock* on page 36). The device can have maximal one module with 2 tariff inputs only. With the combination of 2 tariff inputs maximal 4 tariffs can be selected.

**ACTIVE TARIFF SELECTION TABLE:**

Active tariff	Signal presence on tariff input	
	Input T1/T2	Input T3/T4
Tariff 1	0	0
Tariff 2	1	0
Tariff 3	0	1
Tariff 4	1	1

**Analogue output module**  

Analogue output module has defined output range 20 mA DC. Quantity and shape (up to 6 break points) of an analogue output can be assigned via MiQen software. For more information see Help section in MiQen software.

## Pulse output module

It is a solid state, optocoupler open collector switch. Its main intention is to be used as a pulse output for selected energy counter, but can also be used as an alarm or general purpose digital output.

For description of output functionality see chapter Functions of Digital output (Pulse and Relay) modules below.

## Alarm output module (Relay output module)

It is a relay switch. Its main intention is to be used as an alarm output, but can also be used as a pulse or general purpose digital output.

A parallel RC filter with time constant of at least 250  $\mu\text{s}$  ( $R \cdot C \geq 250 \mu\text{s}$ ) should be used in case of a sensitive pulse counter. RC filter attenuates relay transient signals.

For description of output functionality see chapter Functions of Digital output (Pulse and Relay) modules below.

## Watchdog and Relay output module

Watchdog and relay module is a combination of two functionalities. One output is used for Watchdog functionality, the other acts as a Relay output module.

The purpose of Watchdog relay is to detect potential malfunction of device or auxiliary power supply failure. This module can be set for normal operation (relay in close position) or for test purposes to open position (manual activation). After test module should be set back to normal operation.

For description of output functionality see chapter Functions of Digital output (Pulse and Relay) modules below.

## Bistable alarm output module

A Bistable alarm module is a relay type and keeps the condition at output in case of device power failure.

### ALARM OUTPUT

Reaction of Bistable alarm module is connected to Alarm groups. Multiple alarm groups can be attached to it and different signal shapes defined. For more information on how to define alarm groups, see chapter *Alarms* on page 42.

## Functions of Digital output (Pulse and Relay) modules

To Digital outputs, Pulse and Relay, different functions can be attached. All can be set with MiQen software.

### PULSE OUTPUT OF ENERGY COUNTER

A corresponding Energy counter can be defined to a digital output. A number of pulses per energy unit, pulse length, and a tariff set in which output is active are set.

#### WARNING!

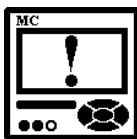

Pulse parameters are defined by EN 62053-31 standard. In chapter *Calculation of recommended pulse parameters*, below a simplified rule is described to assist you in setting the pulse output parameters.

 Main menu  $\Rightarrow$  Settings  $\Rightarrow$  Inputs/Outputs  $\Rightarrow$  I/O 1 / 2 / 3 / 4  $\Rightarrow$  Setting of pulse output OK

## CALCULATION OF RECOMMENDED PULSE PARAMETERS

Number of pulses per energy unit should be in certain limits according to expected power. If not so the measurement from pulse output can be incorrect. Settings of current and voltage transformers can help in estimation of expected power.

Principle described below for pulse setting, where e is prefix, satisfies EN 62053-31 standards pulse specifications:

1,5...15 eW → 100 p/1 eWh

Examples:

Expected power	→	Pulse output settings
150 - 1500 kW	→	1 p/1kWh
1,5 - 15 MW	→	100 p/1MWh
15 - 150 MW	→	10 p/1MWh
150 - 1500 MW	→	1 p/1MWh

## ALARM OUTPUT

If Digital output is defined as an Alarm output, its activity (trigger) is connected to Alarm groups. Multiple alarm groups can be attached to it and different signal shapes defined. For more information on how to define alarm groups, see chapter *Alarms* on page 42.



Main menu ⇒ Settings ⇒ Inputs/Outputs ⇒ V/I 1 / 2 / 3 / 4 ⇒ Setting of alarm output OK

### SIGNAL SHAPE:

- Normal - A relay is closed until condition for the alarm is fulfilled.
- Normal inverse - A relay is open until condition for the alarm is fulfilled.
- Holds - A relay is closed when condition for the alarm is fulfilled, and remains closed until it is reset via communication.
- Pulse - an impulse of the set length is sent always when condition for the alarm is fulfilled.
- Always switched on / off (permanent) - A relay is permanently switched on or switched off irrespective of the condition for the alarm.

Check an example in chapter *Alarms* on page 42 to have better perspective on alarm functionality.

User information

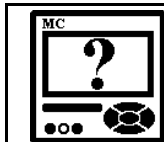

This possibility of permanent alarm setting enables remote control via communication.

## TARIFF OUTPUT

Digital output module can act also as a tariff clock output. Different tariffs can be defined to trigger relay. For tariff clock settings check chapter *Tariff clock* on page 36.

## 2nd Communication module (COM2)

Module is preset for RS232 or RS485 communication.

For other description see chapter *Serial communication* on page 30.

## Communication module for Analogue extender EX104

Module is preset for connection of up to 4 Analogue extender EX104 devices. It uses RS485 communication with fixed parameters to communicate with connected modules.

EX104 is a standalone unit with 4 programmable analogue outputs. Each connected unit needs to have unique device address (from 1 to 4).

For more detailed description of EX104 functionality and connection, check device technical documentation.

## Alarms

Alarms are used for alarming exceeded set values of the measured quantities.

Alarm condition can be set for any measured quantity, also for quantities measured on Analogue inputs or signals from Digital / Pulse input.

### WARNING!

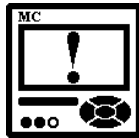

New values of alarms are calculated in percentage at modification of connection settings.

## Alarms setting

Measuring centre supports recording and storing of 32 alarms that are divided in to 4 groups of 8 alarms. For each group of alarms a time constant of maximal values in thermal mode, a delay time, alarm deactivation hysteresis and response time can be defined. For each separate alarm additional individual conditions can be set.

**MD Time constant:** Sets a time constant for thermal mode maximum demands for the alarm group.

**Compare time delay:** defines delay time between satisfying the alarm condition and alarm activation.

**Hysteresis:** defines alarm deactivation hysteresis.

**Response time:** defines alarm response on monitored quantity.

Normal response averaged measurements, according to display averaging settings (8 to 256 signal periods - see chapter *General settings / Average interval* on page 24) are used with this settings.

Fast response reacts on non-averaged measurements (1 signal period).

### INDIVIDUAL ALARM SETTINGS

For each individual alarm different settings are possible. It is possible to select:

**Parameter:** Quantity that would be monitored. Also selection of digital / pulse input from Digital input module 1 or 2 is possible if it is built in.

**Value:** current value or MD thermal function with time constant set in Alarm Group settings).

**Condition:** is a combination of a logical operator “Higher than” or “Lower than” and a limit value of the condition. For digital / pulse input it is possible to set condition is “Is high” or “Is low”.

**Action:** this section is equipped with checkboxes that applies different functions to individual alarms.

**Switch on Relay** checkbox can be selected if user wants this alarm to trigger output(s) that are connected to its group of alarms (pulse, relay or bistable output module). This action only applies to I/O modules 1 and 2. To relay outputs of I/O module A or B only single alarm can be attached. In this case Switch on Relay setting has no influence.

**Switch on sound signal** checkbox would activate built in beeper if this alarm is active.

**Alarm enabled** checkbox, activates alarm setting.

## Types of alarms

### VISUAL ALARM

When alarm is switched on, a red LED on the device front side is blinking (see figure shown on next page).

### AUDIBLE ALARM

When alarm is switched on, an audible alarm is given by the device (a beep). It can be switched off by pressing any key on the front plate (see figure shown on next page).

### ALARM OUTPUT (PULSE)

According to the alarm signal shape the output relay will behave as shown on next page.

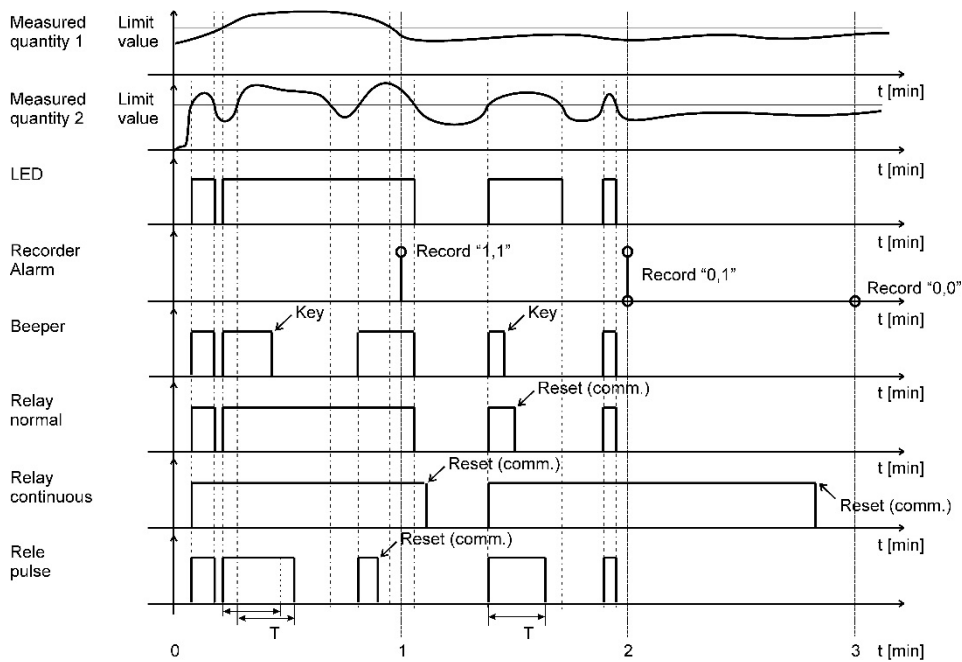

### Alarms PUSH functionality

When PUSH communication mode is active, all alarms can be sent (pushed) to a predefined location inside local or wide area network. Settings allow choosing an appropriate destination for data to be sent. Data are sent to the server immediately as alarms occur. If they cannot be sent immediately due to communication problems, they are sent at next alarm event (on or off) or data sending interval (whichever occurs first).

For more information see *PUSH Communication mode* on page 62.

## Memory

Measurements, alarms, reports and details of supply voltage quality are stored in a built in memory in the MC750TH 8MB flash. All records stored in memory are accessible via communication or memory card with MiQen software. Device also has a built in function that enables scheduled transmission of data, stored in memory, to MiSmart system. For more information regarding this check chapter *PUSH Communication mode* on page 62.

### Memory division

MMC memory is divided into 5 partitions which size is defined by the user. The A, B, C and D recorders are intended for recording measurements, while all alarms that occurred are recorded in an alarm partition.

## Memory operation

Memory functions in a cyclic mode in compliance with the FIFO method. This means that only the latest records are stored in the memory that will replace the oldest ones. A number of stored data or a storing period depends on selected partition size, a number of recorded quantities and time of division sampling. Occupancy of partitions is shown in the Information menu (see chapter *Display of device info* on page 32).

## Memory clearing

There is usually no need to clear the memory, because it works in cyclic mode. If you want to clear memory data anyway, the data storing must be stopped first. Read the device settings with MiQen and set “Recorder state” in Memory setting group to stopped. Download changes to the device and open Memory info form and then click on Clear memory button. Select memory partitions to be cleared on Memory clearing form and click on OK button. Set “Recorder state” setting back to active.

### WARNING!

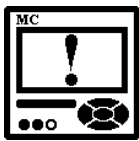

It is strongly advised to download recorder values before applying any changes to recorder or changes of settings for energy, type of connection, current and voltage transformer settings, used current and voltage ranges ...  
These changes might have impact on recorded history so data might no longer be valid.

## Recorders A, B, C and D setting

Recorders settings:

*Memory division:* Set desired size of memory partition for each recorder and alarms.

Recorder A/B/C/D/Alarm state: Start/stop recording.

*Recorder A/B/C/D mode:* Set function mode for recorder. Select between Standard recorder (32bit) or Standard recorder (16bit). Some things need to be taken in to consideration using one or another type.

Using **Standard recorder (16bit)**

- almost double amount of data can be stored compared to 32bit recorder
- support for PUSH functionality to MiSmart software
- data are stored in manufacturer defined formats (reconstruction depends on device setting)
- Energy counter resolution needs to be set correctly in order for Energy counter not to overflow; in this format differential value of a counter in recording period should not reach value of 20000; see table for correct Energy counter resolution setting in chapter Energy – counters on page 35

Using **Standard recorder (32bit)**

- smaller amount of data can be stored
- PUSH functionality to MiSmart software is not supported
- all data but Energy counters are stored in IEEE 754 Floating point format; Energy counters are stored in Signed Long integer format

Separately, for each of the recorders, settings can be set:

*Storage interval:* sets a time interval for readings to be written to a recorder

*MD Time constant:* sets a period for calculation of maximum and minimum value in thermal mode (Minimum (MD) or Maximum (MD)). Different parameter can be set for Recorded parameters 1-8 and 9-16.

*PUSH settings:* when PUSH communication mode is active, all measurements which are set to be written to the memory (max. 64 in all four recorders), can be sent (pushed) to a predefined location inside local or wide area network (from the time that PUSH functionality has been activated, not for the past records). Settings allow choosing an appropriate destination for data to be sent, time interval of sent data and a delay time for sending data if they cannot be sent immediately due to restrictions in network.

For more information see *PUSH Communication mode* on page 62.

*Recorded quantities:* for each of 16 measurements, which are to be recorded it is possible to set a required value and its representation within storage interval (min., max., avg. ...).

*Parameter:* here monitoring quantity can be selected from a list of supported measurements.

*Value:* representation of a value within set monitoring interval can be set to different conditions.

- Average value represents calculated average value
- Actual value represents value of recorded quantity at sampling intervals. (recommended for Pst and Plt measurements)
- Minimum and Maximum value represents minimum or maximum of recorded quantity in selected storage interval. Minimum or maximum in this case represents averaged value according to average interval selected in General settings (see page 24)
- Minimum (MD) and Maximum (MD) value represents calculation of a MD value with applied thermal function. Thermal function time constant is described above (MD Time constant).
- Minimum (Period) and Maximum (Period) value represents one period minimum or maximum of recorded quantity in selected storage interval.

## Reset operations

### Reset Min / Max values

All Min / Max values are reset.

 Main menu ⇒ Resets ⇒ Min/Max values ⇒

### Reset energy counters (E1, E2, E3, E4)

All or individual energy meters are reset.

 Main menu ⇒ Resets ⇒ Energy counters ⇒ All energy counters / Energy counter E1 / E2 / E3 / E4 OK

### Reset energy counters costs (E1, E2, E3, E4)

All or individual energy costs are reset.

 Main menu ⇒ Resets ⇒ Energy counters ⇒ All cost counters / Cost counter E1 / E2 / E3 / E4 OK

### Reset maximal MD values

#### THERMAL MODE

Current and stored MDs are reset.

#### FIXED INTERVAL / SLIDING WINDOWS

The values in the current time interval, in all sub-windows for sliding windows and stored MD are reset. In the same time, synchronization of time interval to the beginning of the first sub-window is also performed.

 Main menu ⇒ Resets ⇒ MD values ⇒

### Reset the last MD period

#### THERMAL MODE

Current MD value is reset.

#### FIXED INTERVAL / SLIDING WINDOWS

Values in the current time interval and in all sub-windows for sliding windows are reset. In the same time, synchronization of the time interval is also performed.

 Main menu ⇒ Resets ⇒ Last period MD ⇒

## MD synchronization

### THERMAL MODE

In this mode, synchronization does not have any influence.

### FIXED INTERVAL / SLIDING WINDOWS

Synchronization sets time in a period or a sub-period for sliding windows to 0 (zero). If the interval is set to 2, 3, 4, 5, 6, 10, 12, 15, 20, 30 or 60 minutes, time in a period is set to such value that some intervals will be terminated at completed hour.

Example:

 Main menu ⇒ Resets ⇒ Synchronize MD ⇒

Time constant (interval)	15 min	10 min	7 min
Synchronization start time	10:42	10:42	10:42
Time in a period	12 min	2 min	0 min
First final interval	10:45	10:50	10:49

## Alarm relay (1 or 2) Off

Turn off the alarm (relay output).

 Main menu ⇒ Resets ⇒ Reset alarm output ⇒

## Reset Min / Max values

All Min / Max values are reset.

 Main menu ⇒ Resets ⇒ Min/Max values ⇒

## Reset alarm statistic

Clears the alarm statistic. It can be made via MiQen software under Alarm settings.

---

## Settings and memory card

Measuring centre is provided with a built in slot for a full size MMC or SD memory card that is used for measurements transfer from internal memory, device setting and software upgrading. The memory card shall be formatted with the FAT16 file system.

### Supported memory cards

Measuring centre supports full size MMC memory card and MMC compatible SD memory card. Since not all SD card types are supported it is recommended to order it from *ISKRA, d.d.*

### Directory structure on memory card

A structure of directories is defined and enables correct data handling via a memory card. The memory card shall contain the following directories and files:

- DATA
- SETTING
- UPGRADE
- File: Automenu.txt (option)

## DATA

Records from the internal memory are collected in the DATA directory. To upload data of several devices to the memory card, each device checks and, if necessary, creates its own subdirectory before data transfer. Each subdirectory uses a devices' serial number as its name and stores files with data in it. Each file name contains date (year, month and day) and a record sequence number of that day.

### WARNING!

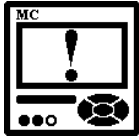

When uploading data file to memory card and there is a file with sequence number 99 of that day, a file with sequence number 00 is generated. File with sequence number 00 of that day, is overwritten in case of any further uploading data that day.

## SETTING

Settings are stored in the directory using two recording modes:

- With a type designation and a sequence number from 1 to 9
- With an device serial number

## UPGRADE

A file with upgrades is available for upload with the MiQen software. A file has a name of a corresponding device type designation and suffix fl2 (e.g. MC750TH.FL2).

## AUTOMENU.TXT

For faster and easier upgrading of the firmware there is »Automenu.txt« file in the root directory. When an memory card with a file is inserted and if upgrade version is higher, display automatically jumps into the memory card menu and suggests the Software upgrade menu, otherwise it automatically jumps into the Save data menu. When upgrading is finished and the OK key is pressed and memory card is removed, the menu that was displayed before inserting the memory card is displayed.

Automenu.txt file can be created by the user by means of the text editor. A new file has to be opened and saved under the correct name (Automenu.txt) and without content.

 Example:

```

DATA
↳   MC003973
    ↳   06050301.MC
    MC003974
    ↳   06050301.MC
        06070301.MC
    MC009424
    ↳   06060301.MC
        06070301.MC

SETTING
↳   MC003973.MSF
    MC760-1.MSF
    MC760-2.MSF
    MC750-1.MSF

UPGRADE
↳   MC760.FL2

Automenu.txt

```

## Handling memory card

Measuring centre is on the front panel equipped with a slot for a memory card. Slot is protected with a protection cover that can be simply removed before inserting the card. The protection cover shall be fixed back after the work is done.

**WARNING!**

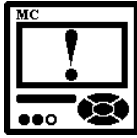

While memory card activity LED is pulsating memory card should not be touched or pulled out of the slot.

## Memory card information

Measuring centre checks a file system and capacity of the inserted memory card.

Main menu ⇒ MMC card ⇒ MMC info OK

## Save data

### SECTIONS

For each section define whether it is included for a record in a file.

### DATE

Since the last transfer, all available data from the last official reading with a password is included. For the Last week and the Last month, all data of the last complete unit (a week, a month) with the beginning in the first day at 00:00 is included. The selected date defines a day with the beginning at 00:00 from which further on to the current time of data transfer. When all data is selected, all data for an individual section, that are stored in the memory up to the moment when reading is started, are transferred.

### OFFICIAL READING

If official reading is selected date of reading is stored in device, and is applied at the next official reading.

Example:

Main menu ⇒ MMC card ⇒ Save data OK



**PLEASE NOTE**



Only active non-zero partitions are shown on Save data display.

## Save settings

File of current device settings are stored in SETTING directory. File name consists of device serial number and MSF extension. In case of file already stored on memory card, the device warns if file should be overwritten.

## Load settings

For loading settings, the files that correspond to the device type are displayed on LCD. When a file is selected, it is necessary to choose the segments of settings that will be overwritten. A number of registers that will be modified is written next to each segment. After settings transfer, a warning on errors could be displayed. Errors occur when the module setting and a memory capacity differ from the used ones in the device. A number of settings (registers) that do not match and are neither modified are displayed after warning.

### BASIC SETTINGS

At transfer of basic settings, settings of connections, ratios, used voltage and current ranges as well as nominal frequency are not changed. New settings can influence energy counters if recorded in a memory.

### ALARMS

Settings of all alarms are changed, but old alarms with previous settings remain in the memory.

### RECORDERS

Recorder overwriting enables modified setting of connection, ratio, used voltage and current ranges as well as nominal frequency. All other data in a memory is lost.

Example of a display on LCD for MC750TH:

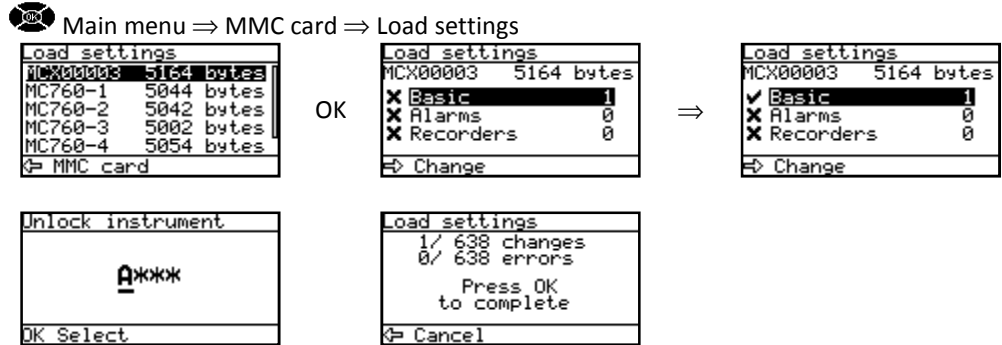

## Firmware upgrading

Before upgrading files on memory card are checked first, this can last some time (approx. 1 minute). When both versions are displayed, upgrade can be performed if the device software version is lower or equal to the version in a file.

**WARNING!**

When upgrading firmware software don't touch or pull out memory card and don't interrupt power supply - the device could become inoperative!  
Repairing of device in this case is to be done by authorized service.

Upgrade error codes:

- Error 1: memory card not inserted
- Error 2: Error on FAT16 file system
- Error 3: File not exist (.fl2)
- Error 4: Error in .fl2 file
- Error 5: File too long (.fl2)
- Error 6: Invalid file (.fl2)
- Error 7: Incorrect upgrade version (.fl2)

# MEASUREMENTS

## Introduction

In the following chapters operation of the device is explained more in detail.

## Available connections

Different electric connections are described more in detail in chapter *Electric connection* on page 13. Connections are marked as follows:

- Connection 1b (1Wb) – Single phase connection
- Connection 3b (1W3b) – Three phase, three wire connection with balanced load
- Connection 4b (1W4b) – Three phase, four wire connection with balanced load
- Connection 3u (2W3u) – Three phase, three wire connection with unbalanced load
- Connection 4u (3W4u) – Three phase, four wire connection with unbalanced load



PLEASE NOTE



Measurements support depends on connection mode and the device type.  
Calculated measurements are only informative.

## Survey of supported measurements regarding connection mode

All measurements, with designations can be displayed on customized screens.

	Basic measurements	Designat.	Unit	1b	3b	3u	4b	4u
Phase	Voltage $U_1$	U1	V	●	×	×	●	●
	Voltage $U_2$	U2	V	×	×	×	○	●
	Voltage $U_3$	U3	V	×	×	×	○	●
	Average voltage $U_{\sim}$	$U_{\Delta}$	V	×	×	×	○	●
	Current $I_1$	I1	A	●	●	●	●	●
	Current $I_2$	I2	A	×	○	●	○	●
	Current $I_3$	I3	A	×	○	●	○	●
	Calculated neutral current $I_n$	$I_{nc}$	A	×	○	○	○	●
	Total current $I_t$		A	●	○	○	○	●
	Average current $I_a$	$I_{avg}$	A	×	○	○	○	●
	Active power $P_1$	P1	W	●	×	×	●	●
	Active power $P_2$	P2	W	×	×	×	○	●
	Active power $P_3$	P3	W	×	×	×	○	●
	Total active power $P_t$	P	W	●	●	●	○	●
	Reactive power $Q_1$	Q1	var	●	×	×	●	●
	Reactive power $Q_2$	Q2	var	×	×	×	○	●
	Reactive power $Q_3$	Q3	var	×	×	×	○	●
	Total reactive power $Q_t$	Q	var	●	●	●	○	●
	Apparent power $S_1$	S1	VA	●	×	×	●	●
	Apparent power $S_2$	S2	VA	×	×	×	○	●

	Basic measurements	Designat.	Unit	1b	3b	3u	4b	4u
Phase	Apparent power $S_3$	S3	VA	×	×	×	○	●
	Total apparent power $S_t$	S	VA	●	●	●	○	●
	Power factor $PF_1$	PF1/ePF1		●	×	×	●	●
	Power factor $PF_2$	PF2/ePF2		×	×	×	○	●
	Power factor $PF_3$	PF3/ePF3		×	×	×	○	●
	Total power factor $PF^{\sim}$	PF/ePF		●	●	●	○	●
	Power angle $\phi_1$	$\phi_1$	°	●	×	×	●	●
	Power angle $\phi_2$	$\phi_2$	°	×	×	×	○	●
	Power angle $\phi_3$	$\phi_3$	°	×	×	×	○	●
	Total power angle $\phi^{\sim}$	$\phi$	°	●	●	●	○	●
	THD of phase voltage $U_{f1}$	U1%	%THD	●	×	×	●	●
	THD of phase voltage $U_{f2}$	U2%	%THD	×	×	×	○	●
	THD of phase voltage $U_{f3}$	U3%	%THD	×	×	×	○	●
	THD of phase current $I_1$	I1%	%THD	●	●	●	●	●
	THD of phase current $I_2$	I2%	%THD	×	○	●	○	●
THD of phase current $I_3$	I3%	%THD	×	○	●	○	●	
Phase-to-phase	Phase-to-phase voltage $U_{12}$	U12	V	×	●	●	○	●
	Phase-to-phase voltage $U_{23}$	U23	V	×	●	●	○	●
	Phase-to-phase voltage $U_{31}$	U31	V	×	●	●	○	●
	Average phase-to-phase voltage ( $U_{ff}$ )	$U_{\Delta}$	V	×	●	●	○	●
	Phase-to-phase angle $\phi_{12}$	$\phi_{12}$	°	×	×	×	○	●
	Phase-to-phase angle $\phi_{23}$	$\phi_{23}$	°	×	×	×	○	●
	Phase-to-phase angle $\phi_{31}$	$\phi_{31}$	°	×	×	×	○	●
	Voltage unbalance $U_u$	$U_u$	%	×	●	●	×	●
	THD of phase-to-phase voltage $THD_{U_{12}}$	U12%	%THD	×	●	●	○	●
	THD of phase-to-phase voltage $THD_{U_{23}}$	U23%	%THD	×	●	●	○	●
	THD of phase-to-phase voltage $THD_{U_{31}}$	U31%	%THD	×	●	●	○	●
Energy	Counters 1-4	E1,E2, E3,E4	Wh VAh varh	●	●	●	●	●
	Active tariff	Atar		●	●	●	●	●
	Cost by meters	E1\$,E2\$, E3\$,E4\$	XXXX	●	●	●	●	●
	Total cost	E\$	XXXX	●	●	●	●	●
Max. values MD	MD current $I_1$	I1	A	●	●	●	●	●
	MD current $I_2$	I2	A	×	○	●	○	●
	MD current $I_3$	I3	A	×	○	●	○	●
	MD active power P (positive)	P+	W	●	●	●	●	●
	MD active power P (negative)	P-	W	●	●	●	●	●
	MD reactive power Q-L	$Q_{\text{L}}$	var	●	●	●	●	●
	MD reactive power Q-C	$Q_{\text{C}}$	var	●	●	●	●	●
MD apparent power S	S	VA	●	●	●	●	●	

● - supported    ○ - calculated    × - not supported

**PLEASE NOTE**

Basic and MD measurements have designations for recognition via LCD. In this way they can be selected via LCD for a display on customized screens.

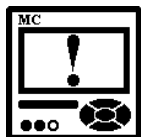
**WARNING!**

When, due to mode of connection, unsupported measurement is selected for customized screen an undefined value is displayed.

	Flicker measurement	Designat.	Unit	1b	3b	3u	4b	4u
Flickers Pst / Plt	Short term f. 1. phase voltage	Plt1		●	×	×	●	●
	Short term f. 2. phase voltage	Plt2		×	×	×	○	●
	Short term f. 3. phase voltage	Plt3		×	×	×	○	●
	Short term f. 1. Phase-to-phase voltage	Pst1		×	●	●	×	×
	Short term f. 2. phase-to-phase voltage	Pst2		×	●	●	×	×
	Short term f. 3. phase-to-phase voltage	Pst3		×	●	●	×	×
	Long term f. 1. phase voltage	Plt1		●	×	×	●	●
	Long term f. 2. phase voltage	Plt2		×	×	×	○	●
	Long term f. 3. phase voltage	Plt3		×	×	×	○	●
	Long term f. 1. phase-to-phase voltage	Pst1		×	●	●	×	×
	Long term f. 2. phase-to-phase voltage	Pst2		×	●	●	×	×
	Long term f. 3. phase-to-phase voltage	Pst3		×	●	●	×	×

● - supported    ○ - calculated    × - not supported

	Min/max measurements	1b	3b	3u	4b	4u
Instantaneous / Maximal / Minimal values	Voltage $U_1$	●	×	×	●	●
	Voltage $U_2$	×	×	×	○	●
	Voltage $U_3$	×	×	×	○	●
	Phase-to-phase voltage $U_{12}$	×	●	●	○	●
	Phase-to-phase voltage $U_{23}$	×	●	●	○	●
	Phase-to-phase voltage $U_{31}$	×	●	●	○	●
	Phase current $I_1$	●	●	●	●	●
	Phase current $I_2$	×	○	●	○	●
	Phase current $I_3$	×	○	●	○	●
	Active power $P_1$	●	×	×	●	●
	Active power $P_2$	×	×	×	○	●
	Active power $P_3$	×	×	×	○	●
	Total active power $P$	×	●	●	○	●
	Apparent power $S_1$	●	×	×	●	●
	Apparent power $S_2$	×	×	×	○	●
	Apparent power $S_3$	×	×	×	○	●
	Total apparent power $S$	×	●	●	○	●
Frequency $f$	●	●	●	●	●	
Internal temperature	●	●	●	●	●	

● - supported    ○ - calculated    × - not supported

	Measurements of harmonics	1b	3b	3u	4b	4u
Harmonics up to 63 <sup>rd</sup>	Phase voltage $U_1$	●	×	×	●	●
	Phase voltage $U_2$	×	×	×	○	●
	Phase voltage $U_3$	×	×	×	○	●
	Phase-to-phase voltage $U_{12}$	×	●	●	○	●
	Phase-to-phase voltage $U_{23}$	×	●	●	○	●
	Phase-to-phase voltage $U_{31}$	×	●	●	○	●
	Phase current $I_1$	●	●	●	●	●
	Phase current $I_2$	×	○	●	○	●
	Phase current $I_3$	×	○	●	○	●

● - supported   ○ - calculated   × - not supported

	Graphical display	1b	3b	3u	4b	4u
Time / FFT	Phase voltage $U_1$	●	×	×	●	●
	Phase voltage $U_2$	×	×	×	○	●
	Phase voltage $U_3$	×	×	×	○	●
	Phase-to-phase voltage $U_{12}$	×	●	●	○	●
	Phase-to-phase voltage $U_{23}$	×	●	●	○	●
	Phase-to-phase voltage $U_{31}$	×	●	●	○	●
	Phase current $I_1$	●	●	●	●	●
	Phase current $I_2$	×	○	●	○	●
	Phase current $I_3$	×	○	●	○	●

● - supported   ○ - calculated   × - not supported



#### PLEASE NOTE



For 3b and 3u connection mode, only phase to phase voltages are measured. Because of that factor  $\sqrt{3}$  is applied to calculation of quality considering nominal phase voltage. For 4u connection mode measurements support is same as for 1b.

## Explanation of basic concepts

### Sample factor – MV

A device measures all primary quantities with sample frequency which cannot exceed a certain number of samples in a time period. Based on these limitations (65 Hz·128 samples) a sample factor is calculated. A sample factor ( $M_V$ ), depending on frequency of a measured signal, defines a number of periods for a measurement calculation and thus a number of harmonics considered in calculations.

### Average interval – MP

Due to readability of measurements from LCD and via communication, an Average interval ( $M_P$ ) is calculated with regard to the measured signal frequency. The Average interval (see chapter *Average interval* on page 53) defines refresh rate of displayed measurements based on a sampling factor.

## Power and energy flow

Figures below show a flow of active power, reactive power and energy for 4u connection.

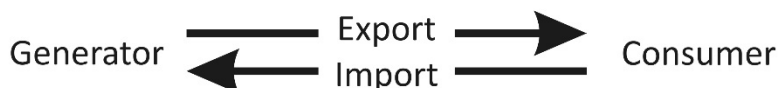
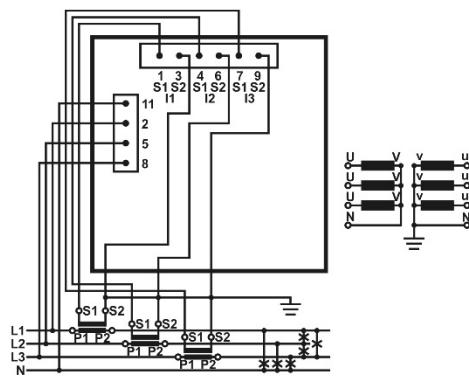
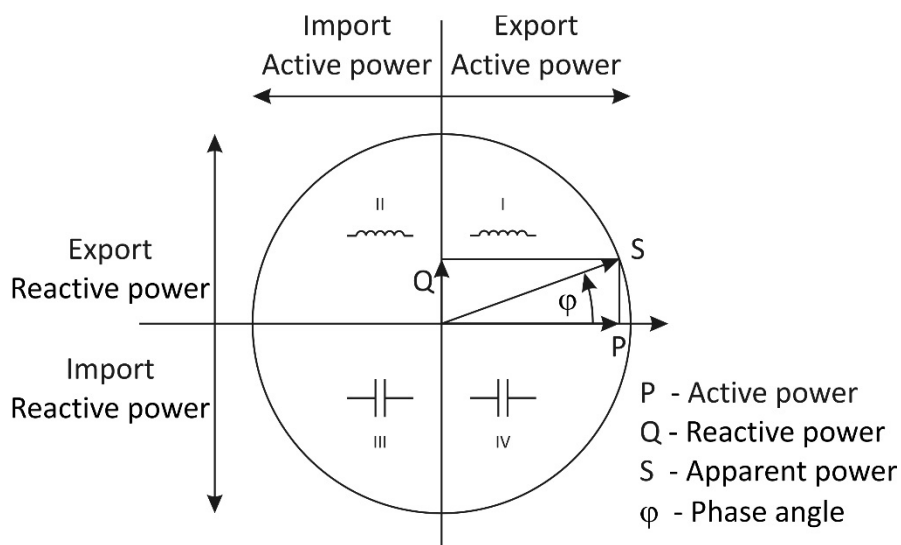

**PLEASE NOTE**

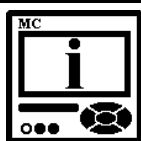

Display of energy flow direction can be adjusted to connection and operation requirements by changing the *Energy flow direction* settings in general / connection (see page 29).

## Calculation and display of measurements

This chapter deals with capture, calculation and display of all supported quantities of measurement. Only the most important equations are described; however, all of them are shown in chapter *Equations* on page 83 with additional descriptions and explanations.

PLEASE NOTE



Calculation and display of measurements depend on the device type and connection used. For more detailed information see *chapters Survey of supported measurements regarding connection mode* on page 50.

### Keyboard and display presentation

For entry and quitting measurement display menu, the OK key is used. Direction keys (left / right / up / down) are used for passing between displays as show in example below.

Example at 4u connection mode:

Main menu Main menu ⇒ Measurements ⇒ Present values ⇒ Voltage OK

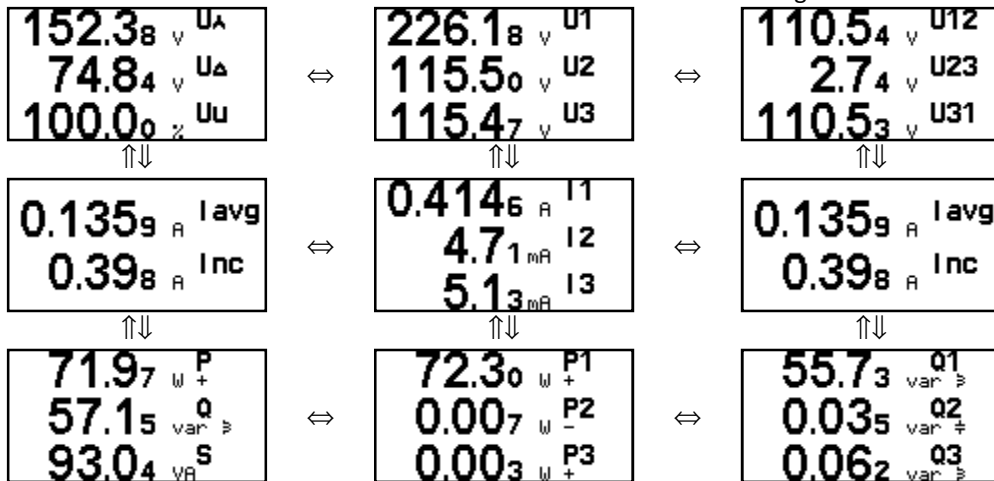

### Present values

PLEASE NOTE



Since measurement support depends on connection mode some display groups can be combined in to one, within Measurements menu.

### Voltage

The device measures real effective (rms) value of all phase voltages (U<sub>1</sub>, U<sub>2</sub>, U<sub>3</sub>), connected to it. Phase-to-phase voltages (U<sub>12</sub>, U<sub>23</sub>, U<sub>31</sub>), average phase voltage (U<sub>r</sub>) and average phase-to-phase voltage (U<sub>a</sub>) are calculated from measured phase voltages (U<sub>1</sub>, U<sub>2</sub>, U<sub>3</sub>). Voltage unbalance is calculated from phase-to-phase voltages (U<sub>12</sub>, U<sub>23</sub>, U<sub>31</sub>).

$$U_r = \sqrt{\frac{\sum_{n=1}^N U_n^2}{N}} \quad U_{xy} = \sqrt{\frac{\sum_{n=1}^N (u_{xn} - u_{yn})^2}{N}}$$

All voltage measurements are available via communication, serial and customized displays on LCD.

Main menu ⇒ Measurements ⇒ Present values ⇒ Voltage OK

## Current

The device measures real effective (rms) value of phase currents, connected to current inputs. Neutral current ( $I_n$ ), average current ( $I_a$ ) and a sum of all phase currents ( $I_i$ ) are calculated from phase currents.

$$I_{RMS} = \sqrt{\frac{\sum_{n=1}^N I_n^2}{N}}$$

All current measurements are available via communication, serial and customized displays on LCD.

Main menu  $\Rightarrow$  Measurements  $\Rightarrow$  Present values  $\Rightarrow$  Current OK

## Active, reactive and apparent power

Active power is calculated from instantaneous phase voltages and currents. All measurements are seen via communication or are displayed on LCD. For more detailed information about calculation see chapter *Equations* on page 83.

There are two different methods of calculating reactive power. See chapter *Reactive power and energy calculation* on page 28.

Main menu  $\Rightarrow$  Measurements  $\Rightarrow$  Present values  $\Rightarrow$  Power OK

## Power factor and power angle

Power angle is calculated as quotient of active and apparent power for each phase separately ( $\cos\varphi_1$ ,  $\cos\varphi_2$ ,  $\cos\varphi_3$ ) and total power angle ( $\cos\varphi_t$ ). A symbol for a coil represents inductive load and a symbol for a capacitor represents capacitive load. For correct display of PF via analogue output and application of the alarm, ePF (extended power factor) is applied. It illustrates power factor with one value as described in the table below. For a display on LCD both of them have equal display function: between -1 and -1 with the icon for inductive or capacitive load.

Load	C	$\rightarrow$		$\leftarrow$	L
Angle [°]	-180	-90	0	+90	+180 (179.99)
PF	-1	0	1	0	-1
ePF	-1	0	1	2	3

Example of analogue output for PF and ePF:

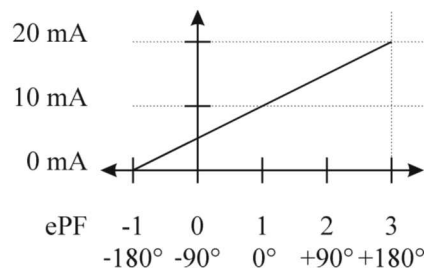
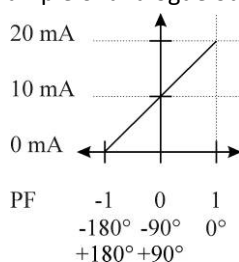

Power angle represents angle between first voltage harmonic and first current harmonic for each individual phase. Total power angle is calculated from total active and reactive power (see equation for Total power angle, chapter *Equations* on page 83). A positive sign shows inductive load, and a negative sign shows capacitive load.

Main menu  $\Rightarrow$  Measurements  $\Rightarrow$  Present values  $\Rightarrow$  PF & Power angle OK

## Frequency

Network frequency is calculated from time periods of measured voltage. Additionally frequency with 10-second averaging interval is displayed.

Main menu  $\Rightarrow$  Measurements  $\Rightarrow$  Present values  $\Rightarrow$  Frequency OK

## Energy - counters

Three ways of Energy - counters display are available: by individual counter, by tariffs for each counter separately and energy cost by counter. At a display of measured counter by tariffs, the sum in the upper line depends on the tariffs set in the device.

There are two different methods of calculating reactive energy. See chapter *Reactive power and energy calculation* on page 28.

Additional information, how to set and define a counter quantity is explained in chapter *ENERGY – counters* on page 35.

Example:

 Main menu ⇒ Measurements ⇒ Present values ⇒ Energy OK

## MD values

Display of MD values and time of recording (time stamp).

 Main menu ⇒ Measurements ⇒ Present values ⇒ MD values OK

## THD - Total harmonic distortion

THD is calculated for phase currents, phase and phase-to-phase voltages and is expressed as percent of high harmonic components regarding RMS value or relative to first harmonic (see chapter *Calculation of harmonics* on page 28).

Device uses measuring technique of real effective (rms) value that assures exact measurements with the presence of high harmonics up to 63rd harmonic.

 Main menu ⇒ Measurements ⇒ Present values ⇒ THD OK

## Flickers

Display of current Short term and Long term flickers for phase or phase-to-phase voltage (depending on mode of connection). Until the flicker value is calculated the symbol – is displayed.

 Main menu ⇒ Measurements ⇒ Present values ⇒ Flickers OK

## Customized screens

A display of customized screens depends on settings. See chapter *Settings of customized screens* on page 32.

 Main menu ⇒ Measurements ⇒ Present values ⇒ Custom OK

## Overview

It combines several measurements on each display as the following screens are displayed:

 Explanation of measurements at connection mode 4u:

### SCREEN 1:

Current phase measurements			Current phase measurements		
U <sub>λ</sub>	Average voltage U <sup>~</sup>	V	P	Total active power P <sub>t</sub>	W
1	Phase voltage U <sub>1</sub>	V	P1	Active power P <sub>1</sub>	W
2	Phase voltage U <sub>2</sub>	V	P2	Active power P <sub>2</sub>	W
3	Phase voltage U <sub>3</sub>	V	P3	Active power P <sub>3</sub>	W
I <sub>λ</sub>	Average current I <sup>~</sup>	A	Q	Total reactive power Q <sub>t</sub>	var
1	Current I <sub>1</sub>	A	Q1	Reactive power Q <sub>1</sub>	var
2	Current I <sub>2</sub>	A	Q2	Reactive power Q <sub>1</sub>	var
3	Current I <sub>3</sub>	A	Q3	Reactive power Q <sub>1</sub>	var

**SCREEN 2:**

Current phase-to-phase measurements			Current phase-to-phase measurements		
U $\Delta$	Average phase-to-phase U $\sim$	V		Frequency f	Hz
12	Phase-to-phase voltage U <sub>12</sub>	V	$\phi$	Power angle $\phi_1$	°
23	Phase-to-phase voltage U <sub>23</sub>	V	$\phi$	Power angle $\phi_2$	°
31	Phase-to-phase voltage U <sub>31</sub>	V	$\phi$	Power angle $\phi_3$	°
PF	Total power factor		$\phi$	Average phase-to-phase angle $\phi$	°
PF1	Power factor PF <sub>1</sub>		$\phi$	Power angle $\phi_{12}$	°
PF2	Power factor PF <sub>2</sub>		$\phi$	Power angle $\phi_{23}$	°
PF3	Power factor PF <sub>3</sub>		$\phi$	Power angle $\phi_1$	°

**SCREEN 3:**

Dynamic MD values			Maximal MD values		
P+	MD active power P (positive)	W		MD active power P (positive)	W
P-	MD active power P (negative)	W		MD active power P (negative)	W
Q $\ominus$	MD reactive power Q-L	var		MD reactive power Q-L	var
Q $\oplus$	MD reactive power Q-C	var		MD reactive power Q-C	var
S	MD apparent power S	VA		MD apparent power S	VA
I1	MD current I1	A		MD current I1	A
I2	MD current I2	A		MD current I2	A
I3	MD current I3	A		MD current I3	A

Example for MC750TH at connection 4u:

 Main menu  $\Rightarrow$  Measurements  $\Rightarrow$  Present values  $\Rightarrow$  Overview OK /  $\Rightarrow$ 

U $\Delta$	151.14 V	P	+78.00
U1	224.33 V	P1	+69.99
U2	114.57 V	P2	-0.003
U3	114.57 V	P3	+0.011
I $\Delta$	0.1362 A	Q	+55.91
I1	0.3992 A	Q1	+55.90
I2	4.63mA	Q2	-0.019
I3	5.11mA	Q3	+0.124



U $\Delta$	74.17 V	f	49.996 Hz
U1	109.90 V	$\phi$	-2.25°
U2	2.74 V	$\phi$	+0.03°
U3	109.87 V	$\phi$	+2.20°
I $\Delta$	+0.769L	$\phi$	+38.81°
I1	+0.779L	$\phi$	+3.67°
I2	+1.000L	$\phi$	-74.71°
I3	+1.000L	$\phi$	+65.57°



P+	64.933	4.4640kW
P-	0.000	6.562 W
Q $\ominus$	53.277	3.3265kvar
Q $\oplus$	0.000	14.994kvar
S	85.150	14.994kVA
I1	374.98m	10.012 A
I2	4.65m	10.007 A
I3	5.11m	10.007 A



## Min/Max values

All Min/Max values are displayed in the same way. Current values are displayed large in the middle of the screen, while minimal and maximal values are displayed smaller above and below the current values. Next to the current value is also measurement designation (see chapter *Survey of supported measurements regarding Connection* on page 17)

### Phase voltage Min/Max

Display of phase voltages  $U_1$ ,  $U_2$  and  $U_3$ .

 Main menu  $\Rightarrow$  Measurements  $\Rightarrow$  Min/Max values  $\Rightarrow$  Phase voltage OK

Phase-to-phase voltage  

Display of phase-to-phase voltages  $U_{12}$ ,  $U_{23}$  and  $U_{13}$ .

 Main menu  $\Rightarrow$  Measurements  $\Rightarrow$  Min/Max values  $\Rightarrow$  Phase to Phase voltage OK

### Current Min/Max

Display of currents  $I_1$ ,  $I_2$  and  $I_3$ .

 Main menu  $\Rightarrow$  Measurements  $\Rightarrow$  Min/Max values  $\Rightarrow$  Current OK

### Active power Min/Max

Display of active power  $P_1$ ,  $P_2$ ,  $P_3$  and  $P_t$ .

 Main menu  $\Rightarrow$  Measurements  $\Rightarrow$  Min/Max values  $\Rightarrow$  Active power OK

### Apparent power Min/Max

Display of apparent power  $S_1$ ,  $S_2$ ,  $S_3$  and  $S_t$ .

 Main menu  $\Rightarrow$  Measurements  $\Rightarrow$  Min/Max values  $\Rightarrow$  Apparent power OK

### Frequency Min/Max

Display of current frequency ( $f$ ) and frequency with 10-second averaging

 Main menu  $\Rightarrow$  Measurements  $\Rightarrow$  Min/Max values  $\Rightarrow$  Frequency OK

### Date and time of reset Min/Max

Display of date and time of the last reset and possibility of resetting Min/Max values.

 Main menu  $\Rightarrow$  Measurements  $\Rightarrow$  Min/Max values  $\Rightarrow$  Date and time of reset OK

## Alarms

An alarm menu enables surveying state of alarms. In the basic alarm menu, groups of alarms with the states of individual alarms and data on alarm outputs are displayed in the bottom line. For each active alarm a number of an alarm is written in a certain group at a certain place: Group 1: 1...45...8. Dot stands for alarm not active.

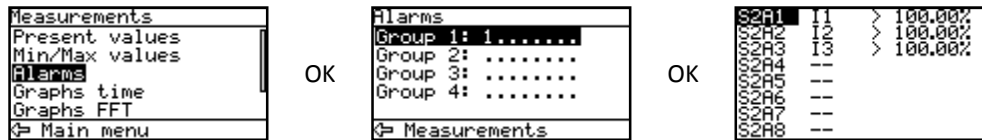

## Survey of alarms

In a detailed survey alarms are collected in groups. A number of a group and alarm is stated in the first column, a measurement designation in the second, and a condition for alarm in the third one. Active alarm is marked.

 Main menu ⇒ Measurements ⇒ Alarms OK / ⇒

## Time graphical display (Graphs time)

All time graphs of measured signals are made in the same way. In the upper part of LCD there is a measurement designation that is followed by a pea-to-peak signal value, and on the extreme right there is RMS value. In the central part of LCD a signal shape is drawn. For a better survey of the measured signal a scale is automatically adapted to the peak-to-peak signal value.

Example:

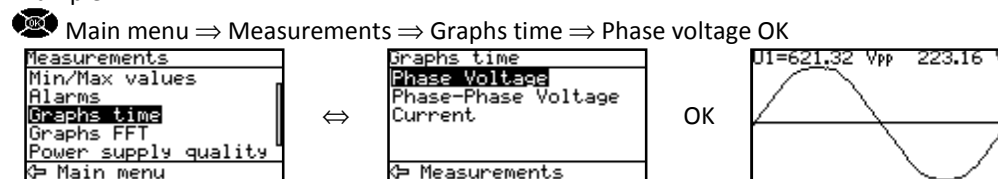

## Phase voltage

Display of time flow of voltage signals  $U_1$ ,  $U_2$  and  $U_3$ .

 Main menu ⇒ Measurements ⇒ Time graphs ⇒ Phase voltage OK / ⇒

## Phase-to-phase voltage

Display of time flow of phase-to-phase voltage signals  $U_{12}$ ,  $U_{23}$  and  $U_{31}$ .

 Main menu ⇒ Measurements ⇒ Time graphs ⇒ Phase-phase voltage OK / ⇒

## Current

Display of time flow of current signals  $I_1$ ,  $I_2$  and  $I_3$ .

 Main menu ⇒ Measurements ⇒ Time graphs ⇒ Current OK / ⇒

## FFT graphical display (Graphs FFT)

All FFT graphs of the measured signals are made in the same way. In the upper right angle of LCD the following measurements are stated:

- Designation of measurement with current RMS value
- Value of first harmonic
- Current frequency
- THD signal value

The remaining part is used for a (bar) graphic display of relative values of harmonics regarding the first one. For better resolution, first harmonic is not displayed and rating is automatically adapted according to highest harmonic values.

Example:

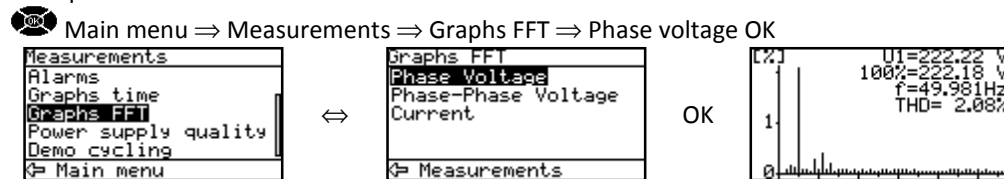

### Phase voltage

Display of harmonics of phase voltage signals  $U_1$ ,  $U_2$  and  $U_3$ .

 Main menu ⇒ Measurements ⇒ Time FFT ⇒ Phase voltage OK / ⇒

### Phase-to-phase voltage

Display of harmonics phase-to-phase voltage signals  $U_{12}$ ,  $U_{23}$  and  $U_{31}$ .

 Main menu ⇒ Measurements ⇒ Time FFT ⇒ Phase-phase voltage OK / ⇒

### Current

Display of harmonics of current signals  $I_1$ ,  $I_2$  and  $I_3$ .

 Main menu ⇒ Measurements ⇒ Time FFT ⇒ Current OK / ⇒

### Demo cycling

Regarding the period that is defined in settings, measurement screen cycling is started until any key is pressed.

 Main menu ⇒ Measurements ⇒ Demo cycling OK

---

# COMMUNICATION MODES

MC750 TH Network Recorder in general supports two different communication modes to suit all demands about connectivity and flexibility.

---

## PULL communication mode

This is most commonly used communication mode. It services data-on-demand and is therefore suitable for direct connection of setting and / or supervising software to a single device or for a network connection of multiple devices, which requires setting up an appropriate communication infrastructure.

Data is sent from device when it is asked by external software according to MODBUS RTU or MODBUS TCP protocol.

This type of communication is normally used for a real-time on-demand measurement collection for control purposes.

To set up PULL communication mode, only basic communication settings are required according to communication type (serial, USB, ETHERNET). See chapter *Communication* on page 11.

---

## PUSH communication mode

PUSH communication mode is mainly used in ISKRA, d.d. MiSmart system for remote monitoring, analysis and reporting.

### Explanation

When in this communication mode, the device (master) is sending values of predefined quantities in predefined time intervals to two independent servers (data collectors - slave), who collect data into data base for further analysis.

This mode of communication is very useful for a periodic monitoring of readings in systems where real-time data are not required, but on the other side, reliability for collecting data is essential (e.g. for billing purposes, post processing and issuing trend warnings).

On the other hand, when operating in this mode, the device will send information about alarms immediately as they occur (real time alarm monitoring).

This type of communication also optimizes communication traffic.

### Protocol and data format

Device uses XML format to send the data, which is very common and easy to use also for third party software solutions. Protocol used for data transmission is TCP/IP.

All sent readings are time-stamped for accurate reconstruction of received data (if communication is lost and data is sent afterwards). Therefore time synchronization of client and server is essential. For that purpose, server sends synchronization data packet to the device (for *Setting / Ethernet communication* see page 31) within every response to received data. If time difference is higher than +/- 2s, device resets its internal clock. For more information about used XML format see *Appendix D* on page 86.

## Data transmission

Every transmission from master side (device) must be acknowledged from client side (server) to verify successful data transmission. In case client fails to receive acknowledgment after predefined response time (for Setting / Ethernet communication see page 31) it will retry to send it in next time interval. This repeating of sending data will last until master responds to sent data. After that, client will send all available data from the moment it lost response from the master.

It is possible for PULL and PUSH communication mode to be active at the same time. Both communication modes can be handled at the same time if PULL communication is made over 2<sup>nd</sup> Communication module or over Ethernet module through port reserved for communication over MODBUS communication protocol (port 502 see chapter *Settings / Ethernet communication* on page 31).

## Supported quantities and settings

Sending data in PUSH communication mode is closely related with storing measurements in a recorder. Device can send to the selected server(s) a block of measure quantities that are stored in memory. For each memory division (recorders A, B, C and D, alarms recorder and quality reports with details recorder) separate settings can be made.

**Step 1:** In MiQen software, menu general/communication, set proper *PUSH Communication settings* (see page 31), where time synchronization source, response time, data format and receiving servers parameters are defined.

**Step 2:** Define data (quantities) for recorder / transmission (see section *Memory* on page 43). For each part of the recorder select to which of the server(s) will data be sent. This setting can be made for Alarms, Recorders A, B, C and D, Electric Quality reports and Electric Quality details. Parameters that can be set for some parts of recorders are:

- *Push data link*, sets the link to the server(s) defined in communication settings (see page 31).
- *Pushing period*, which set how often data shall be sent to server. This can either at every new reading, or at predefined time intervals (hourly, daily, weekly). When one of those intervals is used all data recorded between two time intervals is sent.
- *Pushing time delay* sets a delay time according to regular transmission period. This is useful in some situations to avoid simultaneous transmissions of multiple devices. Transmission delay can be disabled or user defined.

More information about PUSH data transfer and MiSmart system for collecting of this data can be found on *ISKRA, d.d.* web page or in documentation about MiSmart system.

# TECHNICAL DATA

## Accuracy

Measured values	Range		Accuracy class *
RMS current ( $I_1, I_2, I_3, I_{avg}, I_n$ )	1 A 5 A		0.5
Maximum current	12.5 A		0.5
RMS phase Voltage ( $U_1, U_2, U_3, U_{avg}$ )	75 V <sub>L-N</sub> 120 V <sub>L-N</sub> 250 V <sub>L-N</sub> 500 V <sub>L-N</sub>		0.5
Maximum voltage	ANSI 300 V, DIN 600 V		0.5
RMS phase-to-phase voltage ( $U_{12}, U_{23}, U_{31}, U_{avg}$ )	120 V <sub>L-L</sub> 210 V <sub>L-L</sub> 400 V <sub>L-L</sub> 800 V <sub>L-L</sub>		0.5
Frequency (f) - actual	50 / 60Hz		0.02
Frequency (10 s average)	50 / 60 Hz		
Nominal frequency range	16...400 Hz		
Power angle ( $\phi$ )	-180 ... 0 ... 180°		0.5°
Power factor (PF)	-1 ... 0 ... +1 U = 50 ... 120 % $U_n$ I = 2 % ... 200 % $I_n$		1.0
THD	5...500 V 0...400 %		0.5
Active power	75 120	375 600	0.5
Reactive power	250 500	1250 2500	1
Apparent power	[W/var/VA] $I_n = 1$ A	[W/var/VA] $I_n = 5$ A	0.5
Active energy	EN 62053-22		Class 0.5S
Reactive energy	EN 62053-23		Class 2
Pulse output	EN 62053-31		Class A & B
Real time clock (RTC)	-		1 min/month (30 ppm)
Analogue output (internal supply)	0...20 mA		± 200 $\mu$ A

\* Accuracy is presented as percentage from range except when it is stated as an absolute value.

## Inputs

Voltage input	Nominal voltage ( $U_n$ )	240 $V_{L-N}$
	Rating	75 $V_{L-N}$ / 120 $V_{L-N}$ / 250 $V_{L-N}$ / 500 $V_{L-N}$
	Overload	1.2 x $U_n$ permanently
	Minimal measurement	2 V sinusoidal
	Maximal measurement	600 $V_{L-N}$
	Consumption	< 0.1 VA per phase
Current input	Nominal current ( $I_n$ )	5 A
	Rating	1 A / 5 A
	Overload	3 x $I_n$ permanently, 25 x $I_n$ - 3 s, 50 x $I_n$ - 1 s
	Minimal measurement	Settings from starting current for all powers
	Maximal measurement	12.5 A sinusoidal
	Consumption	< 0.1 VA per phase
Frequency	Nominal frequency ( $f_n$ )	50, 60 Hz
	Measuring range	16 ... 400 Hz
	Maximum range	10 Hz ... 1 kHz
Supply Universal	AC voltage range	48 ... 276 V
	AC frequency range	40 ... 70 Hz
	DC voltage range	20 ... 300 V
	Consumption	< 12 VA
AC (DIN case only)	Voltage range	57.7 / 63.5 / 100 / 110 / 230 / 400 / 460 / 500 V
	Frequency range	40 ... 65 Hz
	Consumption	< 8 VA

## Connection

Permitted conductor cross-sections

Terminals	Max. conductor cross-sections DIN / ANSI housing
Voltage inputs (4)	$\leq 2.5 \text{ mm}^2 / 0,05 \dots 2,5 \text{ mm}^2$ one conductor
Current inputs (3)	$\leq \varnothing 6 \text{ mm}$ one conductor with insulation
Supply (2)	$\leq 2.5 \text{ mm}^2 / 0,05 \dots 2,5 \text{ mm}^2$ one conductor
Modules (2 x 3)	$\leq 2.5 \text{ mm}^2 / 0,05 \dots 2,5 \text{ mm}^2$ one conductor

## Modules

Alarm (Relay) output module	No. of outputs	2
	Max. switching power	40 VA
Max. switching voltage AC	Max. switching voltage DC	35 V
	Max. switching current	1 A
Impulse	Impulse	Max. 4000 imp/hour Min. length 100 ms
	Signal shape	
Normal	Normal	Until the condition is fulfilled
	Impulse	Start at any new condition
Permanent	Permanent	Since condition
Bistable alarm output module	No. Of outputs	1
	Max. switching power	40 VA
Max. switching voltage AC	Max. switching voltage DC	35 V
	Max. switching current	1 A
Signal shape	Normal	Until the condition is fulfilled
	Impulse	Start at any new condition
Permanent	Permanent	Since condition
Alarm/Watchdog /Digital output module	Type	Relay switch
	Rated voltage	48 V AC/DC (+40% max)
Max. switching current	Contact resistance	≤ 100 mΩ (100 mA, 24V)
	Impulse	Max. 4000 imp/hour Min. length 100 ms
Signal shape	Normal	Until the condition is fulfilled
	Impulse	Start at any new condition
Permanent	Permanent	Since condition
Pulse output module	No. of outputs	2
	Pulse length	2 ... 1000 ms
Maximal voltage	Maximal current	30 mA
	Analogue output module	
No. of outputs	Maximal load	150 Ω
	Output range	0 ... 20 mA
Supply	Supply	Internal

Analogue input module															
DC current input	<table> <tr> <td>Nominal input range 1</td> <td>-20 ... 0 ... 20 mA (<math>\pm 20\%</math>)</td> </tr> <tr> <td>Nominal input range 2</td> <td>-2 ... 0 ... 2 mA (<math>\pm 20\%</math>)</td> </tr> <tr> <td>input resistance</td> <td>20 <math>\Omega</math></td> </tr> <tr> <td>accuracy</td> <td>0.5 % of range</td> </tr> <tr> <td>temperature drift</td> <td>0.1% / °C (for range 2 only)</td> </tr> <tr> <td>conversion resolution</td> <td>16 bit (sigma-delta)</td> </tr> <tr> <td>Analogue input mode</td> <td>internally referenced Single-ended</td> </tr> </table>	Nominal input range 1	-20 ... 0 ... 20 mA ( $\pm 20\%$ )	Nominal input range 2	-2 ... 0 ... 2 mA ( $\pm 20\%$ )	input resistance	20 $\Omega$	accuracy	0.5 % of range	temperature drift	0.1% / °C (for range 2 only)	conversion resolution	16 bit (sigma-delta)	Analogue input mode	internally referenced Single-ended
Nominal input range 1	-20 ... 0 ... 20 mA ( $\pm 20\%$ )														
Nominal input range 2	-2 ... 0 ... 2 mA ( $\pm 20\%$ )														
input resistance	20 $\Omega$														
accuracy	0.5 % of range														
temperature drift	0.1% / °C (for range 2 only)														
conversion resolution	16 bit (sigma-delta)														
Analogue input mode	internally referenced Single-ended														
DC voltage input	<table> <tr> <td>Nominal input range1</td> <td>-10 ... 0 ... 10 V (<math>\pm 20\%</math>)</td> </tr> <tr> <td>Nominal input range 2</td> <td>-1 ... 0 ... 1 V (<math>\pm 20\%</math>)</td> </tr> <tr> <td>input resistance</td> <td>100 k<math>\Omega</math></td> </tr> <tr> <td>accuracy</td> <td>0.5 % of range</td> </tr> <tr> <td>temperature drift</td> <td>0.1% / °C (for range 2 only)</td> </tr> <tr> <td>conversion resolution</td> <td>16 bit (sigma-delta)</td> </tr> <tr> <td>Analogue input mode</td> <td>internally referenced Single-ended</td> </tr> </table>	Nominal input range1	-10 ... 0 ... 10 V ( $\pm 20\%$ )	Nominal input range 2	-1 ... 0 ... 1 V ( $\pm 20\%$ )	input resistance	100 k $\Omega$	accuracy	0.5 % of range	temperature drift	0.1% / °C (for range 2 only)	conversion resolution	16 bit (sigma-delta)	Analogue input mode	internally referenced Single-ended
Nominal input range1	-10 ... 0 ... 10 V ( $\pm 20\%$ )														
Nominal input range 2	-1 ... 0 ... 1 V ( $\pm 20\%$ )														
input resistance	100 k $\Omega$														
accuracy	0.5 % of range														
temperature drift	0.1% / °C (for range 2 only)														
conversion resolution	16 bit (sigma-delta)														
Analogue input mode	internally referenced Single-ended														
Resistance/ temperature Input module	<table> <tr> <td>Nominal input range (low)*</td> <td>0 - 200 <math>\Omega</math> (max. 400 <math>\Omega</math>) PT100 (-200°C–850°C)</td> </tr> <tr> <td>Nominal input range (high)*</td> <td>0 - 2 k<math>\Omega</math> (max. 4 k<math>\Omega</math>) PT1000 (-200°C- 850°C)</td> </tr> <tr> <td>connection</td> <td>2-wire</td> </tr> <tr> <td>accuracy</td> <td>0.5 % of range</td> </tr> <tr> <td>conversion resolution</td> <td>16 bit (sigma-delta)</td> </tr> <tr> <td>Analogue input mode</td> <td>internally referenced Single-ended</td> </tr> </table> <p>* Low or high input range and primary input value (resistance or temperature) are set by the MiQen setting software</p>	Nominal input range (low)*	0 - 200 $\Omega$ (max. 400 $\Omega$ ) PT100 (-200°C–850°C)	Nominal input range (high)*	0 - 2 k $\Omega$ (max. 4 k $\Omega$ ) PT1000 (-200°C- 850°C)	connection	2-wire	accuracy	0.5 % of range	conversion resolution	16 bit (sigma-delta)	Analogue input mode	internally referenced Single-ended		
Nominal input range (low)*	0 - 200 $\Omega$ (max. 400 $\Omega$ ) PT100 (-200°C–850°C)														
Nominal input range (high)*	0 - 2 k $\Omega$ (max. 4 k $\Omega$ ) PT1000 (-200°C- 850°C)														
connection	2-wire														
accuracy	0.5 % of range														
conversion resolution	16 bit (sigma-delta)														
Analogue input mode	internally referenced Single-ended														
Tariff input module	<table> <tr> <td>No. of inputs</td> <td>2</td> </tr> <tr> <td>Voltage</td> <td>5 ... 48 V DC *</td> </tr> <tr> <td></td> <td>110 <math>\pm 20\%</math> V AC/DC *</td> </tr> <tr> <td></td> <td>230 <math>\pm 20\%</math> V AC/DC *</td> </tr> </table> <p>* Depends on a built in hardware</p>	No. of inputs	2	Voltage	5 ... 48 V DC *		110 $\pm 20\%$ V AC/DC *		230 $\pm 20\%$ V AC/DC *						
No. of inputs	2														
Voltage	5 ... 48 V DC *														
	110 $\pm 20\%$ V AC/DC *														
	230 $\pm 20\%$ V AC/DC *														
Digital input module	<table> <tr> <td>No. of inputs</td> <td>2</td> </tr> <tr> <td>Voltage</td> <td>5 ... 48 V DC *</td> </tr> <tr> <td></td> <td>110 <math>\pm 20\%</math> V AC/DC *</td> </tr> <tr> <td></td> <td>230 <math>\pm 20\%</math> V AC/DC *</td> </tr> </table> <p>* Depends on built in hardware</p>	No. of inputs	2	Voltage	5 ... 48 V DC *		110 $\pm 20\%$ V AC/DC *		230 $\pm 20\%$ V AC/DC *						
No. of inputs	2														
Voltage	5 ... 48 V DC *														
	110 $\pm 20\%$ V AC/DC *														
	230 $\pm 20\%$ V AC/DC *														
Pulse input module	<table> <tr> <td>Rated voltage</td> <td>5 ... 48 V DC</td> </tr> <tr> <td>Max. Current</td> <td>8 mA (at 48 V DC) + 20%</td> </tr> <tr> <td>Min. pulse width</td> <td>0.5 ms</td> </tr> <tr> <td>Min. pulse period</td> <td>2 ms</td> </tr> <tr> <td>SET voltage</td> <td>40 ... 120 % of rated voltage</td> </tr> <tr> <td>RESET voltage</td> <td>0 ... 10 % of rated voltage</td> </tr> </table>	Rated voltage	5 ... 48 V DC	Max. Current	8 mA (at 48 V DC) + 20%	Min. pulse width	0.5 ms	Min. pulse period	2 ms	SET voltage	40 ... 120 % of rated voltage	RESET voltage	0 ... 10 % of rated voltage		
Rated voltage	5 ... 48 V DC														
Max. Current	8 mA (at 48 V DC) + 20%														
Min. pulse width	0.5 ms														
Min. pulse period	2 ms														
SET voltage	40 ... 120 % of rated voltage														
RESET voltage	0 ... 10 % of rated voltage														
2nd Comm. module (RS232 / RS485)	<table> <tr> <td>No. of communications</td> <td>1</td> </tr> <tr> <td>Type of connection</td> <td>Direct / Network</td> </tr> <tr> <td>Max. connection length</td> <td>3 m / 1000 m</td> </tr> </table>	No. of communications	1	Type of connection	Direct / Network	Max. connection length	3 m / 1000 m								
No. of communications	1														
Type of connection	Direct / Network														
Max. connection length	3 m / 1000 m														

## Communication

	Ethernet	RS485	RS232	USB
Type of connection	Network		Direct	
Max. conn. length	-	1000 m	3 m	5 m
Terminals	RJ-45	DB9 female connector or screw		USB-B type
Insulation	3.7 kV rms., 1 minute between terminals and other circuits			
Transfer mode	Asynchronous			
Protocol	MODBUS RTU / DNP3			
Transfer rate	10/100 Mb/s	2.400 to 115.200 bit/s		115.200 bit/s

## Electronic features

<b>LCD</b>		
Type	Graphic LCD	
Size	128 x 64 dots	
LCD refreshing	Every 200 ms	
<b>Response time</b>		
Input – screen	All calculations are averaged over an interval of between 8 to 256 periods. Present interval is 64 periods, which is 1.28 second at 50 Hz.	
Input – communication		
Input – relay		
<b>Memory</b>		
Capacity	8 Mb	
Divisions	Recorder A Recorder B Recorder C Recorder D Alarms recorder	
Selection of limit values	minimal maximal minimal (period) maximal (period) average actual minimal (thermal function) maximal (thermal function)	
Sampling period	1 to 60 min	
<b>LED's</b>		
Memory card	Red	Activity of memory card or LED energy counter
Communication	Green	Transmission of MC via communication
Alarm	Red	Fulfilled condition for alarm
<b>RTC backup supply</b>		
Battery	Lifespan	6 years (typical at 23°C)
Supercap	Lifespan	2 days

## Safety features

Safety	In compliance with <b>EN 61010-1</b>
	600 V rms, installation category II
	300 V rms, installation category III
	Pollution degree 2
Test voltage	3.7 kV rms, in compliance with <b>EN 61010-1</b>
EMC	Directive on electromagnetic compatibility 2004/108/EC
	In compliance with <b>EN 61326-1</b>
Protection	In compliance with <b>EN 60529</b>
	Front side (with protection cover for memory slot): IP52
	Rear side (with protection cover): IP20
Ambient conditions	
Climatic class	3
	In compliance with <b>EN 62052-11</b>
	In compliance with <b>EN 62052-21</b>
Temperature range of operation	-10 to +65°C
Storage temperature range	-40 to +70°C
Max. storage and transport humidity	≤ 75% r.h.
Enclosure	
DIN	PC/ABS, incombustibility - self-extinguishability, in compliance with UL 94 V0
Weight	AC up to 600g

## Dimensions

### Casing

Construction	Appearance
DIN	<p>All dimensions are in mm</p>

**Panel cut out**

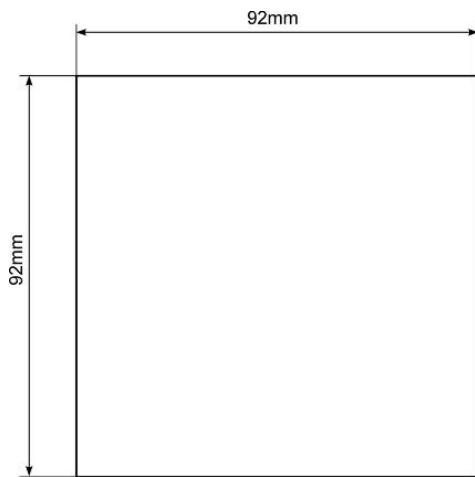

# APPENDIX A: MODBUS PROTOCOL

## Modbus communication protocol

Communication protocols:

Modbus and DNP3 protocol are enabled via RS232 and RS485 or Ethernet communication. Both communication protocols are supported on all communication ports of the device. The response is the same type as the request.

### Modbus

Modbus protocol enables operation of device on Modbus networks. For device with serial communication the Modbus protocol enables point to point (for example Device to PC) communication via RS232 communication and multi drop communication via RS485 communication. Modbus protocol is a widely supported open interconnect originally designed by Modicon.

The memory reference for input and holding registers is 30000 and 40000 respectively.

### Register table for the actual measurements

Parameter	MODBUS		
	Register		Type
	Start	End	
Voltage $U_1$	30107	30108	T5
Voltage $U_2$	30109	30110	T5
Voltage $U_3$	30111	30112	T5
Average phase Voltage $U_{\sim}$	30113	30114	T5
Phase to phase voltage $U_{12}$	30118	30119	T5
Phase to phase voltage $U_{23}$	30120	30121	T5
Phase to phase voltage $U_{31}$	30122	30123	T5
Average phase to phase Voltage $U_{pp\sim}$	30124	30125	T5
Current $I_1$	30126	30127	T5
Current $I_2$	30128	30129	T5
Current $I_3$	30130	30131	T5
Total Current I	30138	30139	T5
Neutral current $I_n$	30132	30133	T5
Real Power $P_1$	30142	30143	T6
Real Power $P_2$	30144	30145	T6
Real Power $P_3$	30146	30147	T6
Total Real Power P	30140	30141	T6
Reactive Power $Q_1$	30150	30151	T6
Reactive Power $Q_2$	30152	30153	T6
Reactive Power $Q_3$	30154	30155	T6
Total Reactive Power Q	30148	30149	T6
Apparent Power $S_1$	30158	30159	T5
Apparent Power $S_2$	30160	30161	T5
Apparent Power $S_3$	30162	30163	T5
Total Apparent Power S	30156	30157	T5
Power Factor $PF_1$	30166	30167	T7
Power Factor $PF_2$	30168	30169	T7
Power Factor $PF_3$	30170	30171	T7
Total Power Factor PF	30164	30165	T7
Power Angle $U_1-I_1$	30173		T2

Parameter	MODBUS		
	Register		Type
	Start	End	
Power Angle $U_2-I_2$	30174		T2
Power Angle $U_3-I_3$	30175		T2
Power Angle $\text{atan2}(P_t, Q_t)$	30172		T2
Angle $U_1-U_2$	30115		T2
Angle $U_2-U_3$	30116		T2
Angle $U_3-U_1$	30117		T2
Frequency $f$	30105	30106	T5
Voltage unbalance $U_u$	30176		T1
THD $I_1$	30188		T1
THD $I_2$	30189		T1
THD $I_3$	30190		T1
THD $U_1$	30182		T1
THD $U_2$	30183		T1
THD $U_3$	30184		T1
THD $U_{12}$	30185		T1
THD $U_{23}$	30186		T1
THD $U_{31}$	30187		T1
Max Demand Since Last RESET			
MD Real Power P (positive)	30542	30543	T6
MD Real Power P (negative)	30548	30549	T6
MD Reactive Power Q - L	30554	30555	T6
MD Reactive Power Q - C	30560	30561	T6
MD Apparent Power S	30536	30537	T5
MD Current $I_1$	30518	30519	T5
MD Current $I_2$	30524	30525	T5
MD Current $I_3$	30530	30531	T5
Dynamic Demand Values			
MD Real Power P (positive)	30510	30511	T6
MD Real Power P (negative)	30512	30513	T6
MD Reactive Power Q - L	30514	30515	T6
MD Reactive Power Q -	30516	30517	T6
MD Apparent Power S	30508	30509	T5
MD Current $I_1$	30502	30503	T5
MD Current $I_2$	30504	30505	T5
MD Current $I_3$	30506	30507	T5
Energy			
Energy Counter 1 Exponent	30401		T2
Energy Counter 2 Exponent	30402		T2
Energy Counter 3 Exponent	30403		T2
Energy Counter 4 Exponent	30404		T2
Counter E1	30406	30407	T3
Counter E2	30408	30409	T3
Counter E3	30410	30411	T3
Counter E4	30412	30413	T3
Counter E1, Cost	30446	30447	T3
Counter E2, Cost	30448	30449	T3
Counter E3, Cost	30450	30451	T3
Counter E4, Cost	30452	30453	T3
Active tariff	30405		T1
Internal Temperature	30181		T2

Actual counter value is calculated: Counter \* 10<sup>Exponent</sup>

## Register table for the normalized actual measurements (IEEE 754) Floating-Point Single Precision Value (32 bit)

Parameter	MODBUS		
	Register		Type
	Start	End	
Uavg (phase to neutral)	32484	32485	T_float
Uavg (phase to phase)	32486	32487	T_float
$\Sigma I$	32488	32489	T_float
Active Power Total (Pt)	32490	32491	T_float
Reactive Power Total (Qt)	32492	32493	T_float
Apparent Power Total (St)	32494	32495	T_float
Power Factor Total (PFt)	32496	32497	T_float
Frequency	32498	32499	T_float
U1	32500	32501	T_float
U2	32502	32503	T_float
U3	32504	32505	T_float
Uavg (phase to neutral)	32506	32507	T_float
U12	32508	32509	T_float
U23	32510	32511	T_float
U31	32512	32513	T_float
Uavg (phase to phase)	32514	32515	T_float
I1	32516	32517	T_float
I2	32518	32519	T_float
I3	32520	32521	T_float
I	32522	32523	T_float
I neutral (calculated)	32524	32525	T_float
I neutral (measured)	32526	32527	T_float
Iavg	32528	32529	T_float
Active Power Phase L1 (P1)	32530	32531	T_float
Active Power Phase L2 (P2)	32532	32533	T_float
Active Power Phase L3 (P3)	32534	32535	T_float
Active Power Total (Pt)	32536	32537	T_float
Reactive Power Phase L1 (Q1)	32538	32539	T_float
Reactive Power Phase L2 (Q2)	32540	32541	T_float
Reactive Power Phase L3 (Q3)	32542	32543	T_float
Reactive Power Total (Qt)	32544	32545	T_float
Apparent Power Phase L1 (S1)	32546	32547	T_float
Apparent Power Phase L2 (S2)	32548	32549	T_float
Apparent Power Phase L3 (S3)	32550	32551	T_float
Apparent Power Total (St)	32552	32553	T_float
Power Factor Phase 1 (PF1)	32554	32555	T_float
Power Factor Phase 2 (PF2)	32556	32557	T_float
Power Factor Phase 3 (PF3)	32558	32559	T_float
Power Factor Total (PFt)	32560	32561	T_float
CAP/IND P. F. Phase 1 (PF1)	32562	32563	T_float
CAP/IND P. F. Phase 2 (PF2)	32564	32565	T_float
CAP/IND P. F. Phase 3 (PF3)	32566	32567	T_float
CAP/IND P. F. Total (PFt)	32568	32569	T_float
$\varphi 1$ (angle between U1 and I1)	32570	32571	T_float
$\varphi 2$ (angle between U2 and I2)	32572	32573	T_float
$\varphi 3$ (angle between U3 and I3)	32574	32575	T_float

Parameter	MODBUS		
	Register		Type
	Start	End	
Power Angle Total (atan2(Pt,Qt))	32576	32577	T_float
φ12 (angle between U1 and U2)	32578	32579	T_float
φ23 (angle between U2 and U3)	32580	32581	T_float
φ31 (angle between U3 and U1)	32582	32583	T_float
Frequency	32584	32585	T_float
U unbalance	32586	32587	T_float
I1 THD%	32588	32589	T_float
I2 THD%	32590	32591	T_float
I3 THD%	32592	32593	T_float
U1 THD%	32594	32595	T_float
U2 THD%	32596	32597	T_float
U3 THD%	32598	32599	T_float
U12 THD%	32600	32601	T_float
U23 THD%	32602	32603	T_float
U31 THD%	32604	32605	T_float
Max Demand Since Last RESET			
Active Power Total (Pt) - (positive)	32606	32607	T_float
Active Power Total (Pt) - (negative)	32608	32609	T_float
Reactive Power Total (Qt) - L	32610	32611	T_float
Reactive Power Total (Qt) - C	32612	32613	T_float
Apparent Power Total (St)	32614	32615	T_float
I1	32616	32617	T_float
I2	32618	32619	T_float
I3	32620	32621	T_float
Dynamic Demand Values			
Active Power Total (Pt) - (positive)	32622	32623	T_float
Active Power Total (Pt) - (negative)	32624	32625	T_float
Reactive Power Total (Qt) - L	32626	32627	T_float
Reactive Power Total (Qt) - C	32628	32629	T_float
Apparent Power Total (St)	32630	32631	T_float
I1	32632	32633	T_float
I2	32634	32635	T_float
I3	32636	32637	T_float
Energy			
Energy Counter 1	32638	32639	T_float
Energy Counter 2	32640	32641	T_float
Energy Counter 3	32642	32643	T_float
Energy Counter 4	32644	32645	T_float
Energy Counter 1 Cost	32646	32647	T_float
Energy Counter 2 Cost	32648	32649	T_float
Energy Counter 3 Cost	32650	32651	T_float
Energy Counter 4 Cost	32652	32653	T_float
Total Energy Counter Cost	32654	32655	T_float
Active Tariff	32656	32657	T_float
Internal Temperature	32658	32659	T_float

## Register table for the normalized actual measurements

Parameter	MODBUS		100% value
	Register	Type	
Voltage $U_1$	30801	T16	Un
Voltage $U_2$	30802	T16	Un
Voltage $U_3$	30803	T16	Un
Average phase Voltage $U_{\sim}$	30804	T16	Un
Phase to phase voltage $U_{12}$	30805	T16	Un
Phase to phase voltage $U_{23}$	30806	T16	Un
Phase to phase voltage $U_{31}$	30807	T16	Un
Average phase to phase Voltage $U_{pp-}$	30808	T16	Un
Current $I_1$	30809	T16	In
Current $I_2$	30810	T16	In
Current $I_3$	30811	T16	In
Total Current I	30812	T16	It
Neutral current $I_n$	30813	T16	In
Average Current $I_{\sim}$	30815	T16	In
Real Power $P_1$	30816	T17	Pn
Real Power $P_2$	30817	T17	Pn
Real Power $P_3$	30818	T17	Pn
Total Real Power P	30819	T17	Pt
Reactive Power $Q_1$	30820	T17	Pn
Reactive Power $Q_2$	30821	T17	Pn
Reactive Power $Q_3$	30822	T17	Pn
Total Reactive Power Q	30823	T17	Pt
Apparent Power $S_1$	30824	T16	Pn
Apparent Power $S_2$	30825	T16	Pn
Apparent Power $S_3$	30826	T16	Pn
Total Apparent Power S	30827	T16	Pt
Power Factor $PF_1$	30828	T17	1
Power Factor $PF_2$	30829	T17	1
Power Factor $PF_3$	30830	T17	1
Total Power Factor PF	30831	T17	1
CAP/IND P.F. Phase 1 ( $PF_1$ )	30832	T17	1
CAP/IND P.F. Phase 2 ( $PF_2$ )	30833	T17	1
CAP/IND P.F. Phase 3 ( $PF_3$ )	30834	T17	1
CAP/IND P.F. Total (Pft)	30835	T17	1
Power Angle $U_1-I_1$	30836	T17	100°
Power Angle $U_2-I_2$	30837	T17	100°
Power Angle $U_3-I_3$	30838	T17	100°
Power Angle $\text{atan2}(Pt, Qt)$	30839	T17	100°
Angle $U_1-U_2$	30840	T17	100°
Angle $U_2-U_3$	30841	T17	100°
Angle $U_3-U_1$	30842	T17	100°
Frequency	30843	T17	$F_n+10\text{Hz}$
Voltage unbalance $U_u$	30844	T16	100%
THD $I_1$	30845	T16	100%
THD $I_2$	30846	T16	100%
THD $I_3$	30847	T16	100%
THD $U_1$	30848	T16	100%
THD $U_2$	30849	T16	100%
THD $U_3$	30850	T16	100%
THD $U_{12}$	30851	T16	100%
THD $U_{23}$	30852	T16	100%
THD $U_{31}$	30853	T16	100%

Parameter	MODBUS		100% value
	Register	Type	
Max Demand Since Last Reset			
MD Real Power P (positive)	30854	T16	Pt
MD Real Power P (negative)	30855	T16	Pt
MD Reactive Power Q – L	30856	T16	Pt
MD Reactive Power Q – C	30857	T16	Pt
MD Apparent Power S	30858	T16	Pt
MD Current I <sub>1</sub>	30859	T16	In
MD Current I <sub>2</sub>	30860	T16	In
MD Current I <sub>3</sub>	30861	T16	In
Dynamic Demand Values			
MD Real Power P (positive)	30862	T16	Pt
MD Real Power P (negative)	30863	T16	Pt
MD Reactive Power Q – L	30864	T16	Pt
MD Reactive Power Q – C	30865	T16	Pt
MD Apparent Power S	30866	T16	Pt
MD Current I <sub>1</sub>	30867	T16	In
MD Current I <sub>2</sub>	30868	T16	In
MD Current I <sub>3</sub>	30869	T16	In
Energy			
Energy Counter 1	30870	T17	Actual counter value MOD 20000 is returned
Energy Counter 2	30871	T17	
Energy Counter 3	30872	T17	
Energy Counter 4	30873	T17	
Energy Counter 1 Cost	30874	T17	
Energy Counter 2 Cost	30875	T17	
Energy Counter 3 Cost	30876	T17	
Energy Counter 4 Cost	30877	T17	
Total Energy Counter Cost	30878	T17	
Active Tariff	30879	T1	
Internal Temperature	30880	T17	100°
Frequency (wide range) 0.00 – 655.35 Hz	30891	T16	100 Hz

## 100% values calculations for normalized measurements

Un =	$(R40147 / R40146) * R30015 * R40149$
In =	$(R40145 / R40144) * R30017 * R40148$
Pn =	Un*In
It =	In      Connection Mode: 1b
It =	3*In      Connection Modes: 3b, 4b, 3u, 4u
Pt =	Pn      Connection Mode: 1b
Pt =	3*Pn      Connection Modes: 3b, 4b, 3u, 4u
Fn =	R40150

All other MODBUS registers are a subject to change. For the latest MODBUS register definitions go to ISKRA d.d. web page <http://www.iskra.si/>

Register	Content
30015	Calibration voltage
30017	Calibration current

## Register table for the basic settings

Register	Content	Type	Ind	Values / Dependencies	Min	Max	P. Level
40143	Connection Mode	T1	0	No mode	1	5	2
			1	1b - Single Phase			
			2	3b - 3 phase 3 wire			
			3	4b - 3 phase 4 wire			
			4	3u - 3 phase 3 wire			
			5	4u - 3 phase 4 wire			
40144	CT Secondary	T4		mA			2
40145	CT Primary	T4		A/10			2
40146	VT Secondary	T4		mV			2
40147	VT Primary	T4		V/10			2
40148	Current input range (%)	T16		10000 for 100%	5.00	200.00	2
40149	Voltage input range (%)	T16		10000 for 100%	2.50	100.00	2
40150	Frequency nominal	T1		Hz	10	1000	2

## Data types decoding

Type	Bit mask	Description
T1		Unsigned Value (16 bit) Example: 12345 = 3039(16)
T2		Signed Value (16 bit) Example: -12345 = CFC7(16)
T3		Signed Long Value (32 bit) Example: 123456789 = 075B CD 15(16)
T4	bits # 15...14 bits # 13...00	Short Unsigned float (16 bit) Decade Exponent(Unsigned 2 bit) Binary Unsigned Value (14 bit) Example: 10000*102 = A710(16)
T5	bits # 31...24 bits # 23...00	Unsigned Measurement (32 bit) Decade Exponent(Signed 8 bit) Binary Unsigned Value (24 bit) Example: 123456*10 <sup>-3</sup> = FD01 E240(16)
T6	bits # 31...24 bits # 23...00	Signed Measurement (32 bit) Decade Exponent (Signed 8 bit) Binary Signed value (24 bit) Example: - 123456*10 <sup>-3</sup> = FDFE 1DC0(16)
T7	bits # 31...24 bits # 23...16 bits # 15...00	Power Factor (32 bit) Sign: Import/Export (00/FF) Sign: Inductive/Capacitive (00/FF) Unsigned Value (16 bit), 4 decimal places Example: 0.9876 CAP = 00FF 2694(16)
T9	bits # 31...24 bits # 23...16 bits # 15...08 bits # 07...00	Time (32 bit) 1/100s 00 - 99 (BCD) Seconds 00 - 59 (BCD) Minutes 00 - 59 (BCD) Hours 00 - 24 (BCD) Example: 15:42:03.75 = 7503 4215(16)
T10	bits # 31...24 bits # 23...16 bits # 15...00	Date (32 bit) Day of month 01 - 31 (BCD) Month of year 01 - 12 (BCD) Year (unsigned integer) 1998..4095 Example: 10, SEP 2000 = 1009 07D0(16)
T16		Unsigned Value (16 bit), 2 decimal places Example: 123.45 = 3039(16)
T17		Signed Value (16 bit), 2 decimal places Example: -123.45 = CFC7(16)
T_float	bits # 31 bits # 31 bits # 31	IEEE 754 Floating-Point Single Precision Value (32bit) Sign Bit (1 bit) Exponent Field (8 bit) Significant (23 bit) Example: 123.45 stored as 123.45000 = 42F6 E666(16)
T_Str4		<b>Text:</b> 4 characters (2 characters for 16 bit register)
T_Str6		<b>Text:</b> 6 characters (2 characters for 16 bit register)
T_Str8		<b>Text:</b> 8 characters (2 characters for 16 bit register)
T_Str16		<b>Text:</b> 16 characters (2 characters for 16 bit register)
T_Str40		<b>Text:</b> 40 characters (2 characters for 16 bit register)

# APPENDIX B: DNP3 PROTOCOL

## DNP3 communication protocol

Communication protocols:

Modbus and DNP3 protocol are enabled via RS232 and RS485 or Ethernet communication. Both communication protocols are supported on all communication ports of the device. The response is the same type as the request.

### DNP3

DNP3 protocol enables operation of MC on DNP3 networks. For device with serial communication the DNP3 protocol enables point to point (for example device to PC) communication via RS232 communication and multi drop communication via RS485.

Object			Request		Response	
Object Number	Variation Number	Description	Function Codes (dec)	Qualifier Codes (hex)	Function Codes (dec)	Qualifier Codes (hex)
30	2	16-Bit Analogue Input with flag	1	00, 01, 02, 06	129	00, 01, 02, 00
30	4	16-Bit Analogue Input without flag	1	00, 01, 02, 06	129	00, 01, 02, 00

### Register table for the actual measurements

DNP3 Point	Parameter	Type	100% value
0	Voltage U1	T16	Un
1	Voltage U2	T16	Un
2	Voltage U3	T16	Un
3	Average phase Voltage U~	T16	Un
4	Phase to phase voltage U12	T16	Un
5	Phase to phase voltage U23	T16	Un
6	Phase to phase voltage U31	T16	Un
7	Average phase to phase Voltage Upp~	T16	Un
8	Current I1	T16	In
9	Current I2	T16	In
10	Current I3	T16	In
11	Total Current I	T16	In
12	Neutral current In	T16	In
13	Reserved	T16	In
14	Average Current I~	T16	In
15	Real Power P1	T17	Pn
16	Real Power P2	T17	Pn
17	Real Power P3	T17	Pn
18	Total Real Power P	T17	Pt
19	Reactive Power Q1	T17	Pn
20	Reactive Power Q2	T17	Pn
21	Reactive Power Q3	T17	Pn

DNP3 Point	Parameter	Type	100% value
22	Total Reactive Power Q	T17	Pt
23	Apparent Power S1	T16	Pn
24	Apparent Power S2	T16	Pn
25	Apparent Power S3	T16	Pn
26	Total Apparent Power S	T16	Pt
27	Power Factor PF1	T17	1
28	Power Factor PF2	T17	1
29	Power Factor PF3	T17	1
30	Total Power Factor PF	T17	1
31	CAP/IND P. F. Phase 1 (PF1)	T17	1
32	CAP/IND P. F. Phase 2 (PF2)	T17	1
33	CAP/IND P. F. Phase 3 (PF3)	T17	1
34	CAP/IND P. F. Total (PFt)	T17	1
35	Power Angle U1-I1	T17	100°
36	Power Angle U2-I2	T17	100°
37	Power Angle U3-I3	T17	100°
38	Power Angle atan2(Pt, Qt)	T17	100°
39	Angle U1-U2	T17	100°
40	Angle U2-U3	T17	100°
41	Angle U3-U1	T17	100°
42	Frequency	T17	Fn+10Hz
43	Voltage unbalance Uu	T16	100%
44	THD I1	T16	100%
45	THD I2	T16	100%
46	THD I3	T16	100%
47	THD U1	T16	100%
48	THD U2	T16	100%
49	THD U3	T16	100%
50	THD U12	T16	100%
51	THD U23	T16	100%
52	THD U31	T16	100%
	Max Demand Since Last Reset		
53	MD Real Power P (positive)	T16	Pt
54	MD Real Power P (negative)	T16	Pt
55	MD Reactive Power Q - L	T16	Pt
56	MD Reactive Power Q - C	T16	Pt
57	MD Apparent Power S	T16	Pt
58	MD Current I1	T16	In
59	MD Current I2	T16	In
60	MD Current I3	T16	In
	Dynamic Demand Values		

DNP3 Point	Parameter	Type	100% value
61	MD Real Power P (positive)	T16	Pt
62	MD Real Power P (negative)	T16	Pt
63	MD Reactive Power Q - L	T16	Pt
64	MD Reactive Power Q - C	T16	Pt
65	MD Apparent Power S	T16	Pt
66	MD Current I1	T16	In
67	MD Current I2	T16	In
68	MD Current I3	T16	In
69	Energy Counter 1	T17	Actual counter value MOD 20000 is returned
70	Energy Counter 2	T17	
71	Energy Counter 3	T17	
72	Energy Counter 4	T17	
73	Energy Counter 1 Cost	T17	
74	Energy Counter 2 Cost	T17	
75	Energy Counter 3 Cost	T17	
76	Energy Counter 4 Cost	T17	
77	Total Energy Counter Cost	T17	
78	Active Tariff	T1	

## Data types decoding

See Data types decoding in *Appendix A: Modbus protocol* on page 78.

## 100% values calculations

See 100% values calculations for normalized measurements in *Appendix A: Modbus protocol* on page 78.

# APPENDIX C: CALCULATIONS & EQUATIONS

## Calculations

### Definitions of symbols

No	Symbol	Definition
1	Mv	Sample factor
2	MP	Average interval
3	Uf	Phase voltage (U1, U2 or U3)
4	Uff	Phase-to-phase voltage (U12, U23 or U31)
5	N	Total number of samples in a period
6	n	Sample number ( $0 \leq n \leq N$ )
7	x, y	Phase number (1, 2 or 3)
8	in	Current sample n
9	ufn	Phase voltage sample n
10	uffn	Phase-to-phase voltage sample n
11	$\phi f$	Power angle between current and phase voltage f ( $\phi 1, \phi 2$ or $\phi 3$ )
12	Uu	Voltage unbalance
13	Uc	Agreed supply voltage

## Equations

### Voltage

$$U_f = \sqrt{\frac{\sum_{n=1}^N u_n^2}{N}}$$

Phase voltage

N - 128 samples in one period (up to 65 Hz)

N - 128 samples in  $M_v$  periods (above 65Hz)

Example: 400 Hz  $\rightarrow M_v = 7$

$$U_{xy} = \sqrt{\frac{\sum_{n=1}^N (u_{xn} - u_{yn})^2}{N}}$$

Phase-to-phase voltage

$u_x, u_y$  - phase voltages ( $U_f$ )

N - a number of samples in a period

$$U_u = \sqrt{\frac{1 - \sqrt{3 - 6\beta}}{1 + \sqrt{3 - 6\beta}}} \cdot 100\%$$

Voltage unbalance

$U_{fund}$  - first harmonic of phase-to-phase voltage

$$\beta = \frac{U_{12fund}^4 + U_{23fund}^4 + U_{31fund}^4}{(U_{12fund}^2 + U_{23fund}^2 + U_{31fund}^2)^2}$$

### Current

$$I_{RMS} = \sqrt{\frac{\sum_{n=1}^N i_n^2}{N}}$$

Phase current

N - 128 samples in a period (up to 65 Hz)

N - 128 samples in more periods (above 65 Hz)

$$I_n = \sqrt{\frac{\sum_{n=1}^N (i_{1n} + i_{2n} + i_{3n})^2}{N}}$$

Neutral current

i - n sample of phase current (1, 2 or 3)

N - 128 samples in a period (up to 65 Hz)

---

**Power**

---

$P_f = \frac{1}{N} \cdot \sum_{n=1}^N (u_{fn} \cdot i_{fn})$	Active power by phases N - a number of periods n - index of sample in a period f - phase designation
$P_t = P_1 + P_2 + P_3$	Total active power t - total power 1, 2, 3 - phase designation
$SignQ_f(\varphi)$ $\varphi \in [0^\circ - 180^\circ] \Rightarrow SignQ_f(\varphi) = +1$ $\varphi \in [180^\circ - 360^\circ] \Rightarrow SignQ_f(\varphi) = -1$	Reactive power sign Q <sub>f</sub> - reactive power (by phases) φ - power angle
$S_f = U_f \cdot I_f$	Apparent power by phases U <sub>f</sub> - phase voltage I <sub>f</sub> - phase current
$S_t = S_1 + S_2 + S_3$	Total apparent power S <sub>f</sub> - apparent power by phases
$Q_f = SignQ_f(\varphi) \cdot \sqrt{S_f^2 - P_f^2}$	Reactive power by phases S <sub>f</sub> - apparent power by phases P <sub>f</sub> - active power by phases
$Q_f = \frac{1}{N} \cdot \sum_{n=1}^N (u_{fn} \times i_{f[n+N/4]})$	Reactive power by phases (delayed current method) N - a number of samples in a period n - sample number (0 ≤ n ≤ N) f - phase designation
$Q_t = Q_1 + Q_2 + Q_3$	Total reactive power Q <sub>f</sub> - reactive power by phases
$\varphi_s = \arctan2(P_t, Q_t)$ $\varphi_s = [-180^\circ, 179,99^\circ]$	Total power angle P <sub>t</sub> - total active power S <sub>t</sub> - total apparent power
$PF_t = \frac{P_t}{S_t}$	Distortion factor P - total active power S - total apparent power
$PF_f = \frac{P_f}{S_f}$	Distortion factor P <sub>t</sub> - phase active power S <sub>t</sub> - phase apparent power

---

---

**THD**

---

$$I_f THD(\%) = \frac{\sqrt{\sum_{n=2}^{63} I_n^2}}{I_1} \cdot 100$$

Current THD  
 $I_1$  - value of first harmonic  
 $n$  - number of harmonic

---

$$U_f THD(\%) = \frac{\sqrt{\sum_{n=2}^{63} U_{fn}^2}}{U_{f1}} \cdot 100$$

Phase voltage THD  
 $U_1$  - value of first harmonic  
 $n$  - number of harmonic

---

$$U_{ff} THD(\%) = \frac{\sqrt{\sum_{n=2}^{63} U_{ffn}^2}}{U_{ff1}} \cdot 100$$

Phase-to-phase voltage THD  
 $U_1$  - value of first harmonic  
 $n$  - number of harmonic

---

**Flickers**

---

$$P_{50S} = (P_{30} + P_{50} + P_{80})/3$$

$$P_{10S} = (P_6 + P_8 + P_{10} + P_{13} + P_{17})/5$$

$$P_{3S} = (P_{2,2} + P_3 + P_4)/3$$

$$P_{1S} = (P_{1,7} + P_1 + P_{1,5})/3$$

$$P_{st} = \sqrt{0,0314P_{0,1} + 0,00525P_{1S} + 0,0657P_{3S} + 0,28P_{10S} + 0,08P_{50S}}$$

$P_{st}$  - Short-term flicker intensity  
Short-term flicker intensity is measured in 10 minute periods.  
 $P_x$  - flicker levels that are exceeded by  $x\%$  in a 10-minute period (e.g.  $P_{0,1}$  represents a flicker level that is exceeded by 0.1% samples)

---

$$P_{lt} = \sqrt[3]{\sum_{i=1}^{12} \frac{P_{sti}^3}{12}}$$

$P_{lt}$  - Long-term flicker intensity  
Calculated from twelve successive values of short-term flicker intensity in a two-hour period

---

**Energy**

---

$$\text{Price in tariff} = \text{Price} \cdot 10^{\text{Tariff price exponent}}$$

Total exponent of tariff price and energy price in all tariffs

---

# APPENDIX D: DATA FORMATS

## XML data format

Currently, two XML formats are available. XML-smart is general purpose XML format whereas XML-logic is more proprietary, suitable for special customers. For this purpose only XML-smart format will be explained.

## Explanation of XML data format

All data, which is prepared to be sent at next time interval is combined into element `<data>`. It comprises of elements `<value>`, which contain all information regarding every single reading.

Attributes of element `<value>` are:

- *logId*: Identification code of data package. It is used as a confirmation key and should therefore be unique for each device.
- *app*: application type ??
- *storeType*: data type ("measurement" or "alarm") or quality report??
- *dataProvider*: "xml001" ??
- *controlUnit*: Serial number of the device that sent this data
- *part*: recorder ??
- *datetimeUTC*: UTC date and time of the beginning of current time interval in which data was sent (yyyy-mm-dd hh:mm:ss).
- *ident*: ID code of particular reading
- *tFunc*: thermal function (1= ON / 0 = OFF)
- *cond*: condition (1 = lower than; 0 = higher then)
- *condVal*: limit value
- *almNum*: alarm serial number.
- *unit*: Measuring Parameter Unit (V, A, VA, W, VAr...)
- *tInterval*: sampling interval in minutes
- *dst*: (daylight savings time) in minutes
- *tzone*: timezone in minutes

## Example of alarms `<data>` package

```
data logId="033350088" app="ML" storeType="alarm" dataProvider="xml001" controlUnit="MC004475"
part="E" datetimeUTC="2009-07-15 21:29:07" dst="60" tzone=" 60">
<value ident="U1 " unit="V " tFunc="0" cond="0" condVal="200,00" almNum="01">100</value>
<value ident="U2 " unit="V " tFunc="0" cond="0" condVal="200,00" almNum="02">101</value>
<value ident="U3 " unit="V " tFunc="0" cond="0" condVal="200,00" almNum="03">99</value>
</data>
```

## Example of readings <data> package

```
<data logId="033324218" app="ML" storeType="measurement" dataProvider="xml001"
controlUnit="MC004475" part="B" datetimeUTC="2009-09-16 3:00:00" dst="60" tzone=" 60" tInterval="015">
<value ident="U1 " unit="V ">234,47</value>
<value ident="U2 " unit="V ">234,87</value>
<value ident="U3 " unit="V ">234,52</value>
<value ident="I1 " unit="A ">1,14</value>
<value ident="I2 " unit="A ">1,50</value>
<value ident="I3 " unit="A ">3,58</value>
<value ident="P1 " unit="W ">-0,063e+03</value>
<value ident="P2 " unit="W ">-0,101e+03</value>
<value ident="P3 " unit="W ">0,281e+03</value>
<value ident="P " unit="W ">0,11e+03</value>
<value ident="Q " unit="var ">-1,37e+03</value>
<value ident="E1 " unit="Wh">19620e+01</value>
<value ident="E2 " unit="varh">6e+01</value>
<value ident="E3 " unit="Wh">1303391e+01</value>
<value ident="E4 " unit="varh">2999595e+01</value>
<value ident="ePF " unit=" " >0,0820</value>
</data>
```

## Example of acknowledgement package:

```
<ack logId="033220002" datetimeUTC ="2008-01-31 23:00:50:000"></ack>
```

*Printed in Slovenia • Subject to change without notice • GB K 22.441.000*



**Iskra, d.d.**

Stegne 21

SI-1000 Ljubljana

Slovenia

Tel.: +386 1 51 31 000

Fax: +386 1 51 11 532

[www.iskra.eu](http://www.iskra.eu)

[info@iskra.eu](mailto:info@iskra.eu)