



SINGLE-POLE AND MULTI-POLE LIGHTING AND SURGE ARRESTERS FOR WIND GENERATION SYSTEM

CLASS II / (B+C)

$I_{IMP} = 25 \text{ kA}$ per pole, $I_{MAX} = 40 \text{ kA}$ per pole

COMPACT AND MODULAR DESIGN



WT ISPRO BS(R) 25



The WT ISPRO series has been developed to meet the growing needs of wind generation facilities where exposure to direct and indirect lightning discharges is well known problem, primarily due to the often exposed location of such facilities e.g. on hill tops and open land topography.

Category IEC/EN/VDE	Class II/Type 1,2/B+C
Location of use	Man distribution boards
Protection modes	L/N -PE
Protective elements	High Energy MOV
High surge discharge ratings	$I_{imp}=25kA$
Internal protection and safety	Compact design



Technical data

Type			WT ISPRO BS(R) 25/690
Standards			IEC-61643-1
Max. continuous operating voltage (AC/DC)	U_c	V	690/900
Nominal discharge current (8/20)	I_n	kA	40
Max. discharge current (8/20)	I_{max}	kA	80
Impulse current (10/350)	I_{imp}	kA	25
Specific energy		kJ/Ω	156
Charge		As	12.5
Protection level	U_p	kV	< 2.5
Residual voltage at I_{imp}	U_{res}	kV	< 2.0
Follow current	I_f	A_{RMS}	NO
Response time	t_A	ns	< 25
Residual current at U_c	I_{PE}	mA	< 3.5
Thermal protection			YES
Terminal screw torque		Nm	max. 4.5
Back-up fuse gL (if mains > 250 A)		A	250A gL
Short-circuit withstand current		kA	25kA/50Hz
Temperature range		°C	-40 ... +80
Terminal cross section	Solid	mm ²	35mm ²
	Stranded		25mm ²
Mounting EN 60715			35 mm top-hat rail
Degree of protection			IP 20
Housing material			thermoplastic; extinguishing degree UL 94 V-0
Dimensions DIN 43880			4TE
Weight per unit		kg	0,494



WT ISPRO BS(R) 25

ISPRO DMGR 10/xxx (with remote contacts)			
Remote contacts			YES
Contact ratings	250 V	A	0,5
	125 V		3
Terminal cross section		mm ²	max. 1.5
Remote terminal torque		Nm	0.25
Weight per unit		kg	0,499

Connection diagram

WT ISPRO BSR 25/690

Selection of back-up fuse

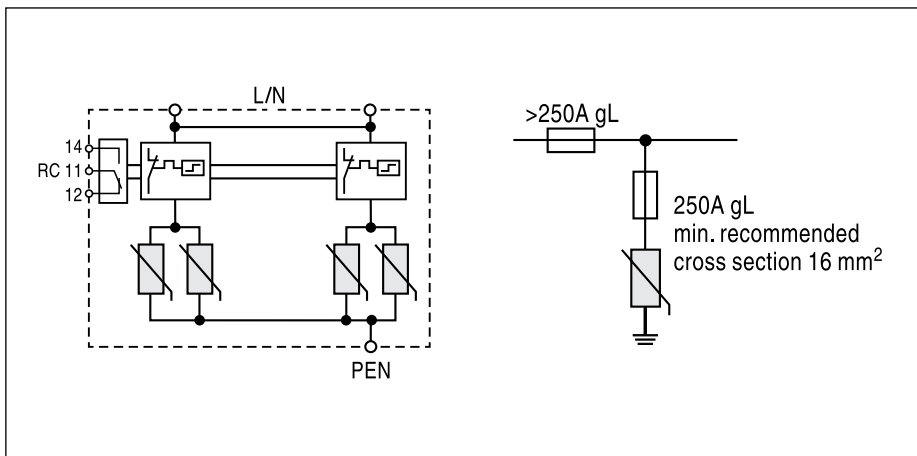

Dimensions

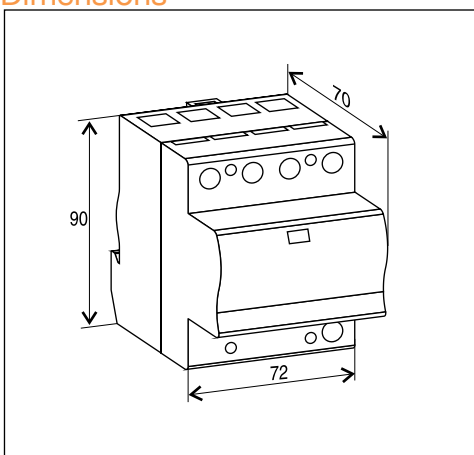

WT ISPRO BS(R) 12.5



The WT ISPRO series has been developed to meet the growing needs of wind generation facilities where exposure to direct and indirect lightning discharges is well known problem, primarily due to the often exposed location of such facilities e.g. on hill tops and open land topography.

Category IEC/EN/VDE	Class II/Type 1,2/B+C
Location of use	Man distribution boards
Protection modes	L/N -PE
Protective elements	High Energy MOV
High surge discharge ratings	$I_{imp}=25kA$ per pole
Internal protection and safety	Compact design



Technical data

Type		WT ISPRO BS(R) 12.5/690	
Standards			IEC-61643-1
Max. continuous operating voltage (AC/DC)	U_c	V	690/900
Nominal discharge current (8/20)	I_n	kA	20
Max. discharge current (8/20)	I_{max}	kA	40
Impulse current (10/350)	I_{imp}	kA	12.5
Specific energy		kJ/Ω	39
Charge		As	6.25
Protection level	U_p	kV	< 2.5
Residual voltage at I_{imp}	U_{res}	kV	< 2.0
Follow current	I_f	A_{RMS}	NO
Response time	t_A	ns	< 25
Residual current at U_c	I_{PE}	mA	< 2.5
Thermal protection			YES
Terminal screw torque		Nm	max. 4.5
Back-up fuse gL (if mains > 250 A)		A	250A gL
Short-circuit withstand current		kA	25kA/50Hz
Temperature range		° C	-40 ... +80
Terminal cross section	Solid	mm ²	35mm ²
	Stranded		25mm ²
Mounting EN 60715			35 mm top-hat rail
Degree of protection			IP 20
Housing material			thermoplastic; extinguishing degree UL 94 V-0
Dimensions DIN 43880			3TE
Weight per unit		kg	0,319



WT ISPRO BS(R) 12.5

ISPRO BSR 12.5 (with remote contacts)

Remote contacts			YES
Contact ratings	250 V	A	0,5
	125 V		3
Terminal cross section		mm ²	max. 1.5
Remote terminal torque		Nm	0.25
Weight per unit		kg	0,324

Connection diagram

WT ISPRO BSR 12.5/690

Selection of back-up fuse

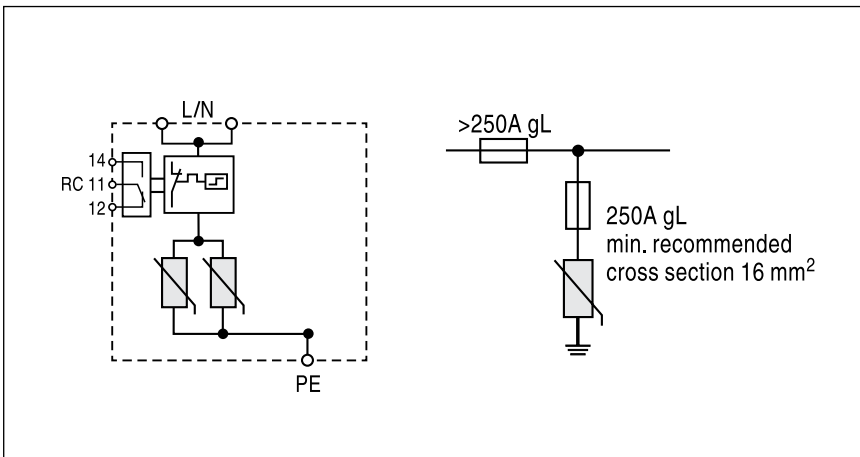

Dimensions

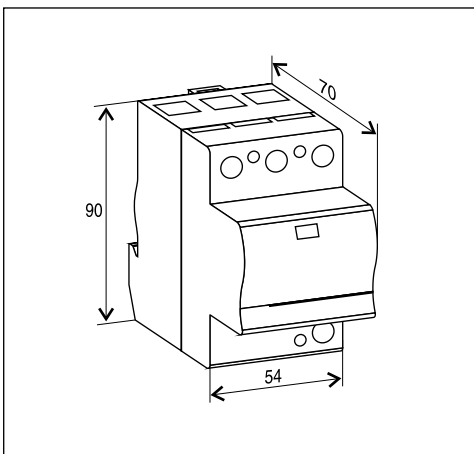

WT ISPRO C(R) 40



The WT ISPRO series has been developed to meet the growing needs of wind generation facilities where exposure to direct and indirect lightning discharges is well known problem, primarily due to the often exposed location of such facilities e.g. on hill tops and open land topography.

Category IEC/EN/VDE	Class II/Type 2/C
Location of use	Branch sub-distribution boards
Protection modes	L/N -PE, L-PEN
Protective elements	MOV
High surge discharge ratings	$I_{imp}=40\text{kA}$ per pole
Internal protection and safety	Modular design



Technical data

Type		WT ISPRO C(R) 40/690	
Standards			IEC-61643-1
Max. continuous operating voltage (AC/DC)	U_c	V	690/900
Nominal discharge current (8/20)	I_n	kA	20
Max. discharge current (8/20)	I_{max}	kA	40
Protection level	U_p	kV	< 3.0
Follow current	I_f		NO
Response time	t_A	ns	< 25
Residual current at U_c	I_{PE}	mA	< 1.5
Thermal protection			YES
Terminal screw torque		Nm	max. 4.5
Back-up fuse gL (if mains > 125 A)		A	125A gL
Short-circuit withstand current		kA	25kA/50Hz
Temperature range		°C	-40 ... +80
Terminal cross section	Solid	mm ²	35mm ²
	Stranded		25mm ²
Mounting EN 60715			35 mm top-hat rail
Degree of protection			IP 20
Housing material			thermoplastic; extinguishing degree UL 94 V-0
Dimensions DIN 43880			1TE
Weight per unit		g	142



WT ISPRO C(R) 40

WT ISPRO CR 40 (with remote contacts)			
Remote contacts			YES
Contact ratings	250 V	A	0,5
	125 V		3
Terminal cross section		mm ²	max. 1.5
Remote terminal torque		Nm	0.25
Weight per unit		kg	0,147

Connection diagram

WT ISPRO CR 40/690

Selection of back-up fuse

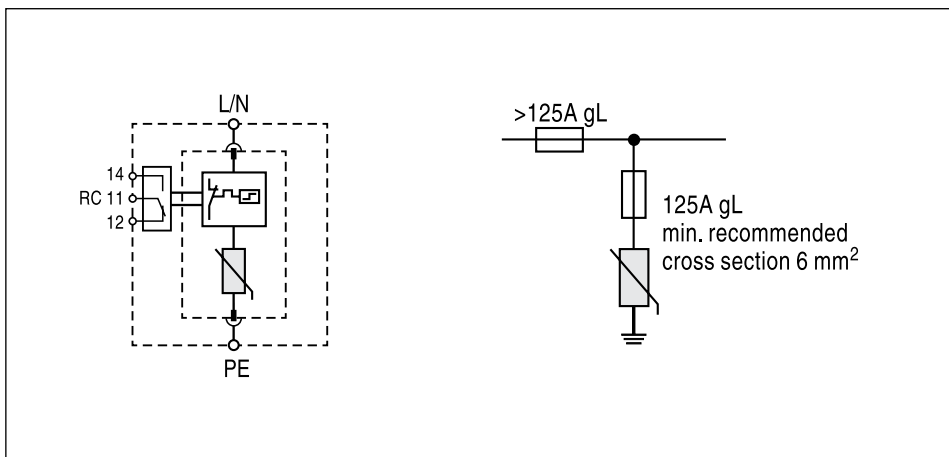

Dimensions

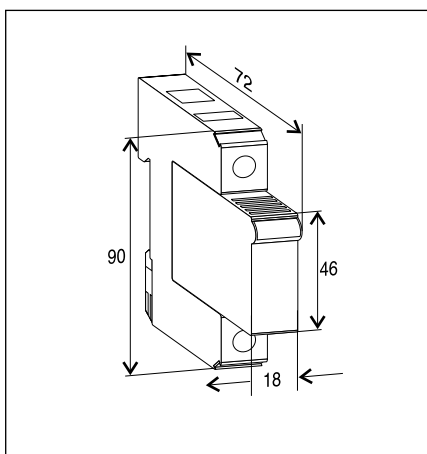

Accessory part for WT ISPRO C(R) 40

Type	Module WT ISPRO C(R) 40/xxx
	690



WT ISPRO C(R) 120 (3+0)



The WT ISPRO series has been developed to meet the growing needs of wind generation facilities where exposure to direct and indirect lightning discharges is well known problem, primarily due to the often exposed location of such facilities e.g. on hill tops and open land topography.

Category IEC/EN/DE	Class II/Type 2/C
Location of use	Branch sub-distribution boards
Protection modes	L/N -PE, L-PEN
Protective elements	MOV
High surge discharge ratings	$I_{imp}=40\text{kA}$ per pole
Internal protection and safety	Modular design



Technical data

Type			WT ISPRO C(R) 120/690 (3+0)
Standards			IEC-61643-1
Max. continuous operating voltage (AC/DC)	U_c	V	690/900
Nominal discharge current (8/20)	I_n	kA	20 per pole
Max. discharge current (8/20)	I_{max}	kA	40 per pole
Protection level	U_p	kV	< 3.0
Follow current	I_f		NO
Response time	t_A	ns	< 25
Residual current at U_c	I_{PE}	mA	< 1.5
Thermal protection			YES
Terminal screw torque		Nm	max. 4.5
Back-up fuse gL (if mains > 125 A)		A	125A gL
Short-circuit withstand current		kA	25kA/50Hz
Temperature range		°C	-40 ... +80
Terminal cross section	Solid	mm ²	35mm ²
	Stranded		25mm ²
Mounting EN 60715			35 mm top-hat rail
Degree of protection			IP 20
Housing material			thermoplastic; extinguishing degree UL 94 V-0
Dimensions DIN 43880			3TE
Weight per unit		kg	0,364



WT ISPRO C(R) 120 (3+0)

WT ISPRO C(R) 120 (with remote contacts)			
Remote contacts			YES
Contact ratings	250 V	A	0,5
	125 V		3
Terminal cross section		mm ²	max. 1.5
Remote terminal torque		Nm	0.25
Weight per unit		kg	0,369

TN-C Network (Three-Phase)

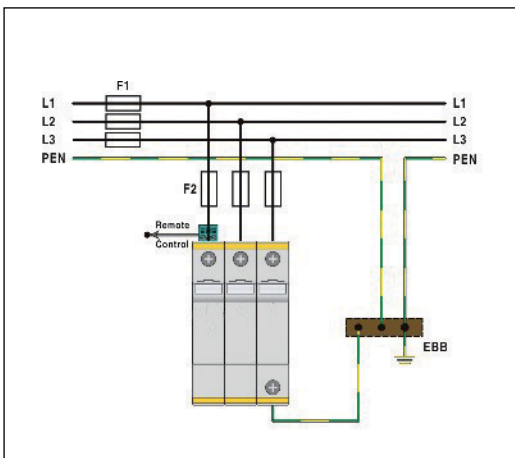

Connection diagram

WT ISPRO CR 120/690 (3+0)

Selection of back-up fuse

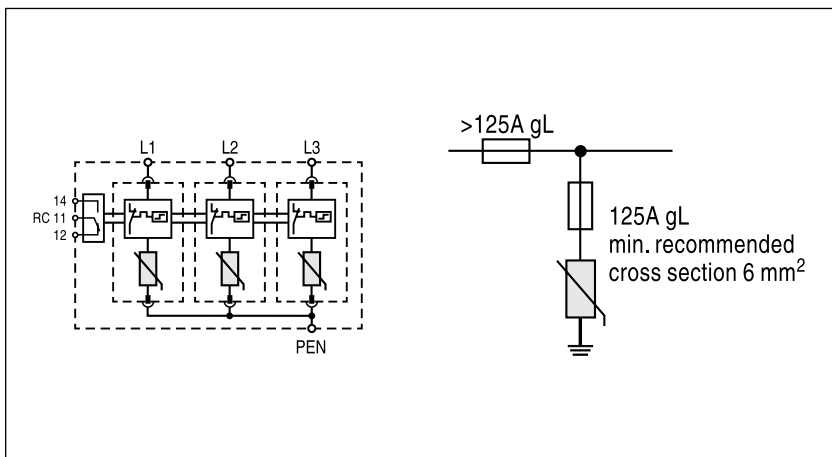

Dimensions

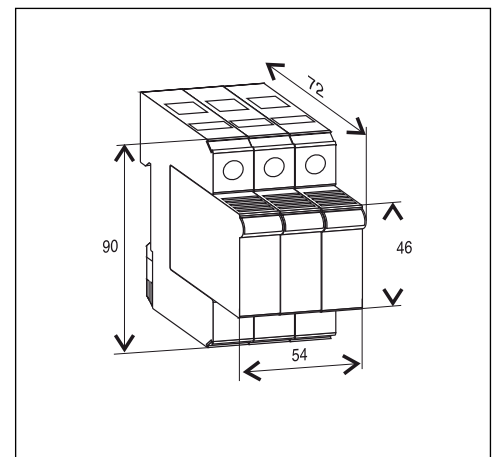

Accessory part for WT ISPRO C(R) 40/690

Type	Module WT ISPRO C(R) 40/xxx 690
------	------------------------------------

