

BISTABLE SWITCHES - up to 32 A Page 4-2



- Rated currents: 16 A, 20 A, 25 A, 32 A
- Mounting on 35 mm rail
- Switch position indicator
- No hold coil consumption
- Small switch on coil consumption
- Disconnection of remote control by selector switch for maintenance operation
- Accessories
- CE, CB

LATCHED CONTACTORS - up to 80 A Page 4-6



- Rated currents: 40, 63 and 80 A
- Mounting on 35 mm rail
- Switch position indicator
- No hold coil consumption
- Small switch on coil consumption
- Disconnection of remote control by selector switch for maintenance operation
- Accessories
- CE, CB

EXTENDED WITH A COMMUNICATIONS Page 4-8



- MODBUS communication
- IR communication
- Rated currents: 20, 25 and 32 A
- Mounting on 35 mm rail
- Switch position indicator
- No hold coil consumption
- Small switch on coil consumption
- Disconnection of remote control by selector switch for maintenance operation

BISTABLE SWITCHES ARE SWITCHING DEVICES WITH TWO STABLE STATES FOR SWITCHING OF ALL KIND OF ELECTRIC LOADS. WHEN THE SWITCH IS NOT INITIATED ELECTRICALLY OR ACTUATED MANUALLY, REMAINS STABLE IN ITS OPERATING POSITION AND WILL CHANGE ITS OPERATING POSITION ON INITIATION OR ACTUATION.

BISTABLE SWITCHES



BISTABLE SWITCHES ARE SWITCHING DEVICES WITHOUT POWER CONSUMPTION IN OPERATING SWITCH-ON POSITION AND VERY SMALL POWER CONSUMPTION PER POLE. ON A VERY EFFECTIVE WAY HELPS TO REDUCE GREENHOUSE GAS EMISSIONS OF CO₂.



FOR REMOTE SWITCHING

- Lights and lighting
- Electric heating
- Electric drives
- Intelligent installations

ADVANCED OPERATION

- Impulse control
- Manual control

OTHER BENEFITS

- Wide application
- Sealing terminal covers
- All control voltages from 8 V till 240 are possible
- With thermal and magnetic release

ORDERING DATA

Bistable switches up to 32 A	page 4-3
Accessories	page 4-11
Connections	page 4-27
Example - Ordering data	page 4-5
Technical characteristics	page 4-13
Dimensions	page 4-25

BISTABLE SWITCHES - UP TO 32 A

cos ϕ = 0.6 acc. to IEC/EN 60669-2-2 (2-pole, 1 module)

AC

Type	Rated current I _e	Control voltage at 50 Hz	Wiring diagram	Ordering No.	Weight (g)	Packaging (pcs)
BI216-20	16 A	230 V		30.070.278	135	8
BI216-20	16 A	24 V		30.070.279	135	8
BI216-11	16 A	230 V		30.070.276	135	8
BI216-11	16 A	24 V		30.070.277	135	8
BI216-1C	16 A	230 V		30.070.274	130	8
BI216-1C	16 A	24 V		30.070.275	130	8
BI216-10	16 A	230 V		30.070.272	130	8
BI216-10	16 A	24 V		30.070.273	130	8

4

cos ϕ = 0.6 acc. to IEC/EN 60669-2-2 (2-pole, 1 module)

AC

Type	Rated current I _e	Control voltage at 50 Hz	Wiring diagram	Ordering No.	Weight (g)	Packaging (pcs)
BI220-20	20 A	230 V		30.070.024	135	8
BI220-20	20 A	24 V		30.070.091	135	8
BI225-20	25 A	230 V		30.070.059	135	8
BI225-20	25 A	24 V		30.070.179	135	8
BI232-20	32 A	230 V		30.070.025	135	8
BI232-20	32 A	24 V		30.070.071	135	8
BI220-11	20 A	230 V		30.070.028	135	8
BI220-11	20 A	24 V		30.070.074	135	8
BI225-11	25 A	230 V		30.070.180	135	8
BI225-11	25 A	24 V		30.070.181	135	8
BI232-11	32 A	230 V		30.070.029	135	8
BI232-11	32 A	24 V		30.070.054	135	8
BI220-1C	20 A	230 V		30.070.182	130	8
BI220-1C	20 A	24 V		30.070.183	130	8
BI225-1C	25 A	230 V		30.070.063	130	8
BI225-1C	25 A	24 V		30.070.064	130	8
BI232-1C	32 A	230 V		30.070.184	130	8
BI232-1C	32 A	24 V		30.070.185	130	8
BI220-10	20 A	230 V		30.070.056	130	8
BI220-10	20 A	24 V		30.070.090	130	8
BI225-10	25 A	230 V		30.070.186	130	8
BI225-10	25 A	24 V		30.070.187	130	8
BI232-10	32 A	230 V		30.070.057	130	8
BI232-10	32 A	24 V		30.070.188	130	8



ORDERING DATA

BISTABLE SWITCHES - UP TO 32 A

cos ϕ = 0.6 acc. to IEC/EN 60669-2-2 (4-pole, 2 modules)

AC

Type	Rated current I _e	Control voltage at 50 Hz	Wiring diagram	Ordering No.	Weight (g)	Packaging (pcs)
BI416-40	16 A	230 V		30.070.300	195	4
BI416-40	16 A	24 V		30.070.484	195	4
BI416-31	16 A	230 V		30.070.485	195	4
BI416-31	16 A	24 V		30.070.486	195	4
BI416-30	16 A	230 V		30.070.487	185	4
BI416-30	16 A	24 V		30.070.488	185	4
BI416-22	16 A	230 V		30.070.489	195	4
BI416-22	16 A	24 V		30.070.490	195	4
BI416-2C	16 A	230 V		30.070.491	185	4
BI416-2C	16 A	24 V		30.070.492	185	4
BI416-21	16 A	230 V		30.070.493	185	4
BI416-21	16 A	24 V		30.070.494	185	4

cos ϕ = 0.6 acc. to IEC/EN 60669-2-2 (4-pole, 2 modules)

AC

Type	Rated current I _e	Control voltage at 50 Hz	Wiring diagram	Ordering No.	Weight (g)	Packaging (pcs)
BI420-40	20 A	230 V		30.070.026	195	4
BI420-40	20 A	24 V		30.070.189	195	4
BI425-40	25 A	230 V		30.070.060	195	4
BI425-40	25 A	24 V		30.070.190	195	4
BI432-40	32 A	230 V		30.070.027	195	4
BI432-40	32 A	24 V		30.070.072	195	4
BI420-31	20 A	230 V		30.070.031	195	4
BI420-31	20 A	24 V		30.070.191	195	4
BI425-31	25 A	230 V		30.070.192	195	4
BI425-31	25 A	24 V		30.070.193	195	4
BI432-31	32 A	230 V		30.070.033	195	4
BI432-31	32 A	24 V		30.070.194	195	4
BI420-30	20 A	230 V		30.070.195	185	4
BI420-30	20 A	24 V		30.070.196	185	4
BI425-30	25 A	230 V		30.070.197	185	4
BI425-30	25 A	24 V		30.070.198	185	4
BI432-30	32 A	230 V		30.070.199	185	4
BI432-30	32 A	24 V		30.070.200	185	4
BI420-22	20 A	230 V		30.070.030	195	4
BI420-22	20 A	24 V		30.070.065	195	4
BI425-22	25 A	230 V		30.070.201	195	4
BI425-22	25 A	24 V		30.070.202	195	4
BI432-22	32 A	230 V		30.070.032	195	4
BI432-22	32 A	24 V		30.070.055	195	4
BI420-2C	20 A	230 V		30.070.203	185	4
BI420-2C	20 A	24 V		30.070.204	185	4
BI425-2C	25 A	230 V		30.070.205	185	4
BI425-2C	25 A	24 V		30.070.206	185	4
BI432-2C	32 A	230 V		30.070.066	185	4
BI432-2C	32 A	24 V		30.070.067	185	4
BI420-21	20 A	230 V		30.070.207	185	4
BI420-21	20 A	24 V		30.070.208	185	4
BI425-21	25 A	230 V		30.070.165	185	4
BI425-21	25 A	24 V		30.070.209	185	4
BI432-21	32 A	230 V		30.070.210	185	4
BI432-21	32 A	24 V		30.070.211	185	4



ORDERING DATA

BISTABLE SWITCHES - UP TO 32 A

cos φ = 0.6 acc. to IEC/EN 60669-2-2 (2-pole, 1 module)

DC

Type	Rated current I _e	Control voltage at 50 Hz	Wiring diagram	Ordering No.	Weight (g)	Packaging (pcs)
BI216-20	16 A	24 V		30.070.283	135	8
BI216-11	16 A	24 V		30.070.282	135	8
BI216-1C	16 A	24 V		30.070.281	130	8
BI216-10	16 A	24 V		30.070.280	125	8

cos φ = 0.6 acc. to IEC/EN 60669-2-2 (2-pole, 1 module)

DC

Type	Rated current I _e	Control voltage	Wiring diagram	Ordering No.	Weight (g)	Packaging (pcs)
BI220-20	20 A	24 V		30.070.212	135	8
BI225-20	25 A	24 V		30.070.213	135	8
BI232-20	32 A	24 V		30.070.214	135	8
BI220-11	20 A	24 V		30.070.174	135	8
BI225-11	25 A	24 V		30.070.215	135	8
BI232-11	32 A	24 V		30.070.216	135	8
BI220-1C	20 A	24 V		30.070.217	130	8
BI225-1C	25 A	24 V		30.070.218	130	8
BI232-1C	32 A	24 V		30.070.219	130	8
BI220-10	20 A	24 V		30.070.152	125	8
BI225-10	25 A	24 V		30.070.220	125	8
BI232-10	32 A	24 V		30.070.221	125	8



BI8XX ARE SPECIAL VERSIONS OF BISTABLE SWITCHES WITH 8 POLES FOR APPLICATIONS WHERE REQUIRES A LARGE NUMBERS OF MECHANICAL CONNECTED CONTACTS.

cos φ = 0.6 acc. to IEC/EN 60669-2-2 (8-pole, 4 modules)

AC

Type	Rated current I _e	Control voltage at 50 Hz	Wiring diagram	Ordering No.	Weight (g)	Packaging (pcs)
BI820-80	20 A	230 V		30.070.222	390	2
BI825-80	25 A	230 V		30.070.223	390	2
BI832-80	32 A	230 V		30.070.224	390	2
BI820-62	20 A	230 V		30.070.225	390	2
BI825-62	25 A	230 V		30.070.226	390	2
BI832-62	32 A	230 V		30.070.227	390	2
BI820-44	20 A	230 V		30.070.228	390	2
BI825-44	25 A	230 V		30.070.229	390	2
BI832-44	32 A	230 V		30.070.230	390	2
BI820-4C	20 A	230 V		30.070.231	370	2
BI825-4C	25 A	230 V		30.070.232	370	2
BI832-4C	32 A	230 V		30.070.233	370	2

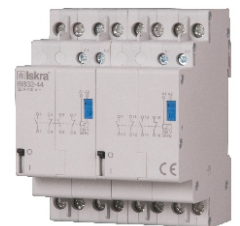

ORDERING DATA

BI220 - 20 12 V 50 Hz

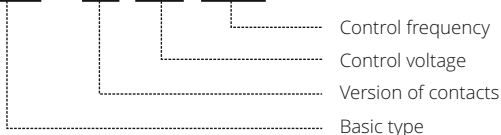

ORDERING DATA

LATCHED CONTACTORS



BISTABLE SWITCHES ARE SWITCHING DEVICES WITHOUT POWER CONSUMPTION IN OPERATING SWITCH-ON POSITION AND VERY SMALL POWER CONSUMPTION PER POLE. ON A VERY EFFECTIVE WAY HELPS TO REDUCE GREENHOUSE GAS EMISSIONS OF CO₂.



FOR REMOTE SWITCHING

- Lights and lighting
- Electric heating
- Electric drives
- Intelligent installations

ADVANCED OPERATION

- Impulse control
- Manual control

OTHER BENEFITS

- Wide application
- Sealing terminal covers
- All control voltages from 8 V till 240 V are possible
- With thermal and magnetic release

ORDERING DATA

Latched contactors up to 80 A	page 4-7
Accessories	page 4-11
Connections	page 4-27
Example - Ordering data	page 4-7
Technical characteristics	page 4-18
Dimensions	page 4-25

LATCHED CONTACTORS - UP TO 80 A

AC-1 acc. to IEC/EN 60947-4-1 (2-pole, 2 modules)

AC

Type	Rated current I _e	Control voltage at 50 Hz	Wiring diagram	Ordering No.	Weight (g)	Packaging (pcs)	
BI240-20	40 A	230 V		30.075.003	265	4	
BI240-20	40 A	24 V		30.075.004	265	4	
BI263-20	63 A	230 V		30.075.005	265	4	
BI263-20	63 A	24 V		30.075.006	265	4	
BI280-20	80 A	230 V		30.075.007	265	4	
BI240-11	40 A	230 V			30.075.008	265	4
BI240-11	40 A	24 V			30.075.009	265	4
BI263-11	63 A	230 V	30.075.010		265	4	
BI263-11	63 A	24 V	30.075.011		265	4	
BI280-11	80 A	230 V	30.075.012		265	4	
BI240-1C	40 A	230 V		30.075.013	250	4	
BI240-1C	40 A	24 V		30.075.014	250	4	
BI263-1C	63 A	230 V		30.075.015	250	4	
BI263-1C	63 A	24 V	30.075.016	250	4		
BI280-1C	80 A	230 V	30.075.017	250	4		
BI240-10	40 A	230 V		30.075.018	240	4	
BI240-10	40 A	24 V		30.075.019	240	4	
BI263-10	63 A	230 V		30.075.020	240	4	
BI263-10	63 A	24 V		30.075.021	240	4	
BI280-10	80 A	230 V		30.075.022	240	4	



4

AC-1 acc. to IEC/EN 60947-4-1 (4-pole, 4 modules)

Type	Rated current I _e	Control voltage at 50 Hz	Wiring diagram	Ordering No.	Weight (g)	Packaging (pcs)	
BI440-40	40 A	230 V		30.075.023	400	2	
BI440-40	40 A	24 V		30.075.024	400	2	
BI463-40	63 A	230 V		30.075.025	400	2	
BI463-40	63 A	24 V		30.075.026	400	2	
BI480-40	80 A	230 V		30.075.027	400	2	
BI440-31	40 A	230 V			30.075.028	400	2
BI440-31	40 A	24 V			30.075.029	400	2
BI463-31	63 A	230 V	30.075.030		400	2	
BI463-31	63 A	24 V	30.075.031		400	2	
BI480-31	80 A	230 V	30.075.032		400	2	
BI440-30	40 A	230 V		30.075.033	375	2	
BI440-30	40 A	24 V		30.075.034	375	2	
BI463-30	63 A	230 V		30.075.035	375	2	
BI463-30	63 A	24 V	30.075.036	375	2		
BI480-30	80 A	230 V	30.075.037	375	2		
BI440-22	40 A	230 V		30.075.038	400	2	
BI440-22	40 A	24 V		30.075.039	400	2	
BI463-22	63 A	230 V		30.075.040	400	2	
BI463-22	63 A	24 V		30.075.041	400	2	
BI480-22	80 A	230 V		30.075.042	400	2	
BI440-2C	40 A	230 V		30.075.043	385	2	
BI440-2C	40 A	24 V		30.075.044	385	2	
BI463-2C	63 A	230 V		30.075.045	385	2	
BI463-2C	63 A	24 V	30.075.046	385	2		
BI480-2C	80 A	230 V	30.075.047	385	2		
BI440-21	40 A	230 V		30.075.048	385	2	
BI440-21	40 A	24 V		30.075.049	385	2	
BI463-21	63 A	230 V		30.075.050	385	2	
BI463-21	63 A	24 V		30.075.051	385	2	
BI480-21	80 A	230 V		30.075.052	385	2	



ORDERING DATA

BI240 - 20 24 V 50 Hz

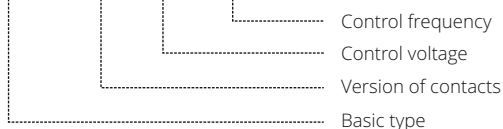

ORDERING DATA



BISTABLE SWITCHES WITH A COMMUNICATIONS CAN, MODBUS, I/O AND M-BUS ARE SPECIAL VERSIONS FOR USE IN SMART BUILDINGS, SMART INSTALLATIONS, DEMAND-SIDE-MANAGEMENT AND INDUSTRY SOLUTIONS. THEY HAVE FOUR SEPARATED CONTACTS FOR LOADS UP TO 32 A.



FOR REMOTE SWITCHING

- Lights and lighting
- Electric heating
- Electric drives
- Intelligent installations

ADVANCED OPERATION

- Impulse control
- Manual control

OTHER BENEFITS

- Wide application
- Sealing terminal covers
- All control voltages from 8 V till 240 V are possible
- With thermal and magnetic release only

ORDERING DATA

Bistable switches with a communications - BICOM up to 32 A page 4-9

Example - Ordering data page 4-10

Technical characteristics page 4-23

Dimensions page 4-25

BISTABLE SWITCHES WITH A COMMUNICATIONS - BICOM

ISO 11898 CAN compatible standard interface

Type	Rated current I_n	Control voltage at 50 Hz	Wiring diagram	Ordering No.	Weight (g)	Packaging (pcs)
BICOM420-40-CAN	20 A	230 V		22.459.113.001	220	2
BICOM425-40-CAN	25 A	230 V		22.459.113.002	220	2
BICOM432-40-CAN	32 A	230 V		22.459.113.003	220	2
BICOM420-31-CAN	20 A	230 V		22.459.113.004	220	2
BICOM425-31-CAN	25 A	230 V		22.459.113.005	220	2
BICOM432-31-CAN	32 A	230 V		22.459.113.006	220	2
BICOM420-30-CAN	20 A	230 V		22.459.113.007	220	2
BICOM425-30-CAN	25 A	230 V		22.459.113.008	220	2
BICOM432-30-CAN	32 A	230 V		22.459.113.009	220	2
BICOM420-22-CAN	20 A	230 V		22.459.113.010	220	2
BICOM425-22-CAN	25 A	230 V		22.459.113.011	220	2
BICOM432-22-CAN	32 A	230 V		22.459.113.012	220	2

AC



4

Modbus-RTU high-speed RS-485 communication

Type	Rated current I_n	Control voltage at 50 Hz	Wiring diagram	Ordering No.	Weight (g)	Packaging (pcs)
BICOM420-40-MODBUS	20 A	230 V		22.459.111.001	220	2
BICOM425-40-MODBUS	25 A	230 V		22.459.111.002	220	2
BICOM432-40-MODBUS	32 A	230 V		22.459.111.003	220	2
BICOM420-31-MODBUS	20 A	230 V		22.459.111.004	220	2
BICOM425-31-MODBUS	25 A	230 V		22.459.111.005	220	2
BICOM432-31-MODBUS	32 A	230 V		22.459.111.006	220	2
BICOM420-30-MODBUS	20 A	230 V		22.459.111.007	220	2
BICOM425-30-MODBUS	25 A	230 V		22.459.111.008	220	2
BICOM432-30-MODBUS	32 A	230 V		22.459.111.009	220	2
BICOM420-22-MODBUS	20 A	230 V		22.459.111.010	220	2
BICOM425-22-MODBUS	25 A	230 V		22.459.111.011	220	2
BICOM432-22-MODBUS	32 A	230 V		22.459.111.012	220	2

AC



Standard I/O communication

Type	Rated current I_n	Control voltage at 50 Hz	Wiring diagram	Ordering No.	Weight (g)	Packaging (pcs)
BICOM420-40-I/O	20 A	230 V		22.459.112.001	220	2
BICOM425-40-I/O	25 A	230 V		22.459.112.002	220	2
BICOM432-40-I/O	32 A	230 V		22.459.112.003	220	2
BICOM420-31-I/O	20 A	230 V		22.459.112.004	220	2
BICOM425-31-I/O	25 A	230 V		22.459.112.005	220	2
BICOM432-31-I/O	32 A	230 V		22.459.112.006	220	2
BICOM420-30-I/O	20 A	230 V		22.459.112.007	220	2
BICOM425-30-I/O	25 A	230 V		22.459.112.008	220	2
BICOM432-30-I/O	32 A	230 V		22.459.112.009	220	2
BICOM420-22-I/O	20 A	230 V		22.459.112.010	220	2
BICOM425-22-I/O	25 A	230 V		22.459.112.011	220	2
BICOM432-22-I/O	32 A	230 V		22.459.112.012	220	2

AC



ORDERING DATA

BISTABLE SWITCHES WITH A COMMUNICATIONS - BICOM

IR communication

AC

Type	Rated current I _e	Control voltage at 50 Hz	Wiring diagram	Ordering No.	Weight (g)	Packaging (pcs)
BICOM420-40-WM1	20 A	230 V	A1A2 1 3 5 7	22.459.113.001	220	2
BICOM425-40-WM1	25 A	230 V		22.459.113.002	220	2
BICOM432-40-WM1	32 A	230 V	2 4 6 8	22.459.113.003	220	2
BICOM420-31-WM1	20 A	230 V	A1A2 1 3 5 7	22.459.113.004	220	2
BICOM425-31-WM1	25 A	230 V		22.459.113.005	220	2
BICOM432-31-WM1	32 A	230 V	2 4 6 8	22.459.113.006	220	2
BICOM420-30-WM1	20 A	230 V	A1A2 1 3 5	22.459.113.007	220	2
BICOM425-30-WM1	25 A	230 V		22.459.113.008	220	2
BICOM432-30-WM1	32 A	230 V	2 4 6	22.459.113.009	220	2
BICOM420-22-WM1	20 A	230 V	A1A2 1 3 5 7	22.459.113.010	220	2
BICOM425-22-WM1	25 A	230 V		22.459.113.011	220	2
BICOM432-22-WM1	32 A	230 V	2 4 6 8	22.459.113.012	220	2



4

ORDERING DATA

BICOM420 - 40 / 20 A - xxx

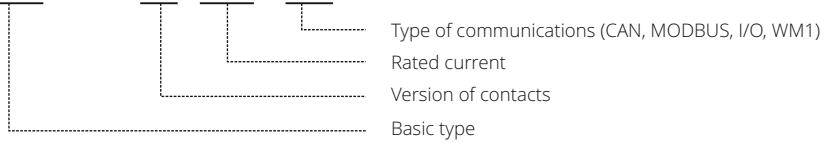

ORDERING DATA

BISTABLE SWITCHES - ACCESSORIES

Sealing cover for bistable switches up to 32 A

Type	Ordering No.	Weight (g)	Packaging (pcs)
B132-PP	37.425.439	4	2



Sealing cover for bistable switches up to 80 A

Type	Ordering No.	Weight (g)	Packaging (pcs)
B180-PP	37.425.484	4	2



Auxiliary switch

AC-15 acc. to IEC/EN 60947-5-1 (2-pole, ½ module)

Type	Rated current I _e	Rated voltage U _e	Wiring diagram			Ordering No.	Weight (g)	Packaging (pcs)
			-20	-11	-1C			
BIN20	4 A	250 V				38.070.012	30	1
BIN11	4 A	250 V				38.070.013	30	1
BIN1C	4 A	250 V				38.070.014	30	1



Auxiliary device for centralised control (½ module)

Type	Ordering No.	Weight (g)	Packaging (pcs)
BIC	38.070.010	30	1



Auxiliary device for group control (½ module)

Type	Ordering No.	Weight (g)	Packaging (pcs)
BIG	38.070.011	30	1



Compensation capacitor

Type	Ordering No.	Weight (g)	Packaging (pcs)
BIK	38.070.009	17	1



4

ORDERING DATA

BISTABLE SWITCHES - ACCESSORIES

4-phase busbars for bistable switches up to 32 A - insulated

Type	Module width	Length (mm)	Ordering No.	Weight (g)	Packaging (pcs)
L/32-8P	4	66	38.046.061	60	10
L/32-12P	6	98	38.046.062	86	
L/32-16P	8	138	38.046.063	114	
L/32-20P	10	173	38.046.064	141	
L/32-24P	12	208	38.046.065	169	

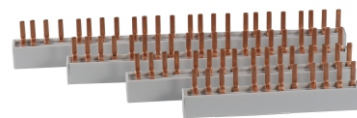

4

Single-pin terminals for bistable switches up to 32 A - insulated

Type	Pin length	Cross-section rigid/flexible (mm ²)	Screw	Ordering No.	Weight (g)	Packaging (pcs)
S/32-1P	13.5/32 (total)	6-25/4-16	PZ2	38.046.066	12	25



ORDERING DATA

BISTABLE SWITCHES - UP TO 32 A

4

		Symbol	Unit	BI216	BI220	BI225	BI232
GENERAL	Type						
	Standards			IEC/EN 60669-2-2			
	Approvals			CE		CE, CB	
	Disconnection of remote control by selector switch (coil: on/off)			no		yes	
	Module width				1		
	Number of poles				2		
	Degree of protection					IP20	
	Pollution degree					3	
	Climatic conditions					95 % relative humidity	
	Ambient temperature (open)		°C	-25 ... +55 (>55 ... +70 at max. impulse duration which is 1 min)			
	Storage temperature		°C	-30 ... +80			
	Maximum altitude		m	2000			
	U_i and U_e is reduced for 1.2 % and I_e for 0.4 % for every additional 100 m						
	Number of contactors or switches side-by-side:					no limitation	
	≤40 °C					AC: no limitation / DC: max. 3	
	(40 ... 55) °C					AC: max. 3 / DC: 0	
	(55 ... 70) °C					AC: max. 3 / DC: 0	
	Noise level (operation)		dB	0 (coil voltage is switched off)			
	Vibration resistance according to IEC/EN 60068-2-6	a	g	3 (Z axis)			
	Shock resistance according to IEC/EN 6068-2-27	a	g	15 (Z axis)			
Maximum operating frequency with no load		op./h	900			450	
Mechanical endurance		op. c.		1.000.000			
Weight		g	135				
MAIN CIRCUIT	Contact reliability			≥10 V; ≥100 mA			
	Minimum distance of open contacts		mm	>3			
	Power dissipation per pole		W	1	1.5	2	3
	Overload current withstand capability:						
	10 s		A	48	56	64	80
	Maximum back-up fuse for short-circuit protection gL and gG: coordination type 1 (at prospective current 3 kA)	I_L	A	16	20	25	32
	Rated insulation voltage	U_i	V	440			
	Rated impulse withstand voltage	U_{imp}	kV	4			
	Rated operational voltage	U_e	V	440			
	Rated frequency	f	Hz	50/60			
	Thermal current	I_{th}	A	16	20	25	32
	Rated operational current for $\cos\phi = 0.6$ acc. to IEC/EN 60669-2-2			16	20	25	32
	Maximum operating frequency for $\cos\phi = 0.6$ acc. to IEC/EN 60669-2-2		op./h	900			450
	Electrical endurance for $\cos\phi = 0.6$ acc. to IEC/EN 60669-2-2		op. c.		100.000		
	Rated operational current for AC-1, AC-7a and AC-21	I_e	A	16	20	25	32
	Operational power for AC-1, AC-7a and AC-21: single-phase 230 V	P_e	kW	3.5	4.4	5.5	7
	Maximum operating frequency for AC-1, AC-7a and AC-21		op./h	600			450
	Electrical endurance for AC-1, AC-7a and AC-21		op. c.		100.000		
	Rated operational current for AC-2	I_e	A	8	10	13	16
	Operational power for AC-2: single-phase 230 V	P_e	kW	1.2	1.5	2	2.4
	Maximum operating frequency for AC-2		op./h		120		
	Electrical endurance for AC-2		op. c.		100.000		
	Rated operational current for AC-3, AC-7b and AC-23	I_e	A	5	7	8	10
	Operational power for AC-3, AC-7b and AC-23: single-phase 230 V	P_e	kW	0.37	0.55	0.75	1.1
	Maximum operating frequency for AC-3, AC-7b and AC-23		op./h	600			450
	Electrical endurance for AC-3, AC-7b and AC-23		op. c.		100.000		
	Rated operational current for AC-5a (at 230 V)	I_e	A		16		
	Maximum operating frequency for AC-5a		op./h	600			450
	Electrical endurance for AC-5a		op. c.		100.000		
	Rated operational current for AC-5b (at 230 V)	I_e	A	¹ 10		¹ 10 / ² 12	¹ 10 / ³ 16
	Maximum operating frequency for AC-5b		op./h	600			450
	Electrical endurance for AC-5b		op. c.		¹ 100.000 / ² 60.000 / ³ 20.000		

TECHNICAL DATA

BISTABLE SWITCHES - UP TO 32 A

Type	Symbol	Unit	BI216	BI220	BI225	BI232
Rated operational current for AC-6a (at 230 V)	I_e	A	2.8	3	3.6	4.5
Maximum operating frequency for AC-6a		op./h	600		450	
Electrical endurance for AC-6a		op. c.	100,000			
Switching of capacitors AC-6b and AC-7c (at 230 V)	C	μ F	80	100	120	150
Maximum operating frequency for AC-6b and AC-7c		op./h	600		450	
Electrical endurance for AC-6b and AC-7c		op. c.	100,000			
Rated operational current for DC-1 (L/R \leq 1 ms): 1 pole ... 24 V DC/48 V DC/60 V DC/110 V DC/ 220 V DC 2 poles in series ... 24 V DC/48 V DC/60 V DC/110 V DC/ 220 V DC	I_e	A	16/12/8/4/0.4 16/15/14/7/3	20/15/10/5/0.5 20/18/15/8/4	25/20/15/6/0.6 25/25/20/10/5	32/25/20/7/0.7 32/28/22/12/6
Maximum operating frequency for DC-1		op./h	300			
Electrical endurance for DC-1		op. c.	100,000			
Rated operational current for DC-3 (L/R \leq 2 ms): 1 pole ... 24 V DC/48 V DC/60 V DC/110 V DC/ 220 V DC 2 poles in series ... 24 V DC/48 V DC/60 V DC/110 V DC/ 220 V DC	I_e	A	9/4/2/1/0.1 16/9/7/3/0.3	10/5/2/1/0.1 20/10/8/3/0.4	15/8/3/1/1/0.2 25/16/12/4/0.6	18/10/4/1.2/0.3 32/18/14/5/0.8
Maximum operating frequency for DC-3		op./h	300			
Electrical endurance for DC-3		op. c.	100,000			
Rated operational current for DC-5 (L/R \leq 7.5 ms): 1 pole ... 24 V DC/48 V DC/60 V DC/110 V DC/ 220 V DC 2 poles in series ... 24 V DC/48 V DC/60 V DC/110 V DC/ 220 V DC	I_e	A	9/3/1/0.3/0.05 16/7/5/1.5/0.1	10/4/1/0.3/0.05 20/8/6/2/0.2	15/5/2/0.5/0.08 25/15/10/3/0.4	18/6/3/0.8/0.1 32/16/12/4/0.6
Maximum operating frequency for DC-5		op./h	300			
Electrical endurance for DC-5		op. c.	100,000			
Terminal capacity: rigid (solid and stranded)	S	mm ²	1 ... 10			
flexible			1 ... 10			
Length of removed wire insulation		mm	9			
Screw			M4			
Screw head			PZ2			
Tightening torque		Nm	1.2			
Range of control voltage for switch-on	U_c	%	90 ... 110			
Range of control voltage for drop out	U_c	%	AC: 75 ... 20 / DC: 75 ... 10			
Kind of voltage			AC or DC			
Standard control voltages	U_c	V	AC: 8, 12, 24, 48, 120, 230, 240 / DC: 12, 24, 48, 110, 220			
Frequency of AC control voltage	f	Hz	AC: 50 or 60			
Control mode			remote control with impulse voltage / manual control			
Impulse duration of control voltage: minimum			AC: 50 ms / DC: 100 ms			
optimum - recommended			AC: 100 ... 500 ms / DC: 150 ... 500 ms			
maximum (only in case of breakdown of control system)			AC: 1 hour / DC: 1 minute			
Minimum duration between two impulses of control voltage		ms	AC: 150 / DC: 500			
Surge immunity withstand voltage 1.2/50 μ s acc. to standard IEC/EN 61000-4-5		kV	3			
Coil consumption: switch-on		VA/W	AC: 18/13 / DC: 9/9			
operation			AC: 9/4 / DC: 9/9			
Delays: make		ms	AC: 5 ... 20 / DC: 8 ... 35			
brake			AC: 5 ... 20 / DC: 8 ... 35			
Terminal capacity: rigid (solid and stranded)		mm ²	1 ... 4			
flexible			1 ... 4			
Length of removed wire insulation		mm	7			
Screw			M3			
Screw head			PZ1			
Tightening torque		Nm	0.6			
MTTF - Mean time to failure MTTF = $1/\lambda = B10/(0.1 n_{op})$		h	4.166			
MTTF _d - Mean time to failure dangerous MTTF _d = $1/\lambda_d = B10_d/(0.1 n_{op})$		h	8.333			
B10 - Number of operating cycles until 10 % of devices fail		op. c.	50,000			
B10 _d - Number of operating cycles until 10 % of device dangerous B10 _d = B10/ratio of dangerous failures		op. c.	100,000			
λ - Failure rate $\lambda = (0.1 n_{op})/B10$		1/h	0.00024			
λ_d - Failure rate dangerous $\lambda_d = (0.1 n_{op})/B10_d$		1/h	0.00012			
Ratio of dangerous failures		%	50			
n_{op} - Operating cycles (operating cycles/h)		op. c./h	120			

MAIN CIRCUIT

COIL

SAFETY

TECHNICAL DATA

BISTABLE SWITCHES - UP TO 32 A

Type	Symbol	Unit	BI416	BI420 BI820	BI425 BI825	BI432 BI832
Standards			IEC/EN 60669-2-2			
Approvals			CE, CB			
Disconnection of remote control by selector switch (coil: on/off)			no	yes		
Module width			2	BI420: 2/BI820: 4	BI425: 2/BI825: 4	BI432: 2/BI832: 4
Number of poles			4	BI420: 4/BI820: 8	BI425: 4/BI825: 8	BI432: 4/BI832: 8
Degree of protection			IP20			
Pollution degree			3			
Climatic conditions			95 % relative humidity			
Ambient temperature (open)		°C	-25 ... +55 (>55 ... +70 at max. impulse duration which is 1 min)			
Storage temperature		°C	-30 ... +80			
Maximum altitude		m	2000			
U _i and U _e is reduced for 1.2 % and I _e for 0.4 % for every additional 100 m						
Number of contactors or switches side-by-side:			no limitation			
≤40 °C			max. 3			
(40 ... 55) °C			max. 1			
(55 ... 70) °C						
Noise level (operation)		dB	0 (coil voltage is switched off)			
Vibration resistance according to IEC/EN 60068-2-6	a	g	3 (Z axis)			
Shock resistance according to IEC/EN 6068-2-27	a	g	15 (Z axis)			
Maximum operating frequency with no load		op./h	900			450
Mechanical endurance		op. c.	1.000.000			
Weight		g	BI4xx: 195/BI8xx: 390			
Contact reliability			≥10 V; ≥100 mA			
Minimum distance of open contacts		mm	>3			
Power dissipation per pole		W	1	1.5	2	3
Overload current withstand capability:						
10 s		A	48	56	68	96
Maximum back-up fuse for short-circuit protection gL and gG: coordination type 1	I _v	A	18	20	25	32
Rated insulation voltage	U _i	V	440			
Rated impulse withstand voltage	U _{imp}	kV	4			
Rated operational voltage	U _e	V	440			
Rated frequency	f	Hz	50/60			
Thermal current	I _{th}	A	16	20	25	32
Rated operational current for cosφ = 0.6 acc. to IEC/EN 60669-2-2			16	20	25	32
Maximum operating frequency for cosφ = 0.6 acc. to IEC/EN 60669-2-2		op./h	900			450
Electrical endurance for cosφ = 0.6 acc. to IEC/EN 60669-2-2		op. c.	100.000			
Rated operational current for AC-1, AC-7a and AC-21	I _e	A	16	20	25	32
Operational power for AC-1, AC-7a and AC-21:						
single-phase 230 V	P _e	kW	3.5	4.4	5.5	7
three-phase 230 V			6	7.6	9.5	12.1
three-phase 400 V			10.5	13.2	16.5	21
Maximum operating frequency for AC-1, AC-7a and AC-21		op./h	600			450
Electrical endurance for AC-1, AC-7a and AC-21		op. c.	100.000			
Rated operational current for AC-2	I _e	A	8	10	13	16
Operational power for AC-2:						
single-phase 230 V	P _e	kW	1.2	1.5	2	2.4
three-phase 230 V			2	2.6	3.3	4.1
three-phase 400 V			3.6	4.5	5.8	7.2
Maximum operating frequency for AC-2		op./h	120			
Electrical endurance for AC-2		op. c.	100.000			
Rated operational current for AC-3, AC-7b and AC-23	I _e	A	5	7	8.5	12
Operational power for AC-3, AC-7b and AC-23:						
single-phase 230 V	P _e	kW	0.37	0.5	0.75	1.1
three-phase 230 V			1.1	1.5	2.2	3
three-phase 400 V			2.2	3	4	5.5
Maximum operating frequency for AC-3, AC-7b and AC-23		op./h	600			450
Electrical endurance for AC-3, AC-7b and AC-23		op. c.	100.000			
Rated operational current for AC-5a (at 230 V)	I _e	A	16			
Maximum operating frequency for AC-5a		op./h	600			450
Electrical endurance for AC-5a		op. c.	100.000			
Rated operational current for AC-5b (at 230 V)	I _e	A	¹⁾ 10		¹⁾ 10 / ²⁾ 12	
Maximum operating frequency for AC-5b		op./h	600			450
Electrical endurance for AC-5b		op. c.	¹⁾ 100.000 / ²⁾ 60.000 / ³⁾ 20.000			

GENERAL

MAIN CIRCUIT

TECHNICAL DATA

BISTABLE SWITCHES - UP TO 32 A

Type	Symbol	Unit	BI416	BI420 BI820	BI425 BI825	BI432 BI832
Rated operational current for AC-6a (at 230 V)	I_e	A	2.8	3	3.6	4.5
Maximum operating frequency for AC-6a		op./h	600		450	
Electrical endurance for AC-6a		op. C.	100,000			
Switching of capacitors AC-6b and AC-7c (at 230 V)	C	μ F	80	100	120	150
Maximum operating frequency for AC-6b and AC-7c		op./h	600		450	
Electrical endurance for AC-6b and AC-7c		op. C.	100,000			
Rated operational current for DC-1 (L/R \leq 1 ms):						
1 pole ... 24 V DC/48 V DC/60 V DC/110 V DC/ 220 V DC	I_e	A	16/12/8/4/0.4	20/15/10/5/0.5	25/20/15/6/0.6	32/25/20/7/0.7
2 poles in series ... 24 V DC/48 V DC/60 V DC/110 V DC/ 220 V DC			16/15/14/7/3	20/18/15/8/4	25/25/20/10/5	32/28/22/12/6
3 poles in series ... 24 V DC/48 V DC/60 V DC/110 V DC/ 220 V DC			16/16/16/16/10	20/20/20/18/12	25/25/25/20/15	32/32/28/22/18
4 poles in series ... 24 V DC/48 V DC/60 V DC/110 V DC/ 220 V DC			16/16/16/16/13	20/20/20/20/15	25/25/25/22/18	32/32/32/25/20
Maximum operating frequency for DC-1		op./h	300			
Electrical endurance for DC-1		op. C.	100,000			
Rated operational current for DC-3 (L/R \leq 2 ms):						
1 pole ... 24 V DC/48 V DC/60 V DC/110 V DC/ 220 V DC	I_e	A	9/4/2/1/0.1	10/5/2/1/0.1	15/8/3/1.1/0.2	18/10/4/1.2/0.3
2 poles in series ... 24 V DC/48 V DC/60 V DC/110 V DC/ 220 V DC			16/9/7/3/0.3	20/10/8/3/0.4	25/16/12/4/0.6	32/18/14/5/0.8
3 poles in series ... 24 V DC/48 V DC/60 V DC/110 V DC/ 220 V DC			16/16/16/8/1	20/20/20/10/2	25/25/25/15/3	32/30/28/18/4
4 poles in series ... 24 V DC/48 V DC/60 V DC/110 V DC/ 220 V DC			16/16/16/13/4	20/20/20/15/6	25/25/25/20/8	32/32/30/22/10
Maximum operating frequency for DC-3		op./h	300			
Electrical endurance for DC-3		op. C.	100,000			
Rated operational current for DC-5 (L/R \leq 7.5 ms):						
1 pole ... 24 V DC/48 V DC/60 V DC/110 V DC/ 220 V DC	I_e	A	9/3/1/0.3/0.05	10/4/1/0.3/0.05	15/5/2/0.5/0.08	18/6/3/0.8/0.1
2 poles in series ... 24 V DC/48 V DC/60 V DC/110 V DC/ 220 V DC			16/7/5/1.5/0.1	20/8/6/2/0.2	25/15/10/3/0.4	32/16/12/4/0.6
3 poles in series ... 24 V DC/48 V DC/60 V DC/110 V DC/ 220 V DC			16/16/15/6/0.5	20/20/18/8/1	25/25/20/12/2	32/28/25/16/3
4 poles in series ... 24 V DC/48 V DC/60 V DC/110 V DC/ 220 V DC			16/16/16/10/1.5	20/20/20/12/3	25/25/25/15/5	32/30/28/18/8
Maximum operating frequency for DC-5		op./h	300			
Electrical endurance for DC-5		op. C.	100,000			
Terminal capacity:						
rigid (solid and stranded)	S	mm ²	1 ... 10			
flexible			1 ... 10			
Length of removed wire insulation		mm	9			
Screw			M4			
Screw head			PZ2			
Tightening torque		Nm	1.2			
Range of control voltage for switch-on	U_c	%	90 ... 110			
Range of control voltage for drop out	U_c	%	75 ... 20			
Kind of voltage			AC			
Standard control voltages	U_c	V	8, 12, 24, 48, 120, 230, 240			
Frequency of AC control voltage	f	Hz	50 or 60			
Control mode			remote control with impulse voltage / manual control			
Impulse duration of control voltage:						
minimum			50 ms			
optimum - recommended			100 ... 500 ms			
maximum (only in case of breakdown of control system)			1 hour			
Minimum duration between two impulses of control voltage		ms	150			
Surge immunity withstand voltage 1.2/50 μ s acc. to standard IEC/EN 61000-4-5		kV	3			
Coil consumption:						
switch-on	VA/W		18/13			
operation			9/4			
Delays:						
make	ms		5 ... 20			
brake			5 ... 20			
Terminal capacity:						
rigid (solid and stranded)	mm ²		1 ... 4			
flexible			1 ... 4			
Length of removed wire insulation		mm	7			
Screw			M3			
Screw head			PZ1			
Tightening torque		Nm	0.6			

MAIN CIRCUIT

COIL

4

TECHNICAL DATA

BISTABLE SWITCHES - UP TO 32 A

SAFETY

Type	Symbol	Unit	BI416	BI420 BI820	BI425 BI825	BI432 BI832
MTTF - Mean time to failure $MTTF = 1/\lambda = B10/(0.1 n_{op})$		h		4.166		
MTTF _d - Mean time to failure dangerous $MTTF_d = 1/\lambda_d = B10_d/(0.1 n_{op})$		h		8.333		
B10 - Number of operating cycles until 10 % of devices fail		op. c.		50.000		
B10 _d - Number of operating cycles until 10 % of device dangerous $B10_d = B10/\text{ratio of dangerous failures}$		op. c.		100.000		
λ - Failure rate $\lambda = (0.1 n_{op})/B10$		1/h		0.00024		
λ_d - Failure rate dangerous $\lambda_d = (0.1 n_{op})/B10_d$		1/h		0.00012		
Ratio of dangerous failures		%		50		
n_{op} - Operating cycles (operating cycles/h)		op. c./h		120		

4

Mounting positions of accessories

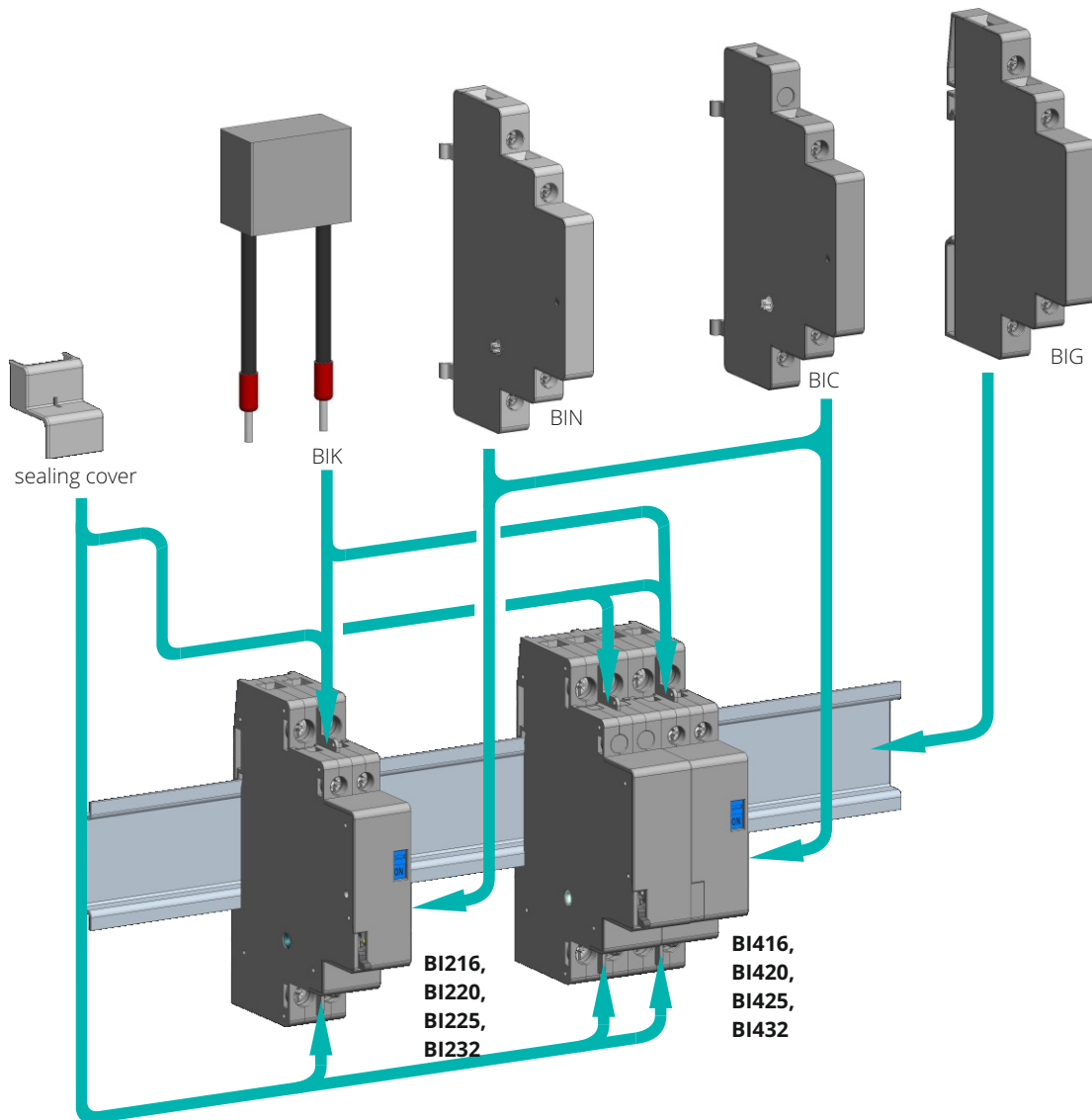

TECHNICAL DATA

LATCHED CONTACTORS - UP TO 80 A

Type	Symbol	Unit	BI240	BI263	BI280	BI440	BI463	BI480
Standards			IEC/EN 61095, IEC/EN 60947-4-1					
Approvals			CE, CB					
Module width			4					
Number of poles			4					
Degree of protection			IP20					
Pollution degree			3					
Climatic conditions			95 % relative humidity					
Ambient temperature (open)		°C	-25 ... +55 (>55 ... +70 at max. impulse duration which is 1 min)					
Storage temperature		°C	-30... +80					
Maximum altitude		m	2000					
U_i and U_e is reduced for 1.2 % and I_e for 0.4 % for every additional 100 m								
Number of contactors or switches side-by-side:			no limitation					
≤40 °C			no limitation					
(40 ... 55) °C			no limitation	max. 6	no limitation	no limitation	max. 3	
(55 ... 70) °C			max. 4	max. 2	max. 2	max. 2	max. 1	
Noise level (operation)		dB	0 (coil voltage is switched off)					
Vibration resistance according to IEC/EN 60068-2-6	a	g	3 (Z axis)					
Shock resistance according to IEC/EN 6068-2-27	a	g	15 (Z axis)					
Maximum operating frequency with no load		op. c./h	450					
Mechanical endurance		op. c.	1.000.000					
Weight		g	265			400		
Contact reliability			≥10 V; ≥100 mA					
Minimum distance of open contacts		mm	>3					
Power dissipation per pole		W	3	3.5	4	3	3.5	4
Overload current withstand capability:								
10 s		A	176	240	304	176	240	304
5 s		A	240	300	350	240	300	350
1 s		A	300	360	400	300	360	400
0.001 s		A	500	650	800	500	650	800
Maximum back-up fuse for short-circuit protection gL and gG: coordination type 1 (at prospective current 3 kA)	I_v	A	40	63	80	40	63	80
Rated insulation voltage	U_i	V	440					
Rated impulse withstand voltage	U_{imp}	kV	4					
Rated operational voltage	U_e	V	400					
Rated frequency	f	Hz	50/60					
Thermal current	I_{th}	A	40	63	80	40	63	80
Rated operational current for AC-1, AC-7a and AC-21	I_e	A	40	63	80	40	63	80
Operational power for AC-1, AC-7a and AC-21:								
single-phase 230 V	P_e	kW	8.8	13.8	17.5	8.8	13.8	17.5
three-phase 230 V						15.1	23.8	30.2
three-phase 400 V						26.3	41.5	52.5
Maximum operating frequency for AC-1, AC-7a and AC-21		op. c./h	360					
Electrical endurance for AC-1, AC-7a and AC-21		op. c.	100.000					
Rated operational current for AC-2	I_e	A	25	32	40	25	32	40
Operational power for AC-2:								
single-phase 230 V	P_e	kW	3.7	4.8	6	3.7	4.8	6
three-phase 230 V						6.5	8.3	10.3
three-phase 400 V						11.2	14.4	18
Maximum operating frequency for AC-2		op. c./h	120					
Electrical endurance for AC-2		op. c.	100.000					
Rated operational current for AC-3, AC-7b and AC-23	I_e	A	22	30	38	22	30	38
Operational power for AC-3, AC-7b and AC-23:								
single-phase 230 V	P_e	kW	2.2	3.7	4	2.2	3.7	4
three-phase 230 V						5.5	7.5	11
three-phase 400 V						11	15	18.5
Maximum operating frequency for AC-3, AC-7b and AC-23		op. c./h	360					
Electrical endurance for AC-3, AC-7b and AC-23		op. c.	100.000					
Rated operational current for AC-5a (at 230 V)	I_e	A	25	32	36	25	32	36
Maximum operating frequency for AC-5a		op. c./h	360					
Electrical endurance for AC-5a		op. c.	100.000					
Rated operational current for AC-5b (at 230 V)	I_e	A	25	32	36	25	32	36
Maximum operating frequency for AC-5b		op. c./h	360					
Electrical endurance for AC-5b		op. c.	100.000					

LATCHED CONTACTORS - UP TO 80 A

Type	Symbol	Unit	BI240	BI263	BI280	BI440	BI463	BI480
Rated operational current for AC-6a (at 230 V)	I_e	A	10	16	20	10	16	20
Maximum operating frequency for AC-6a	op. c./h				360			
Electrical endurance for AC-6a	op. C.				100,000			
Switching of capacitors AC-6b and AC-7c (at 230 V)	C	μ F	220	330	360	220	330	360
Maximum operating frequency for AC-6b and AC-7c	op. c./h				360			
Electrical endurance for AC-6b and AC-7c	op. C.				100,000			
Rated operational current for DC-1 (L/R \leq 1 ms):								
1 pole ... 24 V DC/48 V DC/60 V DC/110 V DC/ 220 V DC	I_e	A	40/30/25/8/1	63/35/30/10/1.2		40/30/25/8/1	63/35/30/10/1.2	
2 poles in series ... 24 V DC/48 V DC/60 V DC/110 V DC/ 220 V DC			40/38/32/14/8	63/42/34/16/10		40/38/32/14/8	63/42/34/16/10	
3 poles in series ... 24 V DC/48 V DC/60 V DC/110 V DC/ 220 V DC						40/40/40/30/20	63/63/60/35/30	
4 poles in series ... 24 V DC/48 V DC/60 V DC/110 V DC/ 220 V DC						40/40/40/40/40	63/63/63/63/63	
Maximum operating frequency for DC-1	op. c./h				300			
Electrical endurance for DC-1	op. C.				100,000			
Rated operational current for DC-3 (L/R \leq 2 ms):								
1 pole ... 24 V DC/48 V DC/60 V DC/110 V DC/ 220 V DC	I_e	A	22/11/6/1.5/0.4	25/12/7/2/0.5		22/11/6/1.5/0.4	25/12/7/2/0.5	
2 poles in series ... 24 V DC/48 V DC/60 V DC/110 V DC/ 220 V DC			40/20/16/6/1	45/22/18/7/1.2		40/20/16/6/1	45/22/18/7/1.2	
3 poles in series ... 24 V DC/48 V DC/60 V DC/110 V DC/ 220 V DC						40/40/32/20/5	63/45/35/22/6	
4 poles in series ... 24 V DC/48 V DC/60 V DC/110 V DC/ 220 V DC						40/40/40/40/12	63/63/63/63/15	
Maximum operating frequency for DC-3	op. c./h				300			
Electrical endurance for DC-3	op. C.				100,000			
Rated operational current for DC-5 (L/R \leq 7.5 ms):								
1 pole ... 24 V DC/48 V DC/60 V DC/110 V DC/ 220 V DC	I_e	A	25/8/4/1/0.15	30/10/5/1.2/0.2		25/8/4/1/0.15	30/10/5/1.2/0.2	
2 poles in series ... 24 V DC/48 V DC/60 V DC/110 V DC/ 220 V DC			40/18/14/5/0.8	45/50/15/6/1		40/18/14/5/0.8	45/50/15/6/1	
3 poles in series ... 24 V DC/48 V DC/60 V DC/110 V DC/ 220 V DC						40/40/28/18/4	63/44/30/20/5	
4 poles in series ... 24 V DC/48 V DC/60 V DC/110 V DC/ 220 V DC						40/40/40/35/10	63/63/60/45/12	
Maximum operating frequency for DC-5	op. c./h				300			
Electrical endurance for DC-5	op. C.				100,000			
Terminal capacity:								
rigid (solid and stranded)	S	mm ²			2.5 ... 25			
flexible					2.5 ... 25			
Length of removed wire insulation		mm			11			
Screw					M5			
Screw head					PZ2			
Tightening torque		Nm			2.0			
Range of control voltage for switch-on	U_c	%			85 ... 110			
Range of control voltage for drop out	U_c	%			75 ... 20			
Kind of voltage					AC			
Standard control voltages	U_c	V			8, 12, 24, 48, 120, 230, 240			
Frequency of AC control voltage	f	Hz			50 or 60			
Control mode					remote control with impulse voltage / manual control			
Impulse duration of control voltage:								
minimum					50 ms			
optimum - recommended					100 ... 500 ms			
maximum (only in case of breakdown of control system)					1 hour			
Minimum duration between two impulses of control voltage		ms			150			
Surge immunity withstand voltage 1.2/50 μ s acc. to standard IEC/EN 61000-4-5		kV			2			
Coil consumption:								
switch-on		VA/W			26/12			
operation					12/4			
Delays:								
make		ms			5 ... 20			
brake					5 ... 20			
Terminal capacity:								
rigid (solid and stranded)		mm ²			1 ... 4			
flexible					1 ... 4			
Length of removed wire insulation		mm			7			
Screw					M3			
Screw head					PZ1			
Tightening torque		Nm			0.6			

LATCHED CONTACTORS - UP TO 80 A

Type	Symbol	Unit	BI240	BI263	BI280	BI440	BI463	BI480
MTTF - Mean time to failure $MTTF = 1/\lambda = B10/(0.1 n_{op})$		h				1.388		
MTTF _d - Mean time to failure dangerous $MTTF_d = 1/\lambda_d = B10_d/(0.1 n_{op})$		h				2.777		
B10 - Number of operating cycles until 10 % of devices fail		op. c.				50.000		
B10 _d - Number of operating cycles until 10 % of device dangerous $B10_d = B10/\text{ratio of dangerous failures}$		op. c.				100.000		
λ - Failure rate $\lambda = (0.1 n_{op})/B10$		1/h				0.00072		
λ_d - Failure rate dangerous $\lambda_d = (0.1 n_{op})/B10_d$		1/h				0.00036		
Ratio of dangerous failures		%				50		
n_{op} - Operating cycles (operating cycles/h)		op. c./h				360		

SAFETY

4

Mounting positions of accessories

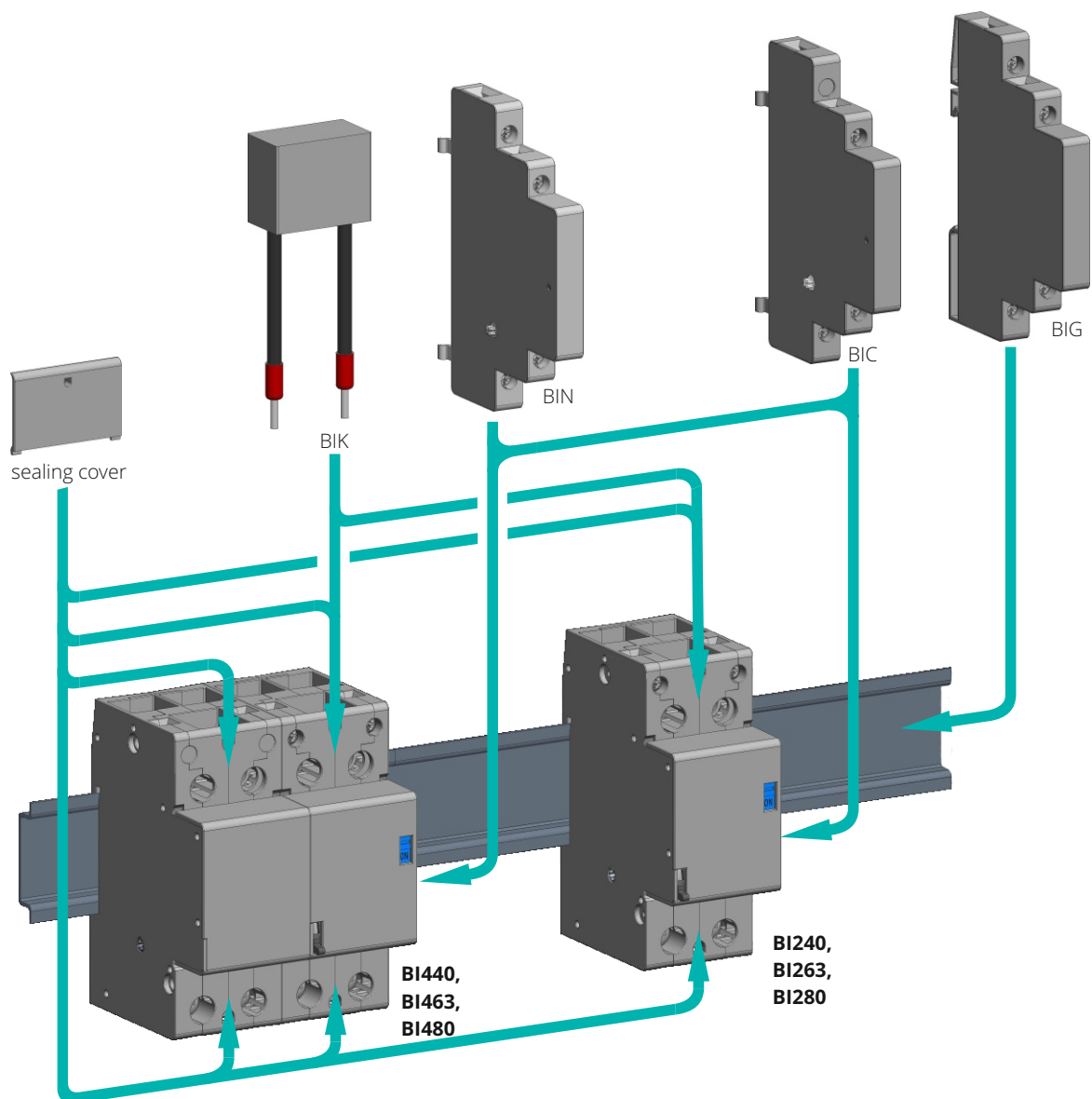

TECHNICAL DATA

BIN - Auxiliary switch

BENEFITS

- Reliable switching
- Allows remote indication
- Different versions of contacts
- Compatible with the entire range of bistable switches
- Easy to fit on right side of the bistable switch
- Simple and strong fixing with screw

WIRING DIAGRAM

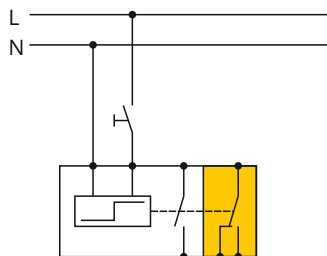

BIC - Auxiliary device for centralised control

BENEFITS

- For centralised control
- Control by a single command
- Possible to actuate over a time switch
- Each bistable switch with BIC may be independant of local push-button controlled via remote push-buttons ON and OFF
- Compatible with the entire range of bistable switches
- Simple and strong fixing with screw

NOTE: Suitable for AC control systems

WIRING DIAGRAM

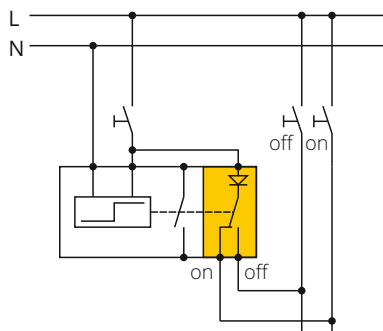

BIG - Auxiliary device for group control

BENEFITS

- For group control
- Saving space construction
- Quick assembly to 35 mm wide mounting rail

Maximum number of bistable switches that can be controlled:

- 230 V AC: 20
- 120 V AC: 10
- 48 V AC: 5
- 24 V AC: 2
- 12 V AC: 1

NOTE: Suitable for AC control systems

WIRING DIAGRAM

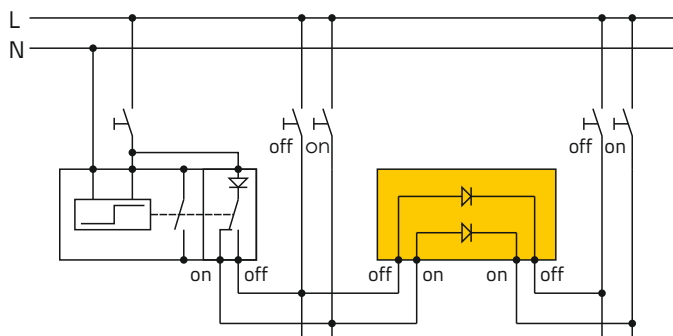

BIK - Compensation capacitor

BENEFITS

- Increase the number of illuminated push-buttons
- After the installation is not visible from the cabinet
- Independent unit

USE

For operations of bistable switches without malfunctions when illuminated push-buttons are used. Compensation capacitors parallel to the coil of bistable switch increases the powerconsumption of 230 V 50 Hz illuminated push-buttons from 2.5 mA to 20 mA.

BISTABLE SWITCHES - ACCESSORIES

4

	Type	Symbol	Unit	BIN	BIC	BIG
GENERAL	Standards				IEC/EN 60947-5-1	
	Approvals				CE	
	Module width				1/2 (9 mm)	
	Number of poles			2		
	Degree of protection				IP20	
	Pollution degree				3	
	Climatic conditions				95 % relative humidity	
	Ambient temperature (open)		°C		-25 ... +70	
	Storage temperature		°C		-30... +80	
	Maximum altitude		m		2000	
	U _i and U _e is reduced for 1.2 % and I _e for 0.4 % for every additional 100 m					
	Vibration resistance according to IEC/EN 60068-2-6	a	g		3 (Z axis)	
	Shock resistance according to IEC/EN 60068-2-27	a	g		15 (Z axis)	
	Mechanical endurance		op. c.		1.000.000	
Weight		g		30		
AUXILIARY CIRCUIT	Contact reliability			≥12 V; ≥5 mA		
	Minimum distance of open contacts		mm	>3		
	Power dissipation per pole		W	0.3		
	Maximum back-up fuse for short-protection gL and gG: coordination type 1 (at prospective current 3 kA)	I _v	A	6		
	Rated insulation voltage	U _i	V	440		
	Rated impulse withstand voltage	U _{imp}	kV	4		
	Rated operational voltage	U _e	V	250		
	Rated frequency	f	Hz	50/60		
	Thermal current	I _{th}	A	6		
	Rated operational current for AC-15: single-phase 230 V	I _e	A	4		
	Maximum operating frequency for AC-15		op. c./h	360		
	Electrical endurance for AC-15		op. c.	100.000		
	Terminal capacity: rigid (solid and stranded)	S	mm ²	1 ... 4		
	flexible			1 ... 4		
	Length of removed wire insulation		mm	7		
	Screw			M3		
	Screw head			PZ1		
Tightening torque		Nm	0.8			
SAFETY	MTTF - Mean time to failure MTTF = 1/λ = B10/(0.1 n _{op})		h	1.388		
	MTTF _d - Mean time to failure dangerous MTTF _d = 1/λ _d = B10 _d /(0.1 n _{op})		h	2.777		
	B10 - Number of operating cycles until 10 % of devices fail		op. c.	50.000		
	B10 _d - Number of operating cycles until 10 % of device dangerous		op. c.	100.000		
	B10 _d = B10/ratio of dangerous failures					
	λ - Failure rate λ = (0.1 n _{op})/B10		1/h	0.00072		
	λ _d - Failure rate dangerous λ _d = (0.1 n _{op})/B10 _d		1/h	0.00036		
	Ratio of dangerous failures		%	50		
	n _{op} - Operating cycles (operating cycles/h)		op. c./h	360		

TECHNICAL DATA

BISTABLE SWITCHES WITH A COMMUNICATIONS - BICOM

Type	Symbol	Unit	BICOM420	BICOM425	BICOM432
Standards			IEC/EN 60669-2-2		
Approvals			CE		
Module width			2		
Number of poles			4		
Degree of protection			IP20		
Pollution degree			3		
Climatic conditions			95 % relative humidity		
Ambient temperature (open)		°C	-25 ... +55		
Storage temperature		°C	-30... +80		
Maximum altitude		m	2000		
U _i and U _e is reduced for 1.2 % and I _e for 0.4 % for every additional 100 m					
Number of contactors or switches side-by-side: ≤40 °C			no limitation		
(40 ... 55) °C			max. 3		
Noise level (operation)		dB	0 (between changing positions)		
Maximum operating frequency with no load		op. c./h	900	450	
Mechanical endurance		op. c.	1.000.000		
Weight		g	220		
Contact reliability			≥10 V; ≥100 mA		
Minimum distance of open contacts		mm	>3		
Power dissipation per pole		W	1.5	2	3
Overload current withstand capability: 10 s		A	56	68	96
Maximum back-up fuse for short-circuit protection gL and gG: coordination type 1 (at prospective current 3 kA)	I _v	A	20	25	32
Rated insulation voltage	U _i	V	440		
Rated impulse withstand voltage	U _{imp}	kV	4		
Rated operational voltage	U _e	V	400		
Rated frequency	f	Hz	50/60		
Thermal current	I _{th}	A	20	25	32
Rated operational current for cos φ= 0.6 acc. to IEC/EN 60669-2-2		A	20	25	32
Max. operating frequency for cos φ= 0.6 acc. to IEC/EN 60669-2-2		op. c./h	900	450	
Electrical endurance for cos φ= 0.6 acc. to IEC/EN 60669-2-2		op. c.	100.000		
Rated operational current for AC-1, AC-7a and AC-21	I _e	A	20	25	32
Operational power for AC-1, AC-7a and AC-21: single-phase 230 V	P _e	kW	8.8	5.5	7
three-phase 230 V			7.6	9.5	12.1
three-phase 400 V			13.2	16.5	21
Maximum operating frequency for AC-1, AC-7a and AC-21		op. c./h	900	450	
Electrical endurance for AC-1, AC-7a and AC-21		op. c.	100.000		
Rated operational current for AC-2	I _e	A	10	13	16
Operational power for AC-2: single-phase 230 V	P _e	kW	1.5	2	2.4
three-phase 230 V			2.6	3.3	4.1
three-phase 400 V			4.5	5.8	7.2
Maximum operating frequency for AC-2		op. c./h	120		
Electrical endurance for AC-2		op. c.	100.000		
Rated operational current for AC-3, AC-7b and AC-23	I _e	A	7	8.5	12
Operational power for AC-3, AC-7b and AC-23: single-phase 230 V	P _e	kW	0.5	0.75	1.1
three-phase 230 V			1.5	2.2	3
three-phase 400 V			3	4	5.5
Maximum operating frequency for AC-3, AC-7b and AC-23		op. c./h	600	450	
Electrical endurance for AC-3, AC-7b and AC-23		op. c.	100.000		
Rated operational current for AC-5a (at 230 V)	I _e	A	16		
Maximum operating frequency for AC-5a		op. c./h	600	450	
Electrical endurance for AC-5a		op. c.	100.000		
Rated operational current for AC-5b (at 230 V)	I _e	A	¹ 10	¹ 10 / ² 12	¹ 10 / ² 16
Maximum operating frequency for AC-5b		op. c./h	600	450	
Electrical endurance for AC-5b		op. c.	¹ 100.000 / ² 60.000 / ³ 20.000		

GENERAL

MAIN CIRCUIT

BISTABLE SWITCHES WITH A COMMUNICATIONS - BICOM

4

Type	Symbol	Unit	BICOM420	BICOM425	BICOM432
Rated operational current for AC-6a (at 230 V)	I_e	A	3	3.6	4.5
Maximum operating frequency for AC-6a		op./h	600		450
Electrical endurance for AC-6a		op. C.		100.000	
Switching of capacitors AC-6b and AC-7c (at 230 V)	C	μ F	100	120	150
Maximum operating frequency for AC-6b and AC-7c		op./h	600		450
Electrical endurance for AC-6b and AC-7c		op. C.		100.000	
Rated operational current for DC-1 (L/R \leq 1 ms):					
1 pole ... 24 V DC/48 V DC/60 V DC/110 V DC/ 220 V DC	I_e	A	20/15/10/5/0.5	25/20/15/6/0.6	32/25/20/7/0.7
2 poles in series ... 24 V DC/48 V DC/60 V DC/110 V DC/ 220 V DC			20/18/15/8/4	25/25/20/10/5	32/28/22/12/6
3 poles in series ... 24 V DC/48 V DC/60 V DC/110 V DC/ 220 V DC			20/20/20/18/12	25/25/25/20/15	32/32/28/22/18
4 poles in series ... 24 V DC/48 V DC/60 V DC/110 V DC/ 220 V DC			20/20/20/20/15	25/25/25/22/18	32/32/32/25/20
Maximum operating frequency for DC-1		op./h		300	
Electrical endurance for DC-1		op. C.		100.000	
Rated operational current for DC-3 (L/R \leq 2 ms):					
1 pole ... 24 V DC/48 V DC/60 V DC/110 V DC/ 220 V DC	I_e	A	10/5/2/1/0.1	15/8/3/1.1/0.2	18/10/4/1.2/0.3
2 poles in series ... 24 V DC/48 V DC/60 V DC/110 V DC/ 220 V DC			20/10/8/3/0.4	25/16/12/4/0.6	32/18/14/5/0.8
3 poles in series ... 24 V DC/48 V DC/60 V DC/110 V DC/ 220 V DC			20/20/20/10/2	25/25/25/15/3	32/30/28/18/4
4 poles in series ... 24 V DC/48 V DC/60 V DC/110 V DC/ 220 V DC			20/20/20/15/6	25/25/25/20/8	32/32/30/22/10
Maximum operating frequency for DC-3		op./h		300	
Electrical endurance for DC-3		op. C.		100.000	
Rated operational current for DC-5 (L/R \leq 7.5 ms):					
1 pole ... 24 V DC/48 V DC/60 V DC/110 V DC/ 220 V DC	I_e	A	10/4/1/0.3/0.05	15/5/2/0.5/0.08	18/6/3/0.8/0.1
2 poles in series ... 24 V DC/48 V DC/60 V DC/110 V DC/ 220 V DC			20/8/6/2/0.2	25/15/10/3/0.4	32/16/12/4/0.6
3 poles in series ... 24 V DC/48 V DC/60 V DC/110 V DC/ 220 V DC			20/20/18/8/1	25/25/20/12/2	32/28/25/16/3
4 poles in series ... 24 V DC/48 V DC/60 V DC/110 V DC/ 220 V DC			20/20/20/12/3	25/25/25/15/5	32/30/28/18/8
Maximum operating frequency for DC-5		op./h		300	
Electrical endurance for DC-5		op. C.		100.000	
Terminal capacity:					
rigid (solid and stranded)	S	mm ²		1 ... 10	
flexible				1 ... 10	
Length of removed wire insulation		mm		9	
Screw				M4	
Screw head				PZ2	
Tightening torque		Nm		1.2	
Range of control voltage for switch-on	U_c	%		90 ... 110	
Kind of voltage				AC	
Standard control voltages	U_c	V		110, 120, 220, 230, 240	
Frequency of AC control voltage	f	Hz		50 or 60	
Control mode				communication / manual control	
Communication				IR, CAN, MODBUS, or I/O	
LED status				WM1, CAN, MODBUS: continuous light: normal operation / interrupted light: contact error	
Coil consumption:					
switch-on		VA/W		20/15	
operation - electric circuit				0.7/0.5	
Delays:					
make		ms		<250	
brake				<250	
Connection of communication				CAN, MODBUS, I/O: 4-pin connector WM1: window on left side (IR)	
Terminal capacity of A1 and A2:					
rigid (solid and stranded)		mm ²		1 ... 4	
flexible				1 ... 4	
Length of removed wire insulation		mm		7	
Screw				M3	
Screw head				PZ1	
Tightening torque		Nm		0.6	

MAIN CIRCUIT

COIL

TECHNICAL DATA

BISTABLE SWITCHES - OPERATION POSITION, DIMENSIONS

Operation position

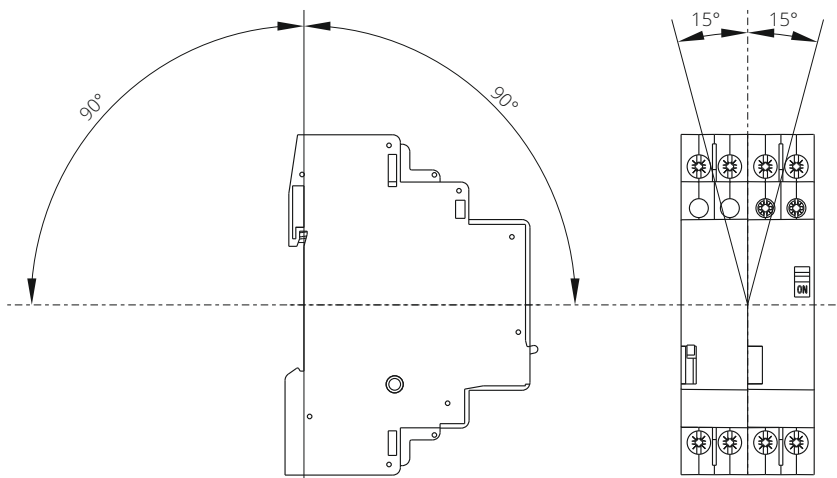

4

**BI216, BI220
BI225, BI232**

**BI416, BI420, BI425
BI432, BICOM**

BICOM-WM1

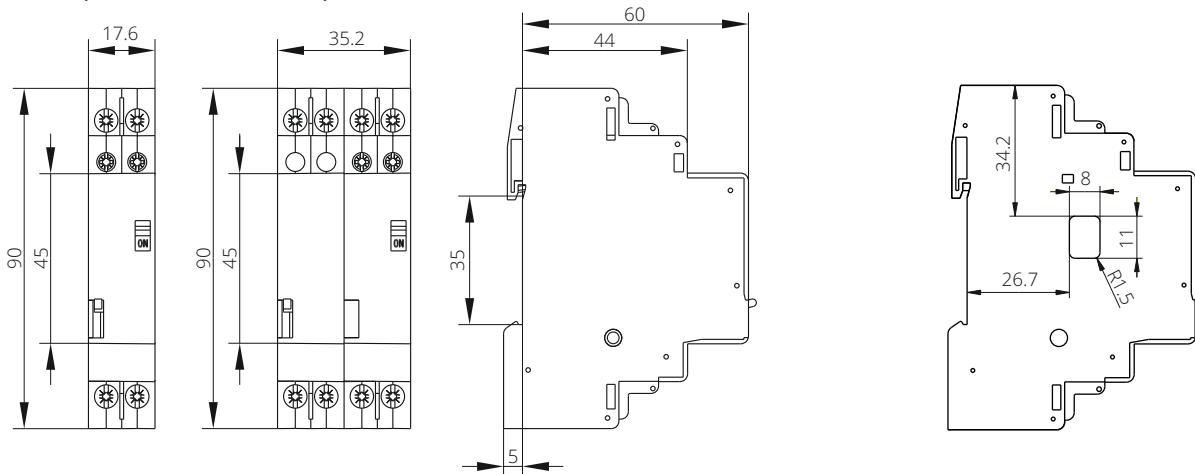

**BI240, BI263
BI280**

**BI440, BI463
BI480**

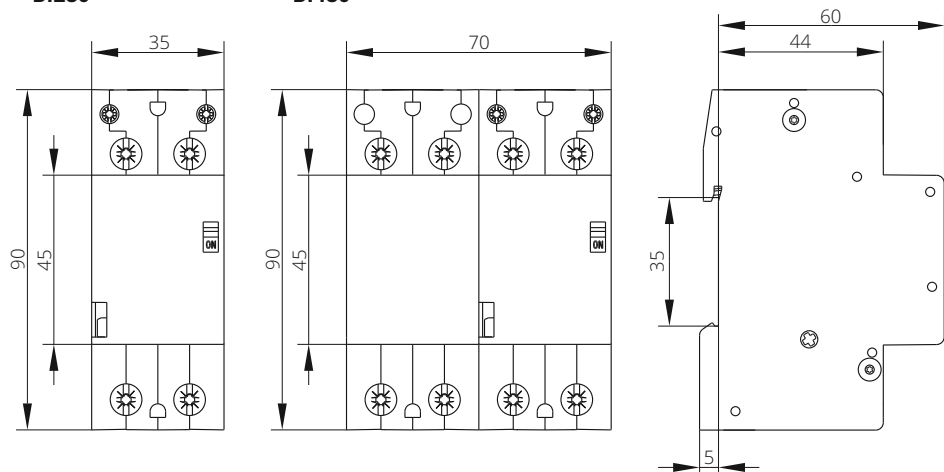

DIMENSIONS

BISTABLE SWITCHES - DIMENSIONS

BI820, BI825
BI832

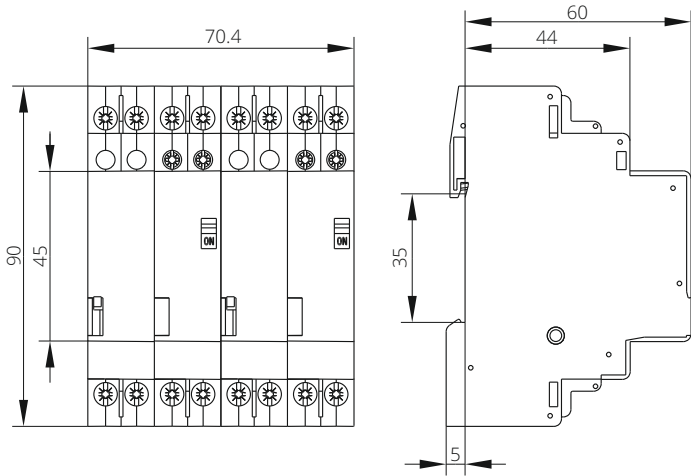

BIN, BIC

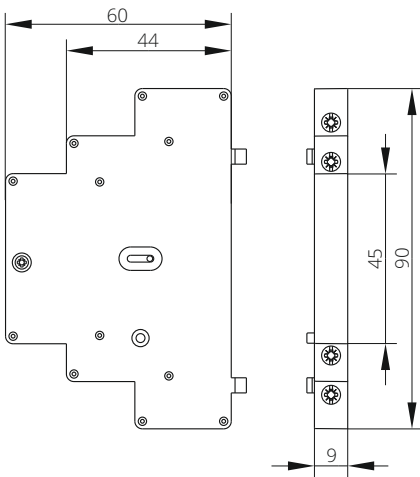

BIG

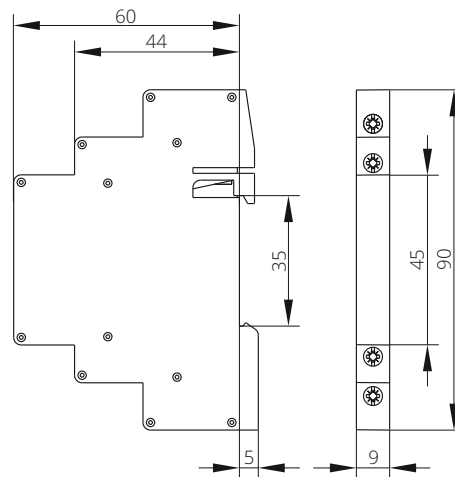

BISTABLE SWITCHES - CONNECTIONS

Scheme for connection BIG, BIC and bistable switches in level

