

Low Voltage Power Factor Corrections



Capacitors

 **Iskra**[®]
Iskra Kondenzatorji

Contents

General information on Iskra Capacitors

Type	Page
Introduction	4
1. Single-phase capacitor type KNK5015 230...550 V, 1,67...5 kvar	6
2. Three-phase capacitors in aluminium housing KNK5065 400...525 V, 2,5...5 kvar	8
3. Three-phase capacitors in aluminium housing KNK6049 400...525 V, 10...25 kvar	9
4. Three-phase capacitors in aluminium housing KNK9053 380...525 V, 10...25 kvar	11
5. Three-phase capacitors KNK9103 and KNK9143 230...550 V, 5...60 kvar	14
6. Single-phase capacitors KNK9101 and KNK9141 230...550 V, 5...60 kvar	18
Basic of power factor correction	20

Applications

The KNK capacitors are used for power factor correction of inductive consumers (transformers, electric motors, rectifiers) in industrial networks for voltages of up to 660 V.

Design

Cylindrical aluminium housing with metallized three-layer polypropylene film dielectric, especially treated for better contact. The capacitors are impregnated with a vegetable oil which is PCB-free and biologically degradable.

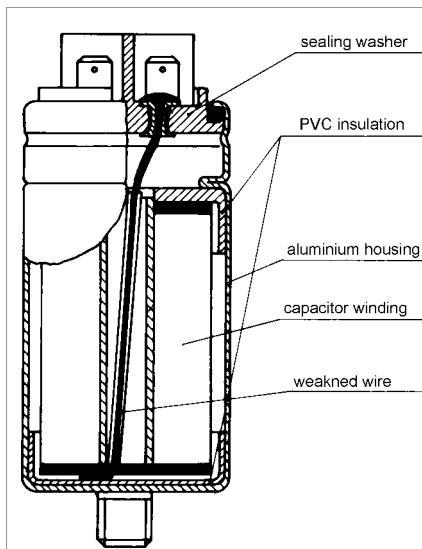
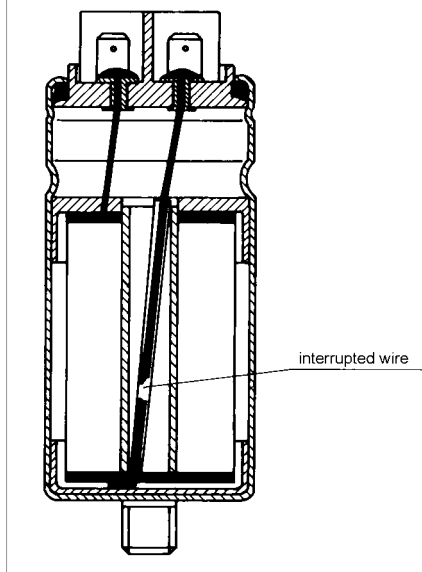

Figure 1



Self-Healing Capacity

Damage may occur on the dielectric due to fatigue which results in local breakdowns on certain points. The resultant electric current devaporises the thin metallized layer and isolates the damaged spot from the rest of the capacitor. Capacitance loss is almost negligible (some pF) during this process. This self-healing property guarantees operating reliability and long life expectancy of the capacitor.

Self-healing of KNK capacitors

1. metallized layer
2. polypropylene film
3. breakdown point
4. devaporised metallized layer

Figure 2

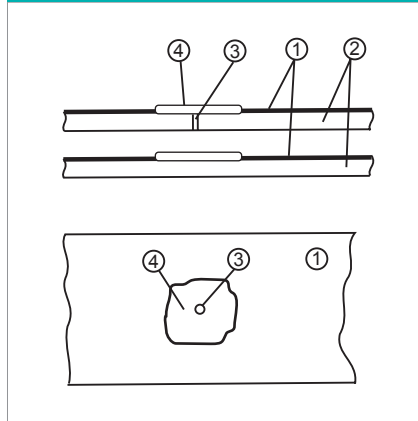

Discharge Resistor

Every capacitor incorporates a resistor which serves for capacitor discharging after network disconnection to 75 V in 3 minutes.

Over-Pressure Disconnecter

Every capacitor incorporates a mechanical over-pressure disconnecter which disconnects the capacitor in case of overloading or other internal damages. Operation is shown in figure 1.

Routine Testing of Capacitors

Capacitors are subjected to the following tests during the production process:

- sealing test (90 °C, 6 hrs)
- voltage tests between layers with AC voltage equal to $2,15 \times U_n$, 2 s
- voltage test between layers and the housing with AC voltage 3600 V, 2 s
- measurement of loss angle $\tan\delta$ at a rated voltage, frequency of 50 Hz, and room temperature
- measurement of capacitance at a rated voltage, frequency of 50 Hz, and room temperature

Available Versions of KNK Capacitors

Indoor mounting:

- KNK5015 - Single-phase in cylindrical housing
- KNK5065 - three-phase in cylindrical housing
- KNK6049 - three-phase in cylindrical housing
- KNK9053 - three-phase in cylindrical housing
- KNK9101 - single-phase in a prism shaped housing
- KNK9103 - three-phase in a prism shaped housing
- KNK9141 - single-phase with cap in a prism shaped housing (IP 55)
- KNK9143 - three-phase with cap in a prism shaped housing (IP 55)
- KNK9151 - single-phase with cap in a prism shaped housing (IP 40)
- KNK9153 - three-phase with cap in a prism shaped housing (IP 40)

Notes:

On request, capacitors with other power and voltage ratings, shapes, and connections are available.

- All rights reserved for any possible changes.
- In-rush current must be limited to maximal permitted value.

Ordering:

- capacitor type
- capacitor power
- rated voltage
- rated frequency
- quantity and delivery terms

Ordering example for three-phase 50 kvar capacitor of 400 V:

KNK9103 50 kvar, 400 V, 50 Hz.

TECHNICAL DATA

Rated voltage U_n :	see table
Rated frequency:	50 Hz or 60 Hz
Capacitance tolerance:	- 5 % to + 15 %
Losses: - dielectric: - total:	< 0,2 W/kvar < 0,5 W/kvar
Standards:	IEC Publ. 60831 - 1/2
Safety:	self-healing, overpressure disconnecter
Dielectric:	metallized polypropylene film; sealed with plant oil, PCB-free
Permitted ambient temperature:	- 25 °C to + 55 °C, other on request
Permitted storage temperature:	- 40 °C to + 70 °C
Permitted overload:	1,1 × U_n (8 h per day) 1,3 × I_n (rated current)
In-rush current:	100 × I_n max.
Test conditions:	- between layers 2,15 × U_n , AC, 2 s - layers-housing 3,6 kV, AC, 2 s
Max. weight per kvar:	cylindrical housing: 0,1 kg prism shaped housing: 0,3 kg

1. Single-phase capacitor KNK5015

Figure 3

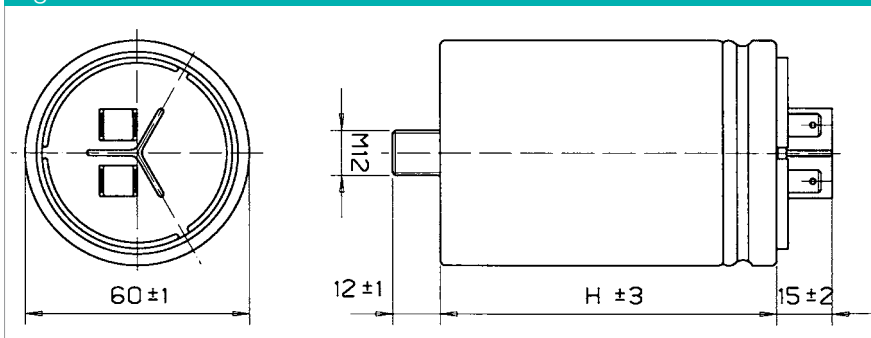

Single-phase capacitor KNK5015, 50 Hz

U_n (V)	Q_n (kvar)	C_n (μ F)	I_n (A)	H (mm)	Weight (kg)	Packing unit (pcs)
230	1,67	100	7,2	125	0,40	36
230	2,1	126	9,1	150	0,45	36
400	1,67	33,2	4,2	75	0,22	36
400	2,1	41,6	5,2	87	0,27	36
400	2,5	49,7	6,2	87	0,27	36
400	3,33	66,3	8,3	110	0,32	36
400	4,17	82,9	10,4	125	0,40	36
400	5	99,5	12,5	150	0,45	36
415	1,67	30,8	4	75	0,22	36
415	2,5	46,2	6	87	0,27	36
415	3,33	61,2	8	110	0,32	36
415	4,17	77,6	10	125	0,40	36
415	5	92,2	12	150	0,45	36
440	1,67	27	3,8	75	0,22	36
440	2,5	41,1	5,7	110	0,32	36
440	3,33	54,8	7,6	110	0,32	36
440	4,17	68,5	9,5	150	0,45	36
440	5	82,2	11,4	150	0,45	36
460	1,67	25	3,6	75	0,22	36
460	2,5	37,6	5,4	87	0,27	36
460	3,33	50,1	7,2	110	0,32	36
460	4,17	62,7	9	150	0,45	36
460	5	75,2	10,9	150	0,45	36
525	1,67	19,3	3,1	75	0,22	36
525	2,5	28,9	4,8	100	0,30	36
525	3,33	38,5	6,3	125	0,40	36
525	4,17	48,2	7,9	150	0,45	36
550	1,67	17,5	3	75	0,22	36
550	2,5	26,3	4,5	110	0,32	36
550	3,33	35	6	125	0,40	36
550	4,17	43,8	7,6	150	0,45	36
550	5	52,6	9,1	150	0,45	36

Single-phase capacitor KNK5015, 60 Hz

U_n (V)	Q_n (kvar)	C_n (μ F)	I_n (A)	H (mm)	I_n (A)	H (mm)
220	1,67	91,3	7,5	110	0,32	36
220	2,5	137	11,3	150	0,45	36
420	1,67	25	3,9	75	0,22	36
420	3,33	50,1	7,9	110	0,32	36
420	4,17	62,6	9,9	125	0,40	36
420	5	75,2	11,9	150	0,45	36
440	1,67	22,8	3,8	75	0,22	36
440	3,33	45,4	7,5	110	0,32	36
440	4,17	56,9	9,4	125	0,40	36
440	5	68,4	11,3	150	0,45	36
460	1,67	20,9	3,6	75	0,22	36
460	3,33	41,7	7,2	110	0,32	36
460	4,17	52,3	9	110	0,32	36
460	5	62,7	10,8	125	0,40	36

2. Three-phase capacitors in aluminium housing type KNK5065

Figure 4

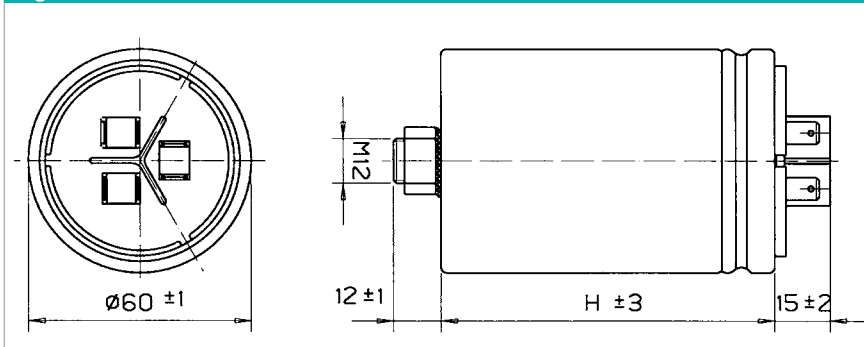

Rated voltage 400 V, 50 Hz

Rated power (kvar)	Rated capacitance (μF)	Rated current (A)	H (mm)	Weight (kg)	Packing unit (pcs)
2,5	3 × 16,6	3,6	145	0,45	36
3	3 × 19,9	4,3	145	0,45	36
4	3 × 26,5	5,8	185	0,55	36
5	3 × 33,2	7,2	185	0,55	36

Rated voltage 440 V, 50 Hz

Rated power (kvar)	Rated capacitance (μF)	Rated current (A)	H (mm)	Weight (kg)	Packing unit (pcs)
2,5	3 × 13,7	3,3	145	0,45	36
3	3 × 16,5	3,9	145	0,45	36
4	3 × 21,9	5,3	185	0,55	36
5	3 × 27,4	6,6	185	0,55	36

Rated voltage 460 V, 50 Hz

Rated power (kvar)	Rated capacitance (μF)	Rated current (A)	H (mm)	Weight (kg)	Packing unit (pcs)
2,5	3 × 12,5	3,1	145	0,45	36
3	3 × 15,0	3,7	145	0,45	36
4	3 × 20,0	5	185	0,55	36
5	3 × 25,1	6,3	185	0,55	36

Rated voltage 525 V, 50 Hz

Rated power (kvar)	Rated capacitance (μF)	Rated current (A)	H (mm)	Weight (kg)	Packing unit (pcs)
2,5	3 × 9,6	2,7	145	0,45	36
3	3 × 11,5	3,3	145	0,45	36
4	3 × 15,4	4,4	185	0,55	36
5	3 × 19,3	5,5	185	0,55	36

3. Three-phase capacitors in aluminium housing type KNK6049

Figure 5

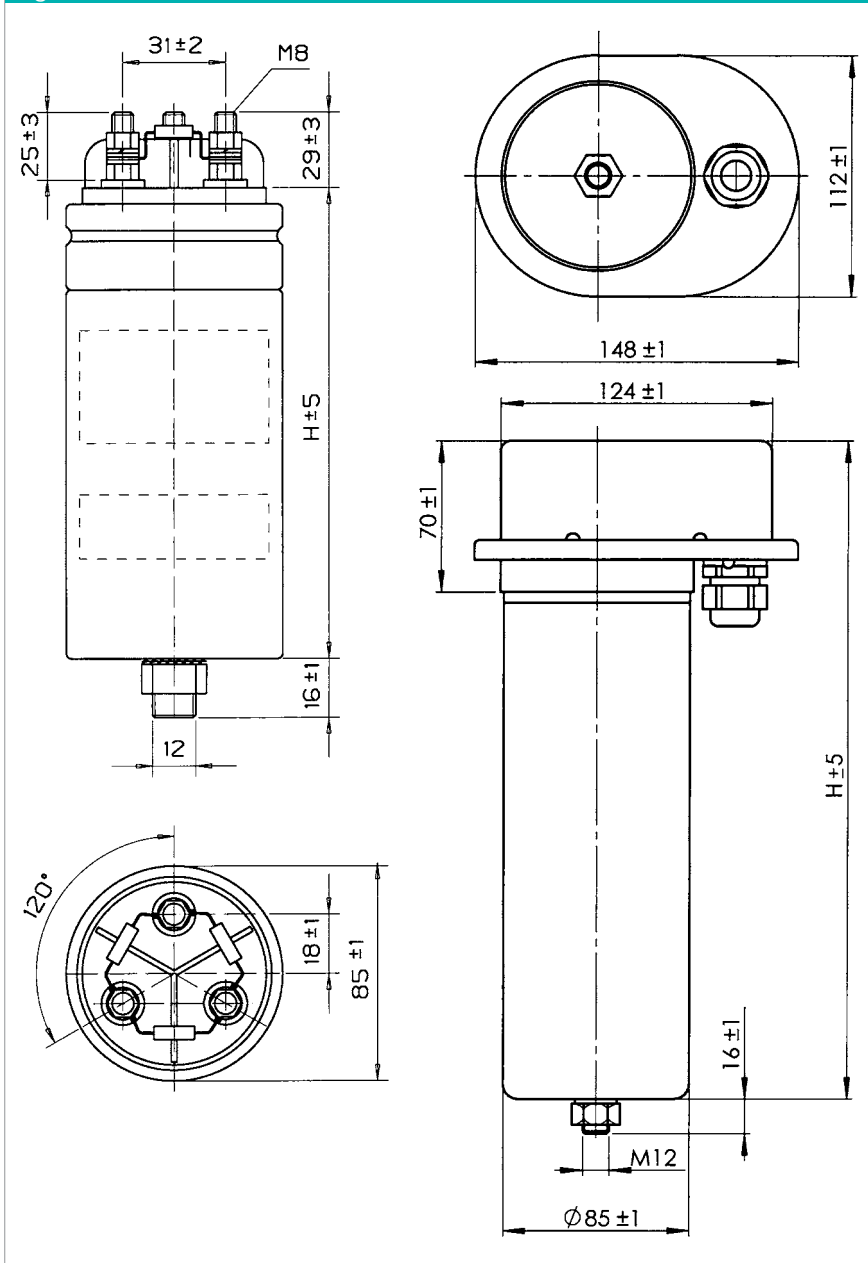

Three-phase capacitors in aluminium cylindrical housing type KNK6049

Rated voltage and rated frequency	Rated power (kvar)	Rated capacitance (μF)	Rated current at 50 Hz (A)	Rated current at 60 Hz (A)	H (mm)	Weight (kg)	Packing unit (pcs)
400 V 50 Hz	10	3 × 66,3	14,4	-	220	1,35	16
	12,5	3 × 83,3	18,0	-	260	1,60	16
	15	3 × 100	21,7	-	260	1,60	16
	20	3 × 133,0	28,9	-	325	1,90	16
	25	3 × 165,8	36,1	-	370	2,20	16
420 V 50 Hz	10	3 × 60,2	12,5	-	220	1,35	16
	12,5	3 × 75,3	15,6	-	260	1,60	16
	15	3 × 90,2	18,8	-	295	1,75	16
	20	3 × 120,4	25,0	-	370	2,20	16
440 V 50 Hz 400 V 60 Hz	10	3 × 54,8	13,1	14,4	220	1,35	16
	12,5	3 × 68,5	16,4	18	260	1,60	16
	15	3 × 82,5	19,7	21,7	295	1,75	16
	20	3 × 109,7	26,2	26,2	370	2,20	16
	25	3 × 137,1	32,8	36,1	370	2,20	16
460 V 50 Hz 420 V 60 Hz	10	3 × 50,2	12,6	13,8	220	1,35	16
	12,5	3 × 62,5	15,7	17,2	260	1,60	16
	15	3 × 75,3	18,8	20,6	295	1,75	16
	20	3 × 100,3	25,1	27,6	325	1,90	16
	25	3 × 125,4	31,3	34,4	370	2,20	16
480 V 50 Hz 440 V 60 Hz	10	3 × 46,1	12	13,1	220	1,35	16
	12,5	3 × 57,7	15,1	16,4	260	1,60	16
	15	3 × 69,1	18,1	19,7	295	1,75	16
	20	3 × 92,1	24,1	26,2	370	2,20	16
500 V 50 Hz 460 V 60 Hz	10	3 × 42,5	11,6	12,6	260	1,60	16
	12,5	3 × 53,1	14,4	15,7	295	1,75	16
	15	3 × 63,7	17,3	18,8	325	1,90	16
	20	3 × 84,9	23,1	25,1	370	2,20	16
525 V 50 Hz 480 V 60 Hz	10	3 × 38,5	11	12	260	1,60	16
	12,5	3 × 48,1	13,8	15,1	295	1,75	16
	15	3 × 57,7	16,5	18,1	325	1,90	16
	20	3 × 77,0	22	24,1	370	2,20	16
	25	3 × 96,2	27,5	30,1	370	2,20	16

4. Three-phase power factor correction capacitors type KNK9053

Figure 6

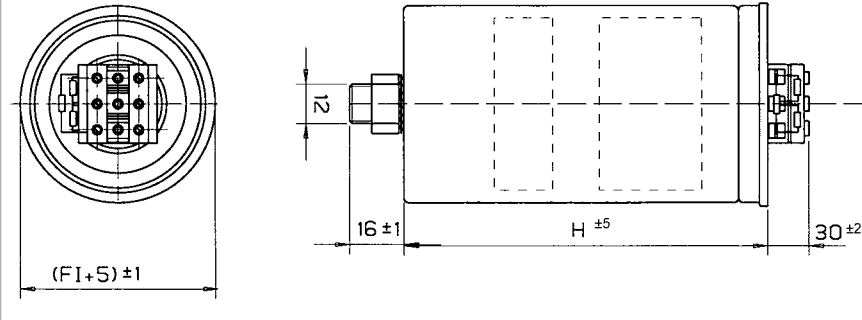

TECHNICAL DATA

Rated voltage U_n :	see table
Rated frequency:	50 Hz or 60 Hz
Capacitance tolerance:	- 5 % to + 15 %
Losses: - dielectric - total	< 0,2 W/kvar < 0,5 W/kvar
Protection degree:	IP 20
Discharge time :	≤ 3 min. to 75 V or less by discharge resistors
Standards:	IEC Publ. 60831 - 1/2
Safety:	self-healing, overpressure disconnecter
Dielectric:	metallized polypropylene film; sealed with plant oil, PCB-free
Permitted ambient temperature:	- 25 °C to + 55 °C, other on request
Permitted storage temperature:	- 40 °C to + 70 °C
Permitted overload:	1,1 × U_n (8 h per day) 1,3 × I_n (rated current)
In-rush current:	130 × I_n max.
Test conditions:	between layers 2,15 × U_n , AC, 2 s layers-housing 3,6 kV, AC, 2 s
Max. weight per kvar:	cylindrical housing: 0,1 kg

Three-phase capacitors in aluminium cylindrical housing type KNK9053 ($f_n = 50 \text{ Hz}$)

C_n (μF)	Q_n (kvar)	I_n (A)	Q_n (kvar)	I_n (A)	Q_n (kvar)	I_n (A)	H (mm)	FI (mm)	Weight (kg)	Packing unit (pcs)
$U_n = 525 \text{ V}$		$U_n = 525 \text{ V}$		$U_n = 460 \text{ V}$		$U_n = 440 \text{ V}$				
3x38,5	10	11	7,7	9,7	7,0	9,2	205	90	1,35	16
3x48,2	12,5	13,8	9,6	12	8,8	11,5	240	90	1,60	16
3x57,8	15	16,5	11,5	14,4	10,5	13,8	240	90	1,60	16
3x77,0	20	22	15,3	19,2	14,0	18,4	205	116	1,90	9
3x96,3	25	27,5	19,2	24,1	17,6	23,1	240	116	2,20	9
$U_n = 460 \text{ V}$		$U_n = 460 \text{ V}$		$U_n = 440 \text{ V}$		$U_n = 420 \text{ V}$				
3x50,2	10	12,6	9,2	12,1	8,3	11,4	205	90	1,35	16
3x62,7	12,5	15,7	11,4	15	10,4	14,3	205	90	1,35	16
3x75,2	15	18,8	13,7	18	12,5	17,2	240	90	1,60	16
3x100,3	20	25,1	18,3	24	16,7	23	205	116	1,90	9
3x125,4	25	31,3	22,9	30	20,8	28,6	240	116	2,20	9
$U_n = 440 \text{ V}$		$U_n = 440 \text{ V}$		$U_n = 420 \text{ V}$		$U_n = 400 \text{ V}$				
3x54,9	10	13,1	9,1	12,5	8,3	12	205	90	1,35	16
3x68,6	12,5	16,4	11,5	15,8	10,4	15	205	90	1,35	16
3x82,3	15	19,7	13,7	18,8	12,4	17,9	240	90	1,60	16
3x110,0	20	26,2	18,3	25,2	16,6	24	205	116	1,90	9
3x137,1	25	32,8	22,8	31,3	20,7	29,9	240	116	2,20	9
$U_n = 420 \text{ V}$		$U_n = 420 \text{ V}$		$U_n = 400 \text{ V}$		$U_n = 380 \text{ V}$				
3x60,2	10	13,7	9,1	13,1	8,2	12,5	205	90	1,35	16
3x75,2	12,5	17,2	11,3	16,3	10,2	15,5	240	90	1,60	16
3x90,3	15	20,6	13,6	19,6	12,3	18,7	240	90	1,60	16
3x120,3	20	27,5	18,1	26,1	16,4	24,9	205	116	1,90	9
3x150,4	25	34,4	22,7	31,2	20,5	28,2	240	116	2,20	9
$U_n = 400 \text{ V}$		$U_n = 400 \text{ V}$		$U_n = 380 \text{ V}$						
3x66,3	10	14,4	9,0	13,7			205	90	1,35	16
3x83,3	12,5	18	11,3	17,2			205	90	1,35	16
3x100	15	21,7	13,6	20,7			240	90	1,60	16
3x133	20	28,9	18,1	27,5			205	116	1,90	9
3x165,8	25	36,1	22,6	34,3			240	116	2,20	9

Three-phase capacitors in aluminium cylindrical housing type KNK9053 ($f_n = 60\text{Hz}$)

C_n (μF)	Q_n (kvar)	I_n (A)	Q_n (kvar)	I_n (A)	Q_n (kvar)	I_n (A)	H (mm)	FI (mm)	Weight (kg)	Packing unit (pcs)
$U_n = 525\text{ V}$		$U_n = 460\text{ V}$		$U_n = 440\text{ V}$						
3x32,1	10	11	7,7	9,7	7,0	9,2	205	90	1,35	16
3x40,1	12,5	13,8	9,6	12	8,8	11,5	205	90	1,35	16
3x48,1	15	16,5	11,5	14,4	10,5	13,8	240	90	1,60	16
3x64,2	20	22	15,3	19,2	14,0	18,4	205	116	1,90	9
3x80,2	25	27,5	19,2	24,1	17,6	23,1	240	116	2,20	9
$U_n = 460\text{ V}$		$U_n = 440\text{ V}$		$U_n = 420\text{ V}$						
3x41,8	10	12,6	9,2	12,1	8,3	11,4	160	90	1,05	16
3x52,2	12,5	15,7	11,4	15	10,4	14,3	205	90	1,35	16
3x62,7	15	18,8	13,7	18	12,5	17,2	205	90	1,35	16
3x83,6	20	25,1	18,3	24	16,7	23	240	90	1,60	16
3x104,5	25	31,3	22,9	30	20,8	28,6	205	116	1,90	9
$U_n = 440\text{ V}$		$U_n = 420\text{ V}$		$U_n = 400\text{ V}$						
3x45,7	10	13,1	9,1	12,5	8,3	12	160	90	1,05	16
3x57,1	12,5	16,4	11,5	15,8	10,4	15	205	90	1,35	16
3x68,5	15	19,7	13,7	18,8	12,4	17,9	205	90	1,35	16
3x91,3	20	26,2	18,3	25,2	16,6	24	240	90	1,60	16
3x114,2	25	32,8	22,8	31,3	20,7	29,9	205	116	1,90	9
$U_n = 420\text{ V}$		$U_n = 400\text{ V}$		$U_n = 380\text{ V}$						
3x50,1	10	13,7	9,1	13,1	8,2	12,5	205	90	1,35	16
3x62,6	12,5	17,2	11,3	16,3	10,2	15,5	205	90	1,35	16
3x75,2	15	20,6	13,6	19,6	12,3	18,7	240	90	1,60	16
3x100,2	20	27,5	18,1	26,1	16,4	24,9	205	116	1,90	9
3x125,3	25	34,4	22,6	32,6	20,4	31,0	240	116	2,20	9
$U_n = 400\text{ V}$		$U_n = 380\text{ V}$								
3x55,3	10	14,4	9,0	13,7			160	90	1,05	16
3x69,7	12,5	18	11,3	17,2			205	90	1,35	16
3x82,9	15	21,7	13,6	20,7			205	90	1,35	16
3x110,5	20	28,9	18,1	27,5			240	90	1,60	16
3x138,2	25	36,1	22,6	34,3			205	116	1,90	9

5. Three-phase capacitors KNK9103 and KNK9143

Figure 7

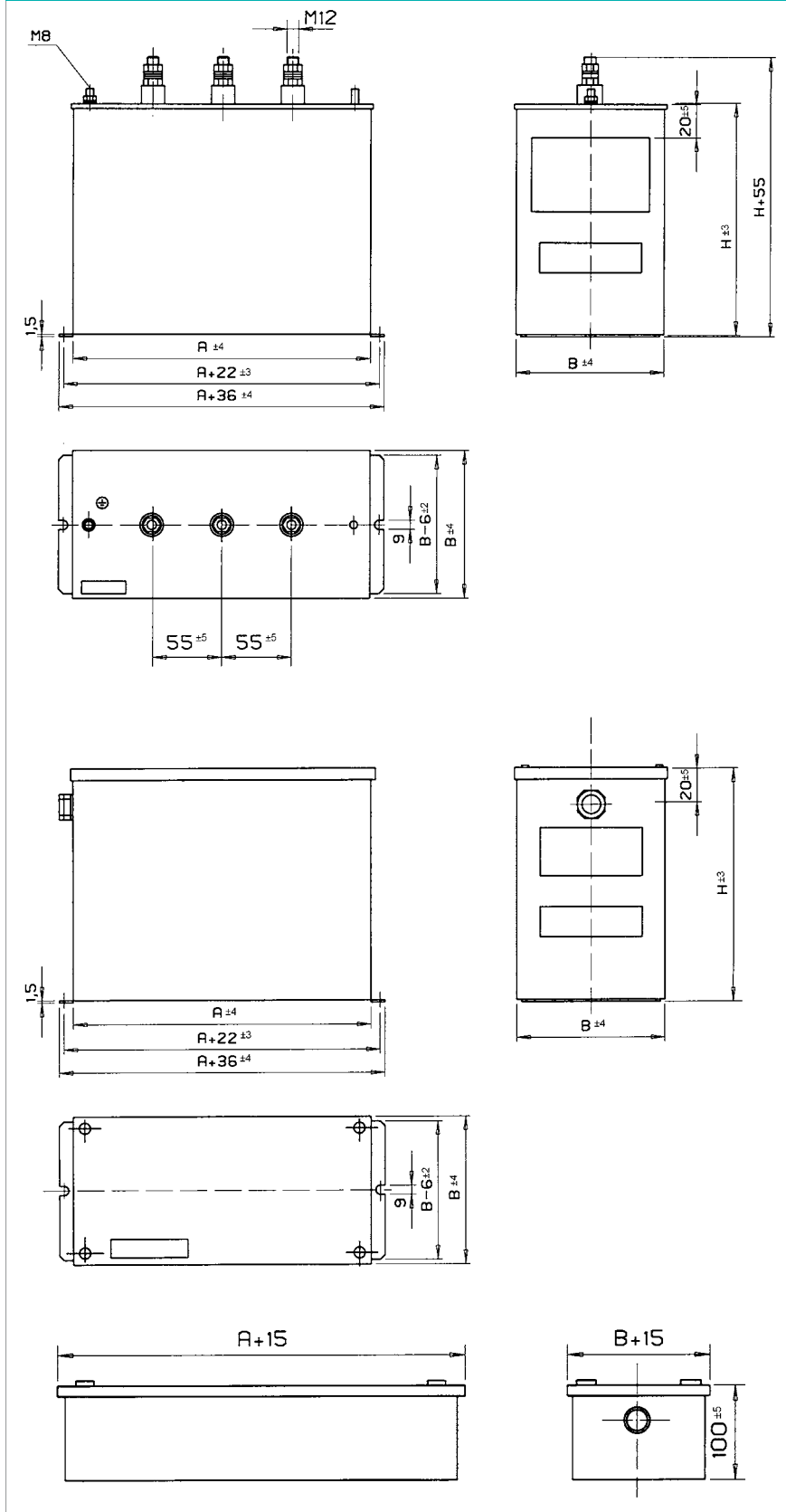

Three-phase capacitors KNK9103 and KNK9143, 50 Hz

U_n (V)	Q_n (kvar)	C_n (μ F)	I_n (A)	A (mm)	A' (mm)	B (mm)	D	Weight KNK9103 (kg)	Weight KNK9143 (kg)
230	5	3 × 100,3	12,5	190	190	70	M 8	3,65	6,40
230	10	3 × 200,7	25,1	380	190	70	M 8	5,65	7,30
230	12,5	3 × 250,7	31,1	380	190	70	M 8	5,95	7,80
230	15	3 × 301,0	37,6	380	380	140	M 12	8,30	12,40
230	20	3 × 401,2	50,2	380	380	140	M 12	9,65	13,20
230	25	3 × 501,5	62,7	380	380	140	M 12	10,25	13,80
400	5	3 × 33,2	7,2	190	190	70	M 8	2,95	6,00
400	7,5	3 × 49,7	10,8	190	190	70	M 8	3,05	6,10
400	10	3 × 66,3	14,4	190	190	70	M 8	3,25	6,25
400	12,5	3 × 82,9	18	190	190	70	M 8	3,30	6,30
400	15	3 × 99,5	21,7	190	190	70	M 8	3,65	6,45
400	20	3 × 132,6	28,9	380	190	70	M 8	5,65	7,30
400	25	3 × 165,8	36,1	380	190	70	M 8	5,95	7,80
400	30	3 × 198,9	43,3	380	190	70	M 8	6,25	8,10
400	40	3 × 265,3	57,7	380	380	140	M 12	8,30	12,20
400	50	3 × 331,6	72,2	380	380	140	M 12	9,65	13,20
400	60	3 × 397,9	86,6	380	380	140	M 12	10,25	13,80
415	5	3 × 30,8	7	190	190	70	M 8	2,95	6,10
415	7,5	3 × 46,2	10,4	190	190	70	M 8	3,05	6,25
415	10	3 × 61,6	13,9	190	190	70	M 8	3,25	6,30
415	12,5	3 × 77,0	17,4	190	190	70	M 8	3,30	6,45
415	15	3 × 92,4	20,9	380	190	70	M 8	3,65	7,30
415	20	3 × 123,2	27,8	380	190	70	M 8	5,65	7,80
415	25	3 × 154,0	34,8	380	190	70	M 8	5,95	8,10
415	30	3 × 184,0	41,7	380	190	70	M 8	6,25	8,40
415	40	3 × 246,4	55,7	380	380	140	M 12	8,30	12,20
415	50	3 × 308,0	69,6	380	380	140	M 12	9,65	13,20
440	5	3 × 27,4	6,5	190	190	70	M 8	2,95	6,00
440	7,5	3 × 41,1	9,8	190	190	70	M 8	3,05	6,10
440	10	3 × 54,8	13,1	190	190	70	M 8	3,25	6,25
440	12,5	3 × 68,5	16,4	190	190	70	M 8	3,30	6,30
440	15	3 × 82,2	19,7	190	190	70	M 8	3,65	6,45
440	20	3 × 109,6	26,3	380	190	70	M 8	3,65	7,30
440	25	3 × 137,0	32,8	380	190	70	M 8	5,95	7,80
440	30	3 × 164,4	39,4	380	190	70	M 8	6,25	8,10
440	40	3 × 219,2	52,6	380	380	140	M 12	8,30	12,20
440	50	3 × 272,0	65,6	380	380	140	M 12	9,65	13,20
440	60	3 × 328,8	78,8	380	380	140	M 12	10,25	13,80

Three-phase capacitors KNK9103 and KNK9143, 50 Hz

U_n (50 Hz) (V)	Q_n (kvar)	C_n (μ F)	I_n (A)	A (mm)	A' (mm)	B (mm)	D	Weight KNK9103 (kg)	Weight KNK9143 (kg)
460	5	3 × 25,0	6,2	190	190	70	M 8	2,95	6,00
460	7.5	3 × 37,6	9,4	190	190	70	M 8	3,05	6,10
460	10	3 × 50,1	12,5	190	190	70	M 8	3,25	6,25
460	12.5	3 × 62,6	15,6	190	190	70	M 8	3,30	6,30
460	15	3 × 75,2	18,8	190	190	70	M 8	3,65	6,45
460	20	3 × 100,2	25,1	380	190	70	M 8	5,65	7,30
460	25	3 × 125,3	31,3	380	190	70	M 8	5,95	7,80
460	30	3 × 150,3	37,6	380	190	70	M 8	6,25	8,10
460	40	3 × 200,5	50,2	380	380	140	M 12	8,30	12,20
460	50	3 × 250,6	62,7	380	380	140	M 12	9,65	13,20
460	60	3 × 300,6	75,3	380	380	140	M 12	10,25	13,80
525	5	3 × 19,3	5,5	190	190	70	M 8	2,95	6,10
525	7.5	3 × 28,9	8,2	190	190	70	M 8	3,05	6,25
525	10	3 × 39,0	11	190	190	70	M 8	3,25	6,30
525	12.5	3 × 48,1	13,8	190	190	70	M 8	3,30	6,45
525	15	3 × 57,7	16,5	190	190	70	M 8	3,65	7,30
525	20	3 × 77,0	22	380	190	70	M 8	5,65	7,80
525	25	3 × 92,2	27,5	380	190	70	M 8	5,95	8,10
525	30	3 × 115,5	33	380	380	140	M 12	6,25	12,20
525	40	3 × 154,0	44	380	380	140	M 12	8,30	13,20
525	50	3 × 192,5	55	380	380	140	M 12	9,65	13,80
550	5	3 × 19,3	5,2	190	190	70	M 8	2,95	6,00
550	7.5	3 × 26,3	7,8	190	190	70	M 8	3,05	6,10
550	10	3 × 35,0	10,5	190	190	70	M 8	3,25	6,25
550	12.5	3 × 43,7	13,1	190	190	70	M 8	3,30	6,30
550	15	3 × 52,5	15,7	190	190	70	M 8	3,65	6,45
550	20	3 × 70,1	20,9	380	190	70	M 8	5,65	7,30
550	25	3 × 87,5	26,2	380	190	70	M 8	5,95	7,80
550	30	3 × 105,0	31,5	380	190	70	M 8	6,25	8,10
550	40	3 × 140,2	41,9	380	380	140	M 12	8,30	12,20
550	50	3 × 175,0	52,5	380	380	140	M 12	9,65	13,2
550	60	3 × 210,3	63	380	380	140	M 12	10,25	13,8

Three-phase capacitors KNK9103 and KNK9143, 60 Hz

U_n (50 Hz) (V)	Q_n (kvar)	C_n (μ F)	I_n (A)	A (mm)	A' (mm)	B (mm)	D	Weight KNK9103 (kg)	Weight KNK9143 (kg)
220	5	3 × 91,3	13,13	190	190	70	M 8	3,65	6,40
220	10	3 × 182,6	26,27	380	190	70	M 8	5,95	7,30
220	15	3 × 273,9	39,41	380	190	70	M 8	6,25	7,75
220	20	3 × 365,2	52,54	380	380	140	M 12	8,30	12,10
220	25	3 × 456,5	65,68	380	380	140	M 12	9,65	13,10
220	30	3 × 547,8	78,82	380	380	140	M 12	10,25	13,70
420	5	3 × 25,0	6,88	190	190	70	M 8	2,95	6,10
420	10	3 × 50,1	13,7	190	190	70	M 8	3,25	6,20
420	15	3 × 75,2	20,64	190	190	70	M 8	3,65	6,40
420	20	3 × 100,2	27,5	380	190	70	M 8	5,65	7,25
420	25	3 × 125,3	34,4	380	190	70	M 8	5,95	7,70
420	30	3 × 150,4	41,28	380	190	70	M 8	6,25	8,00
420	50	3 × 250,6	68,8	380	380	140	M 12	9,65	13,10
420	60	3 × 300,8	82,57	380	380	140	M 12	10,25	13,70
440	5	3 × 22,8	6,5	190	190	70	M 8	2,95	6,10
440	10	3 × 45,7	13,1	190	190	70	M 8	3,25	6,20
440	15	3 × 68,5	19,6	190	190	70	M 8	3,65	6,40
440	20	3 × 91,3	26	380	190	70	M 8	5,65	7,25
440	25	3 × 114,2	32,8	380	190	70	M 8	5,95	7,70
440	30	3 × 137,0	39,4	380	190	70	M 8	6,25	8,00
440	50	3 × 228,4	65,6	380	380	140	M 12	9,65	13,10
440	60	3 × 274,0	78,7	380	380	140	M 12	10,25	13,70
460	5	3 × 20,8	6,3	190	190	70	M 8	2,95	6,10
460	10	3 × 41,6	12,6	190	190	70	M 8	3,25	6,20
460	15	3 × 62,2	18,9	190	190	70	M 8	3,65	6,40
460	20	3 × 83,2	25,2	380	190	70	M 8	5,65	7,25
460	25	3 × 104,3	31,5	380	190	70	M 8	5,95	7,70
460	30	3 × 125,2	37,8	380	190	70	M 8	6,25	8,00
460	50	3 × 208,6	63	380	380	140	M 12	9,65	13,10
460	60	3 × 250,7	75,3	380	380	140	M 12	10,25	13,70

6. Single-phase capacitors KNK9101 and KNK9141

Figure 8

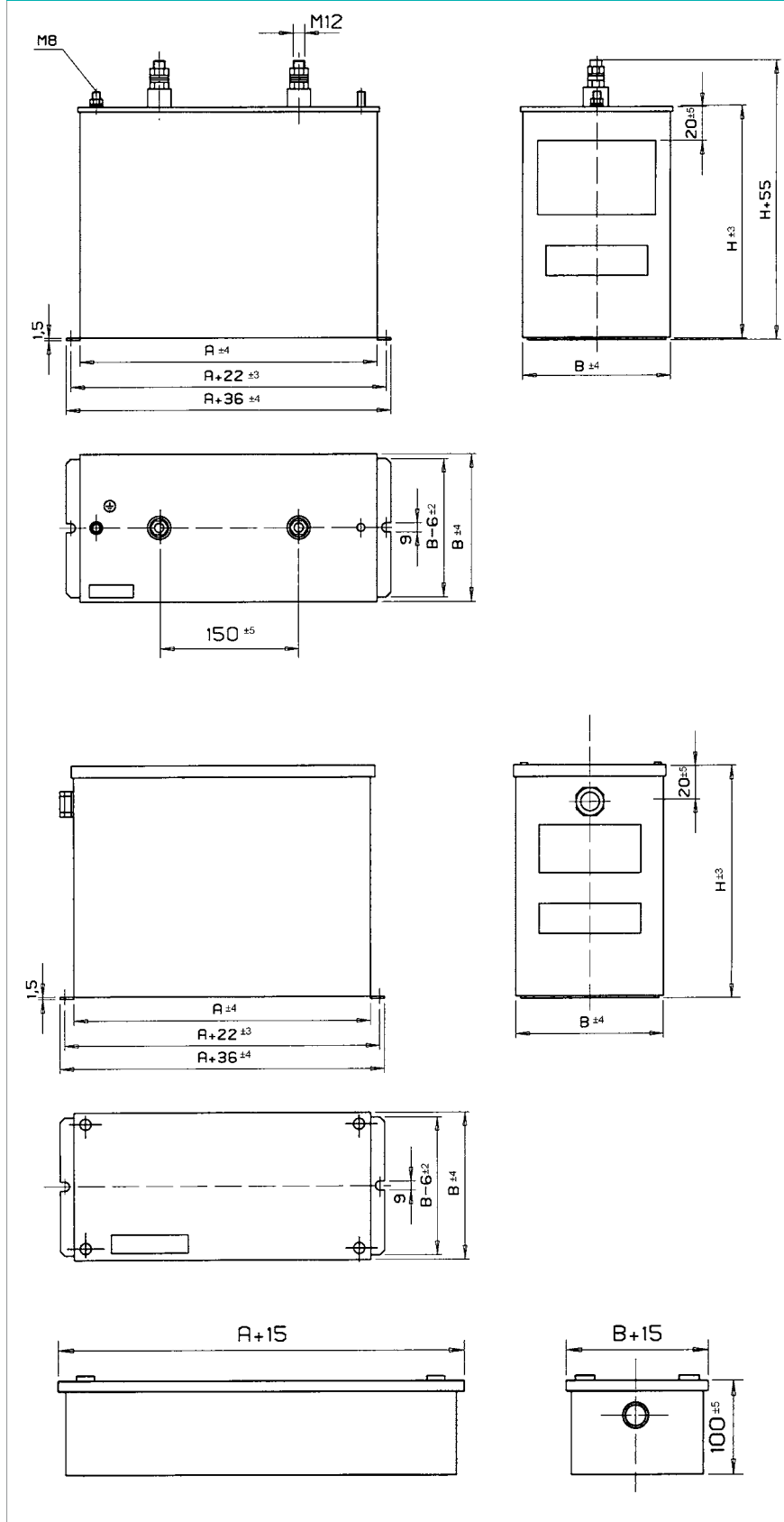

Single-phase capacitors KNK9101 and KNK9141, 50 Hz

U_n (V)	Q_n (kvar)	C_n (μ F)	I_n (A)	A (mm)	A' (mm)	B (mm)	D	Weight KNK9101 (kg)	Weight KNK9141 (kg)
230	5	300,9	21,7	190	190	70	M 8	3,60	6,40
230	7,5	450,6	32,6	380	190	70	M 8	5,30	7,25
230	10	602,1	43,4	380	190	70	M 8	5,60	7,70
230	12,5	752,1	54,3	380	190	70	M 8	5,90	8,00
230	15	903	65,2	380	380	140	M 12	8,25	12,10
230	20	1203,6	86,9	380	380	140	M 12	9,60	13,10
230	25	1504,4	108,6	380	380	140	M 12	10,20	13,70
400	5	99,5	12,5	190	190	70	M 8	2,90	5,90
400	7,5	149,1	18,7	190	190	70	M 8	3,00	6,00
400	10	198,8	25	190	190	70	M 8	3,20	6,10
400	12,5	248,5	31,2	190	190	70	M 8	3,25	6,20
400	15	298,2	37,5	190	190	70	M 8	3,60	6,40
400	20	397,6	50	380	190	70	M 8	5,60	7,25
400	25	497	62,5	380	190	70	M 8	5,90	7,70
400	30	596,4	75	380	190	70	M 8	6,25	8,00
400	40	795,2	100	380	380	140	M 12	8,25	12,10
400	50	994	125	380	380	140	M 12	9,60	13,10
550	5	52,5	9,1	190	190	70	M 8	2,90	5,90
550	7,5	78,7	13,6	190	190	70	M 8	3,00	6,00
550	10	105	18,1	190	190	70	M 8	3,20	6,10
550	12,5	131,2	22,7	190	190	70	M 8	3,25	6,20
550	15	157,5	27,2	190	190	70	M 8	3,60	6,40
550	20	210	36,3	380	190	70	M 8	5,60	7,25
550	25	262,5	45,4	380	190	70	M 8	5,90	7,70
550	30	315	54,5	380	190	70	M 8	6,25	8,00
550	40	420	72,7	380	380	140	M 12	8,25	12,10
550	50	525	90,9	380	380	140	M 12	9,60	13,10
550	60	630	109,1	380	380	140	M 12	10,20	13,70

Basic of power factor correction

1. Capacitor power ratings for individual compensation of motors (reference values)

Rated power of motor (kW)	Power ratings of capacitor in (kvar) with respect to motor power, speed of rotation and load									
	3000 rev/min		1500 rev/min		1000 rev/min		750 rev/min		500 rev/min	
	No load	Full load	No load	Full load	No load	Full load	No load	Full load	No load	Full load
5,5	2,2	2,9	2,4	3,3	2,7	3,6	3,2	4,3	4	5,2
7,5	3,4	4,4	3,6	4,8	4,1	5,4	4,6	6,1	5,5	7,2
11	5	6,5	5,5	7,2	6	8	7	9	7,5	10
15	6,5	8,5	7	9,5	8	10	9	12	10	13
18,5	8	11	9	12	10	13	11	15	12	16
22	10	12,5	11	13,5	12	15	13	16	15	19
30	14	18	15	20	17	22	22	25	22	28
37	18	24	20	27	22	30	26	34	29	39
45	19	28	21	31	24	34	28	38	31	43
55	22	34	25	37	28	41	32	46	36	52
75	28	45	32	49	37	54	41	60	45	68
90	34	54	39	59	44	65	49	72	54	83
110	40	64	46	70	52	76	58	85	63	98
132	45	72	53	80	60	87	67	97	75	110
160	54	86	64	96	72	103	81	116	91	132
200	66	103	77	115	87	125	97	140	110	160
250	75	115	85	125	95	137	105	150	120	175

The required capacitor power is calculated with the formula:

$$Q_n = 0,9 \cdot U_n \cdot I_{mag} \cdot \sqrt{3}$$

where:

Q_n - is rated capacitor power (kvar)

U_n - is rated motor voltage (kV)

I_{mag} - is motor magnetising current (A)

Instructions for the selection of capacitor power, cross-section of supply cables, fuse ratings and bases are given for determining the individual compensation of reactive power of motors and transformers.

The following tables show the reference values needed in dependence of their power.

Recommended cross-section of supply cables, fuse ratings and bases are also given in dependence of capacitor phase currents.

2. Approximate capacitor power for the compensation of reactive power of transformers

Rated power of transformer (kW)	Power ratings of capacitor In (kvar) with respect to primary voltage and load					
	5-10 kV		15-20 kV		25-30 kV	
	No load	Full load	No load	Full load	No load	Full load
5	0,75	1	0,8	1,1	1	1,3
10	1,2	1,7	1,5	2	1,7	2,2
20	2	3	2,5	3,5	3	4
25	2,5	3,5	3	4	4	5
75	5	8	6	9	7	11
100	6	10	8	11	10	13
160	10	12	12	15	15	18
200	11	17	14	19	18	22
250	15	20	18	22	20	25
315	18	25	20	28	24	32
400	20	30	22	36	28	40
500	22	40	25	45	30	50
630	28	46	32	52	40	62
1000	45	80	50	85	55	95
1250	50	85	55	90	60	100
1600	70	100	60	110	70	120
2000	80	160	85	170	90	180
5000	150	180	170	200	200	250

- For welding transformers, capacitors with approximately 50 % of transformer rated power are used for compensating reactive power.

- For rectifier welding transformers, capacitors with approximately 10 % of transformer power are used for compensating reactive power.

- For individual compensation of fluorescent, Na and Hg lamps, special capacitors type KNF (see brochure) are recommended. Capacitors KNK or automatic banks, made up of these capacitors, are recommended for group compensation.

Rated cap. current Δ delta-connection (A)	Cross-section of Cu multi-wire cable (mm ²)	Slow fuse and base (A)
to 6	1.5	10
6-10	2.5	16
10-12	2.5	20
12-15	4	25
15-20	6	35
20-30	10	50

Rated cap. current Δ delta-connection (A)	Cross-section of Cu multi-wire cable (mm ²)	Slow fuse and base (A)
30-40	16	63
40-47	25	80
47-65	35	100
65-80	50	125
80-102	70	160

(VDE 0660 - 5/67; VDE 0110, IEC 439, IEC 593, National Electrical Code and others).

General on power factor correction

Causes

Electrical energy, in various types of consumers, changes into different forms such as heat, mechanical action, and other. Alternative current installations such as asynchronous motors, transformers, AC commutator machines, furnaces etc., need a current I consisting of active and reactive components. The active current I_d is in phase with the voltage and aids in producing active power. The reactive components of current I_j electrically lag in phase for $90^\circ (\pi/2)$ behind the voltage and serve for exciting the magnetic flux necessary for inducing voltage U_i there by providing electrical and indirectly, mechanical power.

3. Cross-section of supply cables and fuse ratings with bases for capacitor protection

Capacitor units must be protected from short -duration overloading and short circuits by fuses with values between $1,43$ and $1,8 \times I_n$ of the capacitor.

Due to short-duration in-rush currents, fuses must have corresponding melting characteristics (slow fuse).

Connection cables are designed to withstand continuous 1,5 times rated current.

- Cross-sections are given for overhead cables and ambient temperature of 30°C . For other temperatures ratings and other materials a correction factor should be considered.

- For application and mounting purposes, national standards governing mounting and safety conditions for low voltage equipment must be observed

Figure 9

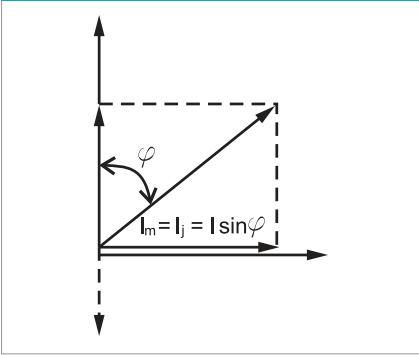

This can be illustrated by a substitute circuit with ohmic and inductive resistance connected in parallel. The diagram illustrates the apparent current I which is the geometric sum of the active I_d and reactive current I_j . This current lags behind the applied voltage for an angle φ .

The greater the number of consumers connected to the network, the greater the phase shift which however, is unwanted since it conditions the following expressions for the working, the reactive, and the apparent power (e.g. in three-phase systems):

$$P = \sqrt{3} \cdot U \cdot I_d$$

$$= \sqrt{3} \cdot U \cdot I \cdot \cos\varphi \cdot 10^{-3} \text{ (kW)}$$

$$Q = \sqrt{3} \cdot U \cdot I_j$$

$$= \sqrt{3} \cdot U \cdot I \cdot \sin\varphi \cdot 10^{-3} \text{ (kvar)}$$

$$S = \sqrt{3} \cdot U \cdot I = \sqrt{3} \cdot U \cdot I \cdot 10^{-3} \text{ (kVA)}$$

$$\cos\varphi = \frac{I_d}{I} = \frac{P}{S} \dots \text{is the power factor}$$

The diagram with parallel connection of ohmic and inductive resistance is not sufficient when dealing with the above mentioned equipment, since the appearance of stray magnetic flux (which is wanted only in certain specific cases) cannot be prevented in practice.

Due to flux, the AC equipment demonstrates series inductive resistance at the same time, which provides a substitute circuit and the diagram in figure 9.

Figure 10

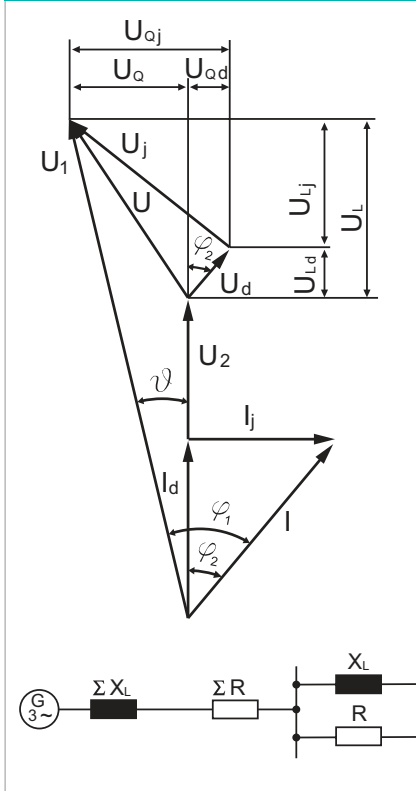

In equipment with parallel resistances the reactive power is the product of the magnetizing current I_j and the applied voltage, whereas in equipment with resistances connected in series it is the product of the apparent current I and inductive voltage drop U_j .

Both types of equipment require reactive power and are the cause of electrical power factor reduction in the network.

The results of such a condition

1. Electric power stations supplying large numbers of inductive and ohmic consumers must supply the necessary apparent power. Power lines must be designed to carry higher powers than needed for active power. For a certain constant active power the apparent power increases with the increase of reactive power according to the formula:

$$S = \frac{P}{\cos\varphi}$$

Ideal for transmission would be when $\cos\varphi = 1$, since the power station would then supply pure

active power.

2. Electric power transmission brings about loss, which increases as a function of the length of a transmission line and of the power factor.

To explain this, let us take that a consumer operates with a $\cos\varphi = 0,7$ ($I_d = I_j$).

Apparent power is:

$$I = \sqrt{I_d^2 + I_j^2} = I_d \sqrt{2}$$

Joule losses increase two times at transmission of such power with regard to power transmission at $\cos\varphi = 1$:

$$P_{izg} = I^2 \cdot R = 2 \cdot I_d^2 \cdot R$$

3. With long transmission lines voltage drop increases remarkably i.e. the inductive part more than the ohmic. Increasing the conductor cross-section therefore, does not solve the problem. The only solution is to improve $\cos\varphi$.

How to improve such unfavourable conditions?

The reactive power needed can be produced by employing suitable capacitors connected in parallel relieving, thereby, production and transmission of electrical power.

The functioning of capacitors producing electrical power, can be explained as follows.

It is known that a magnetic field in non-corrected networks is excited and made to disappear by a pulsating magnetizing current. A suitable capacitor is connected in parallel to a consumer of reactive power, which at the disappearance of the electromagnetic field, collects the released energy and uses this for exciting its own electro-static field (dielectric charging).

Immediately after, in the rhythm of the alternating current, the capacitor at the disappearance of the electrostatic field provides the released power for exciting the electromagnetic field with hardly any loss (dielectric discharge).

This released energy oscillates with double network frequency between the power station and the electrical energy consumer. In this way, the capacitor covers the needs for reactive power of the inductive in parallel connected consumers.

The capacitor therefore, relieves production and transmission of reactive power by its correction. The diagram illustrates the ideal functioning of correction.

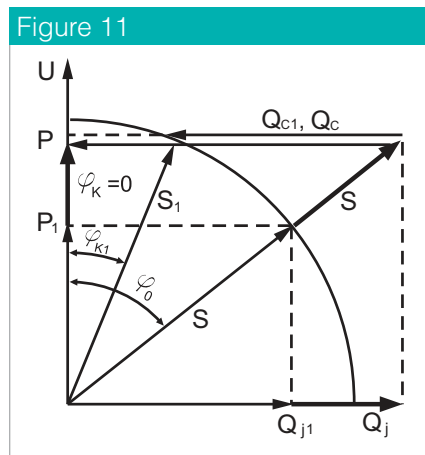

Advantages of power factor correction

1. By incorporating a power factor system at the consumers end the power station is relieved from supplying reactive power and can therefore, use its full capacity for producing useful active energy.

2. Transmission lines are freed of reactive power, Joule losses largely decrease as $X_L \rightarrow 0$ and $\cos\phi$ approaches the ideal value 1. This relief in the existing plant enables connection of new consumers.

3. Voltage drop at the end of transmission lines largely decreases:

$$U = I \cdot X \cdot \sin\phi + I \cdot R \cdot \sin\phi$$

$$U = I_j \cdot X + I_d \cdot R$$

$\sin\phi \rightarrow 0$ therefore:

$$U = I_d \cdot R$$

4. Rolling-mills and electrochemical plants are large consumers of reactive power while at the same time being the originators of higher harmonics. The following dual effect can be obtained by proper combination of capacitors and chokes:

- correction of internal plant network and

- removal of higher harmonics from internal plant network.

5. Reactive power is produced on the spot (consumer centre) by a capacitor bank, therefore, eliminating payment of excessive reactive power consumption. This in turn increases factor net profit and releases financial funds for other usage.

Higher harmonics present in networks are caused by over saturated transformers, especially rectifiers. Factories using such equipment are at the same time the main originators of higher harmonics and the largest consumers of reactive power, initiating therefore the need for correction.

The problem of overloading of capacitors, or even the appearance of resonance arising with correction, can be solved by adding, in series with the capacitors, a special choke tuned to the harmful higher harmonics. The use of low-loss chokes adds to the plant costs, but provides the following two important advantages:

a) Impedance traps relieve the supply networks of higher harmonics. Problems arising from the controlling of rectifier equipment are eliminated especially at parallel operation.

Above all, conditions causing resonance, which in turn cause overloading of capacitor banks, are eliminated.

b) Capacitors in an impedance trap correct the reactive power of the fundamental wave and reduce electric power expenses.

Methods of power factor correction

Three types should be distinguished:

- individual correction
- group correction and
- central correction

Individual correction

This is especially practicable where larger motors are operated continuously throughout the day such as: pumps, compressors etc. Power -factor correction is possible, without the need of automatic control, up to as high as $\cos\phi_k = 0,95$.

Advantages:

- reactive power is corrected at its origin so that the supply cables are not loaded unnecessarily
- no additional switches and fuses are required since both the electric motor and the capacitor are actuated by a common switch.

The power of a capacitor connected in parallel to the electric motor is calculated by the formula:

$$Q_C = \sqrt{3} \cdot 0,9 \cdot I_0 \cdot U_n \cdot 10^{-3} \text{ (kvar)}$$

or approximately by using the diagram in figure 12.

Attention has to be paid to the following:

1. Motors started with star delta switches must not be directly connected since the switch-over action momentarily switches off the capacitor. Immediate connection of the capacitor is not permitted.

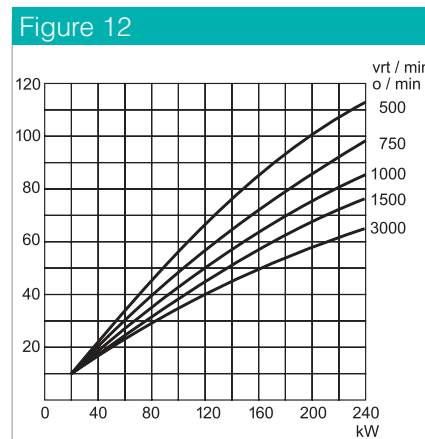

2. With over current or thermal motor protection, current reduction (correction) must be considered.

3. With engines having high torque, care must be taken to prevent over-excitation.

Group correction

A single capacitor bank or power correction equipment can be employed for a large group of small inductive consumers of electric power. The method is especially applicable for groups of small motors.

Usually consumption of reactive power of such a group is extremely variable, therefore, the bank is divided into several stages. In order to rate such stages properly, a daily operating diagram should be drawn up.

Central correction

A group correction system for a complete plant is connected directly to the main busbars. Use is made of automatic control in order to gain a high $\cos\varphi \geq 0,95$ and to reduce the number of staff.

Best results are obtained by combining all three methods of power factor correction, and adapting them to the individual operating conditions.

Figure 13

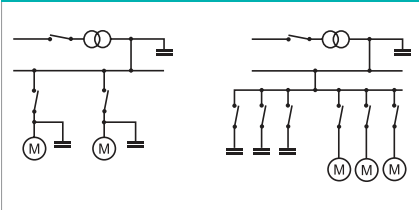

Determination of power in power factor correction equipment

The power of a power factor correction unit depends on the amount of reactive power, i.e. the kvar figure to be corrected for every hour. Usually a monthly power settlement is available. Since, large consumers of reactive power are granted 32,9 % ($\cos\varphi = 0,95$) of active power free of charge, excessive reactive power, which has to be paid for, can be calculated and corrected.

The monthly settlement contains the following information:

- A_v = active power-high tariff
- A_n = active power-low tariff
- W_v = reactive power-high tariff
- W_n = reactive power-low tariff
- P_{max} = peak loading-15 minutes

Necessary power of power correction equipment:

$$Q_c = P_{sr} (\operatorname{tg}\varphi_1 - \operatorname{tg}\varphi_2)$$

$$\cos\varphi_2 = \cos\varphi_k = 0,95$$

$$P_{sr} = \frac{A_v + A_n}{T}$$

$$\operatorname{tg}\varphi_1 = \frac{W_v + W_n}{A_v + A_n}$$

T = number of operating hours per month.

For values see tables 1 and 2.

Calculation example

Monthly balance of electrical power consumer:

- $A_v = 150.000 \text{ kWh}$
- $A_n = 100.000 \text{ kWh}$
- $W_v = 160.000 \text{ kvarh}$
- $W_n = 100.000 \text{ kvarh}$
- $T = 200 \text{ h}$

Necessary power of power correction equipment:

$$P_{sr} = \frac{A_v + A_n}{T} = \frac{150.000 + 100.000}{200}$$

$$P_{sr} = 1250 \text{ kW}$$

$$\operatorname{tg}\varphi_1 = \frac{W_v + W_n}{A_v + A_n}$$

$$\operatorname{tg}\varphi_1 = \frac{160.000 + 100.000}{150.000 + 100.000} = 1,04$$

$$Q_c = 1250 (1,040 - 0,329) = 890 \text{ kvar}$$

The same calculation can be illustrated by a diagram as in figure 13.

Figure 14

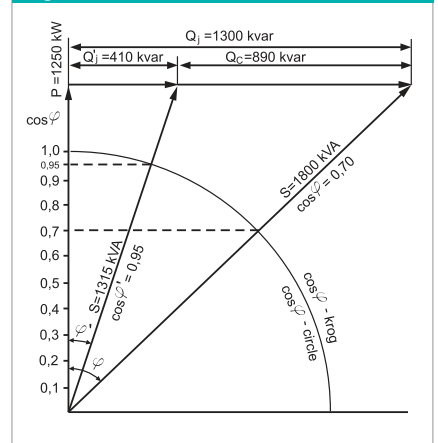

Table1

$\cos \varphi$	$\operatorname{tg} \varphi$	$\sin \varphi$	$\cos \varphi$	$\operatorname{tg} \varphi$	$\sin \varphi$
1	0	0	0,73	0,936	0,683
0,99	0,142	0,141	0,72	0,964	0,694
0,99	0,142	0,141	0,72	0,964	0,694
0,98	0,203	0,199	0,71	0,992	0,704
0,97	0,251	0,243	0,7	1,02	0,714
0,96	0,292	0,28	0,69	1,049	0,724
0,95	0,329	0,312	0,68	1,078	0,733
0,94	0,363	0,341	0,67	1,108	0,742
0,93	0,395	0,368	0,66	1,138	0,751
0,92	0,426	0,392	0,65	1,169	0,76
0,91	0,456	0,415	0,64	1,201	0,768
0,9	0,484	0,436	0,63	1,233	0,777
0,89	0,512	0,456	0,62	1,265	0,785
0,88	0,54	0,457	0,61	1,299	0,792
0,87	0,567	0,493	0,6	1,333	0,8
0,86	0,593	0,51	0,59	1,368	0,807
0,85	0,62	0,527	0,58	1,405	0,815
0,84	0,646	0,543	0,57	1,441	0,822
0,83	0,672	0,558	0,56	1,479	0,828
0,82	0,698	0,572	0,55	1,518	0,835
0,81	0,724	0,586	0,54	1,559	0,842
0,8	0,75	0,6	0,53	1,6	0,848
0,79	0,776	0,613	0,52	1,643	0,854
0,78	0,802	0,626	0,51	1,687	0,86
0,77	0,829	0,638	0,5	1,732	0,866
0,76	0,855	0,65			
0,75	0,882	0,661			
0,74	0,909	0,673			

Table2

Actual power factor $\cos \varphi_2$	Required power factor $\cos \varphi_2$												
	0,7	0,75	0,8	0,82	0,84	0,86	0,88	0,9	0,92	0,94	0,96	0,98	1
0,5	0,71	0,85	0,98	1,03	1,09	1,14	1,19	1,25	1,31	1,37	1,44	1,53	1,73
0,52	0,62	0,76	0,89	0,94	1	1,05	1,1	1,16	1,22	1,28	1,35	1,44	1,64
0,54	0,54	0,68	0,81	0,86	0,91	0,97	1,02	1,07	1,13	1,2	1,27	1,36	1,56
0,56	0,46	0,6	0,73	0,78	0,83	0,89	0,94	1	1,05	1,12	1,19	1,28	1,48
0,58	0,38	0,52	0,65	0,71	0,76	0,81	0,86	0,92	0,98	1,04	1,11	1,2	1,4
0,6	0,31	0,45	0,58	0,64	0,69	0,74	0,79	0,85	0,91	0,97	1,04	1,13	1,33
0,62	0,25	0,38	0,52	0,57	0,62	0,67	0,73	0,78	0,84	0,9	0,97	1,06	1,27
0,64	0,18	0,32	0,45	0,5	0,55	0,61	0,66	0,72	0,77	0,84	0,91	1	1,2
0,66	0,12	0,26	0,39	0,44	0,49	0,54	0,6	0,65	0,71	0,78	0,85	0,94	1,14
0,68	0,06	0,2	0,33	0,38	0,43	0,48	0,54	0,59	0,65	0,72	0,79	0,88	1,08
0,7		0,14	0,27	0,32	0,37	0,43	0,48	0,54	0,59	0,66	0,73	0,82	1,02
0,72		0,08	0,21	0,27	0,32	0,37	0,42	0,48	0,54	0,6	0,67	0,76	0,96
0,74		0,03	0,16	0,21	0,26	0,32	0,37	0,42	0,48	0,55	0,62	0,71	0,91
0,76			0,11	0,16	0,21	0,26	0,32	0,37	0,43	0,49	0,56	0,65	0,86
0,78			0,05	0,1	0,16	0,21	0,26	0,32	0,38	0,44	0,51	0,6	0,8
0,8				0,05	0,1	0,16	0,21	0,27	0,32	0,39	0,46	0,55	0,75
0,82					0,05	0,1	0,16	0,21	0,27	0,34	0,41	0,49	0,7
0,84						0,05	0,11	0,16	0,22	0,28	0,35	0,44	0,65
0,86							0,05	0,11	0,17	0,23	0,3	0,39	0,59
0,88								0,06	0,11	0,18	0,25	0,34	0,54
0,9									0,06	0,12	0,19	0,28	0,48
0,92										0,06	0,13	0,22	0,43
0,94											0,07	0,16	0,36

Production programme

Capacitors for electronics

- polyester foil
- polypropylene foil

Capacitors and filters for radio interference suppression

Motor running & motor starting capacitors

Lamp capacitors

Capacitors for power electronics

Power factor capacitors

Automatic power factor banks

Induction heating capacitors

Electronic regulators for power factor banks

Tools and production machines

W7



Iskra Kondenzatorji, d.d.

Vajdova ulica 71

SI-8333 Semič, Slovenia

Phone: +386 7 38 49 200

+386 7 38 49 275 - Sales Department

Fax: +386 7 30 67 110, 30 67 609

E-mail: iskra@iskra-capacitors.com

<http://www.iskra-capacitors.com>

