



MCE 940 SCADA

THE FAMILY OF EQUIPMENT DEDICATED FOR POWER UTILITIES

Energy Sector

MCE 940 SCADA

Description

The MCE 940 forms a powerful Supervisory, Control and Data Acquisition software (SCADA) intended specially for power distribution applications. The MCE 940 comprises functions of supervision, data collecting, control, data storage, analysis and graphical display by using single-line diagrams, interactive blocks and data charts. The MCE 940 is not limited in size of application and it can be used for any control level; from control of a single MV substation to control of the whole utility network. Due to its unique possibilities of expansion and customization it can be used for virtually any application.

Using Windows® based graphic screens the MCE 940 displays a real-time condition of substation, actual measurements and it helps the operator to make appropriate decisions in any given situation. Commands with integrated interlocking additionally prevent the operator from executing false commands.

The MCE 940 is a sub-module of the NEO 3000 substation control and protection system that shares the usual qualities of customization and open architecture options. These qualities offer satisfaction through possible further expansion and additional improvement throughout entire lifetime of the system.

Features

- Real-Time Process of Monitoring and Control
- Distributed Client/Server Architecture
- The MCE 940 is designed for both small stand-alone and networked applications
- Shares data with Oracle, SQL Server, Access and other SQL based relational databases
- Security system enables control of access to data and applications

Graphics

- Graphical display of Single-line diagrams
- Automatic topology coloring
- Zooming, panning and decluttering

Description

- Real-time display of the status and analog measurements of the power system
- Support for Geographic Information System (GIS)
- Commands with integrated interlocking
- Sequence control
- Alarming
- Trending
- Equipment statistics (number of breaker operations with maintenance alarming)
- Tags (elements with stored value after any reloading of the system)
- Events in high time-resolution (fault events, analog and digital)
- Energy metering
- Operational statistics of protection relays and circuit breakers
- Storing of historical data in the relational archive database
- Automatic print-out of events
- Lists of currently present and unacknowledged alarms
- List of inactive unacknowledged alarms
- Off-normal list
- Reports and print-outs at operators request
- User based security
- User control areas
- Maintenance mode for single points or entire RTUs (silencing alarms, command prevention)
- Status of LAN devices (servers, printers switches ...)
- Operator notes with integrated MS Word and MS Excel
- Simple integration of additional functions

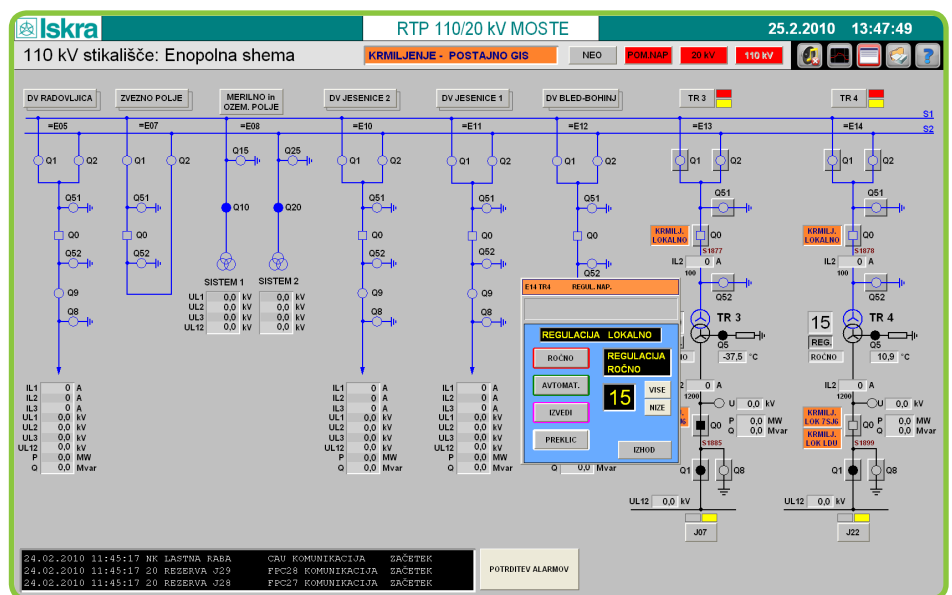

MCE 940 SCADA

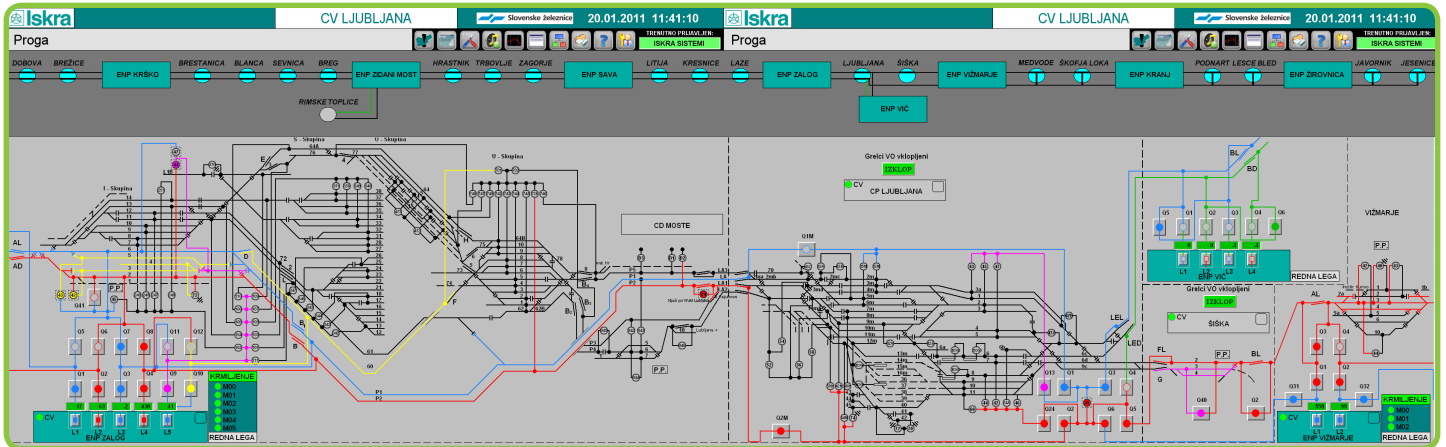

Control

MCE 940 includes the following control functions:

- Control switching elements
- Interlocking
- Simultaneous control prevention
- Control locking
- Control timeout
- Checking the success of the command execution
- Select Before Operate commands (SBO)
- Alarming of unexecuted commands
- Suppression of Alarms for Operator-Initiated Changes
- Manual data entry

Description

The MCE 940 incorporates a user friendly interface for process monitoring. Monitoring of the primary equipment condition is possible via process displays and special displays with unacknowledged, persistent and unacknowledged non-persistent alarms. In order to enable the operator to act quickly and properly in the event of a failure all irregularities are signaled by individual alarms. Operator can be guided to the source of alarm directly from single-line diagrams by marking specific areas of system, where the alarm occurred.

The alarm summary display combines unacknowledged and present alarms with the possibility of another list of non-present unacknowledged alarms. The alarms are displayed on the screen until they are acknowledged and until the signals state changes back to normal. The off-normal list is intended for the display of any abnormal states in the system.

The process display shows the system status. When an abnormal event occurs, the operator receives enough information about the event to make the correct decision.

Protocols

- IEC 61850
- IEC 60870-5-104
- 3rd party OPC
- Various protocols with the use of SCU810 communication gateway

Application

- Substations
- Distributions control centers
- Transmissions control centers
- Industrial/traffic power supplies control centers

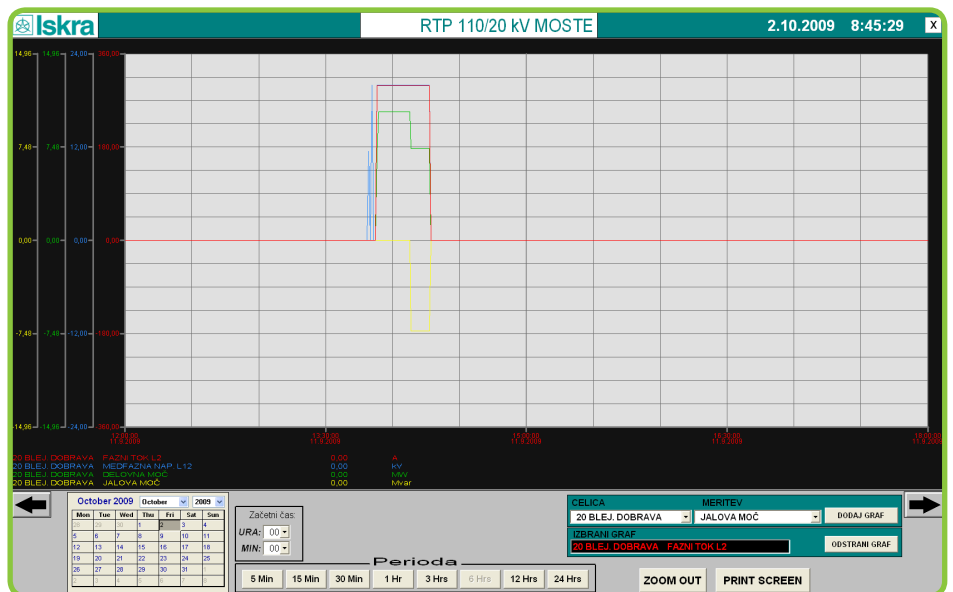

MCE 940 SCADA

Historical data

The reports program module is intended for displays and print-outs at the operator's request. The following displays and print-outs are built into the MCE 940 system: event list, alarm list, measurement list, energy metering reports, daily load report, daily load curve and more.

Event list is used for later analysis. Characteristic of this list is that you can create several filters for important system events arranged according to time (1 ms resolution).

The MCE 940 system supports two types of print-outs:

- Automatic print-out of all events
- Print-outs at operator's request

Historical data is stored in a standard SQL relational database, so it is easy to create additional custom-made reports using standard tools.

Historical data can be shared with other SQL-based relational databases such as Oracle, Access, SQL server, MySQL, etc.

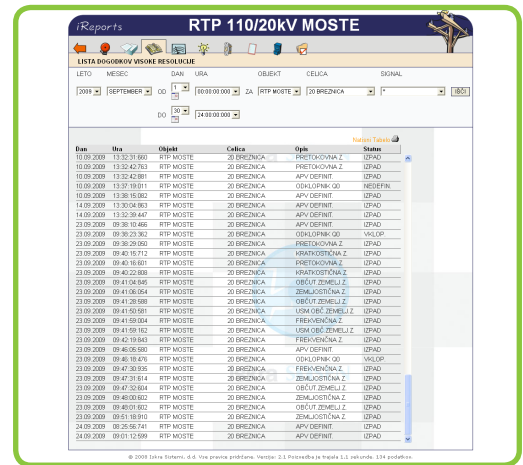
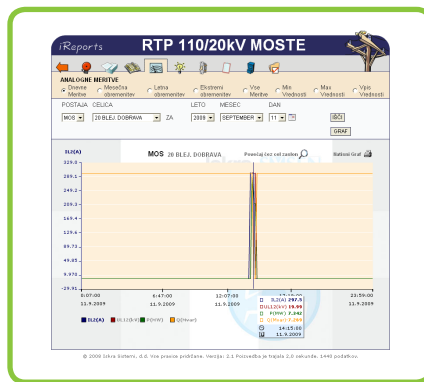
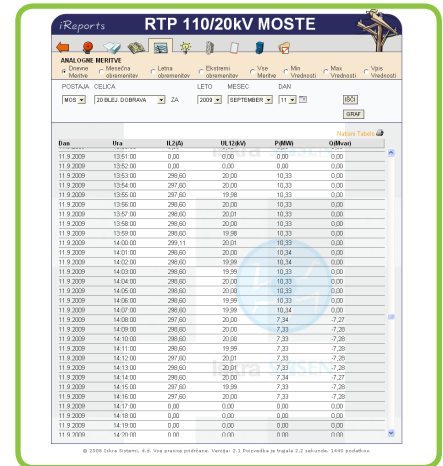

Platform

The MCE 940 software package runs on a Windows 7®, Windows® Server 2008 operating system environment. A full compatibility of the MCE 940 with those multi-task and multi-user operating systems grants long-term stability and carefree operation.

Industrial grade computers are chosen to provide dependable operation without interruptions. The minimum time between failures (MTBF) is declared to be 100,000 hours.

